

**MAX-5**



Let's grow together 

# MAX-5

Fit Actual Needs and Costs Effectively

## CPD15/18/20TV5

### Three-wheel Electric Forklift 1.5/1.8/2.0t

Dual-drive Performance

Perfect Balance between Dynamic and Working Space

EP EQUIPMENT CO.,LTD  
[www.ep-ep.com](http://www.ep-ep.com)

## Three-wheel Electric Forklift 1.5/1.8/2.0t CPD15/18/20TV5

Distinguishing mark				EP	EP	EP
1.1	Manufacturer			CPD15TV5	CPD18TV5	CPD20TV5
1.2	Model designation			Electrics	Electrics	Electrics
1.3	Drive unit			seated	seated	seated
1.4	Operator type			1500	1800	2000
1.5	rated capacity	Q	t	500	500	500
1.6	Load center distance	c	mm	397.5	397.5	397.5
1.8	Load distance, centre of drive axle to fork	x	mm	1468	1468	1468
1.9	Wheelbase	y	mm			
Weight						
2.1	Service weight (include battery)		kg	3000	3160	3380
2.2	Axle loading, laden driving wheels /steering wheels		kg	/	/	/
2.3	Axle loading, unladen driving wheels /steering wheels		kg	/	/	/
Types,Chassis						
3.1	Tyre type,driving wheels /steering wheels			solid rubber	solid rubber	solid rubber
3.2	Tyre size, driving wheels			18X7-8	18X7-8	200X50-10
3.3	Tyre size, steering wheels			15X4.5-8	15X4.5-8	15X4.5-8
3.5	Wheels, number driving/steering (x=drive wheels)		mm	2x/ 2	2x/ 2	2x/ 2
3.6	Tread, Driving wheels	b <sub>10</sub>	mm	902	902	902
3.7	Tread, Steering wheels	b <sub>11</sub>	mm	175	175	175
Dimensions						
4.1	Tilt of mast/fork carriage forward/backward	$\alpha / \beta$ (°)		6/6.5	6/6.5	6/6.5
4.2	Height, mast lowered	h <sub>1</sub>	mm	2060	2060	2060
4.3	Free lift (load backrest)	h <sub>2</sub>	mm	120	120	120
4.4	Lift height	h <sub>3</sub>	mm	3000	3000	3000
4.5	Height, mast extended	h <sub>4</sub>	mm	4011	4011	4011
4.7	Height of overhead guard (cabin)	h <sub>6</sub>	mm	2060	2060	2060
4.8	Seat height	h <sub>7</sub>	mm	920	920	920
4.12	Tow center of pin height	h <sub>10</sub>	mm	475	475	475
4.19	Overall length	l <sub>1</sub>	mm	2975	2975	2975
4.20	Length to face of forks	l <sub>2</sub>	mm	2055	2055	2055
4.21	Overall width	b <sub>1</sub> / b <sub>2</sub>	mm	1090	1090	1150
4.22	Fork dimensions	s/ e/ l	mm	40×100×920	40×100×920	40×100×920
4.23	Fork carriage class/type A, B			2A	2A	2A
4.24	Fork carriage width	b <sub>3</sub>	mm	1040	1040	1040
4.31	Ground clearance, laden, below mast	m <sub>1</sub>	mm	108	108	108
4.32	The minimum ground clearance of frame	m <sub>2</sub>	mm	78	78	78
4.34.1	Aisle width for pallets 1000 × 1200 crossways	Ast	mm	3400	3400	3400
4.34.2	Aisle width for pallets 800 × 1200 lengthways	Ast	mm	3526	3526	3526
4.35	Turning radius	Wa	mm	1680	1680	1680
Performance data						
5.1	Travel speed, laden/ unladen		km/ h	13/ 14	13/ 14	13/ 14
5.2	Lifting speed, laden/ unladen		m/ s	0.29/ 0.43	0.27/ 0.43	0.26/ 0.43
5.3	Lowering speed, laden/ unladen		m/ s	0.44/ 0.435	0.44/ 0.435	0.44/ 0.435
5.5	Drawbar pull, laden/unladen		N	/	/	/
5.6	Max. drawbar pull, laden/unladen (time)		N	/	/	/
5.7	Gradeability, laden/unladen		%	10.5/ 14.5	10.5/ 14.5	10.5/ 14.5
5.8	Max. gradeability, laden/unladen		%	/	/	/
5.10	Service brake type			Mechanical/ hydraulic	Mechanical/ hydraulic	Mechanical/ hydraulic
	park brake type			Mechanical/ hydraulic	Mechanical/ hydraulic	Mechanical/ hydraulic
Electric-engine						
6.1	Drive motor rating S2 60 min		kW	4.5x2	4.5x2	4.5x2
6.2	Lift motor rating at S3 15%		kW	11	11	11
6.3	The maximum allowed size battery		mm	/	/	/
6.4	Battery voltage/nominal capacity K5			48/400	48/400	48/500
6.5	Battery weight		kg	708	708	856
Addition data						
8.1	Type of drive unit			AC	AC	AC
10.5	Steering type			Mechanical/ hydraulic	Mechanical/ hydraulic	Mechanical/ hydraulic
10.7	Sound pressure level at the driver's ear		dB (A)	74	74	74

1.The parameters in the table are of the standard model. For more information, please contact us.  
2.The parameters are subject to change without notice.

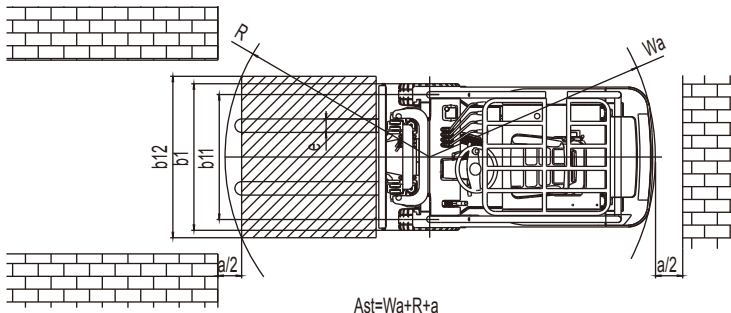
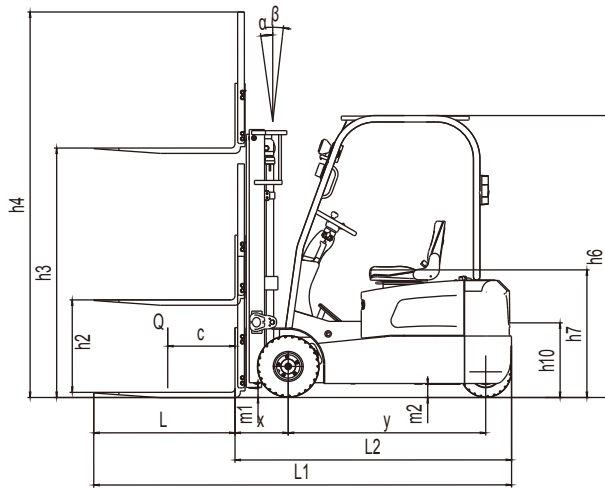

## Option

options	CPD15/18/20TV5
Fork length	•
Folding fork	•
high capacity battery	•
Import battery	•
Green solid tire	•
Cold storage (Apply to -20°C)	•
Fork weighing system	•
Customerized Overhead height	•
Mast lifting height	•
Attachment	•
LED Front working light	•
fire extinguisher	•
Auto-filling water system	•
Susepnsion seat	•
Warning light	•
Dual Mirrors	•
Rear working light	•
OPS	•
Speical backrest	•
battery trolley for lateral battery extraction	•
FAN	•
Special modification for Drive-in Racking	•



# Mast Option

## 1.5 1.8 2.0t TV5 series Standard mast types

Type	Model	Max. fork height			Overall height			Free lift		Front Overhang X			Tilt range		Capacity	
		h3 mm	Lowered h1 mm	Without backrest mm	With backrest h4 mm	Without backrest mm	With backrest h2 mm	1.5t mm	1.8t mm	2.0t mm	FWD α Deg	BWD β Deg	Load capacity at 500 mm			
													1.5t kg	1.8t kg		
Duplex ZT	2W200	2000	1490	2481	3011	120	120	397.5	397.5	397.5	6	6.5	1500	1800	2000	
	2W250	2500	1740	2981	3511	120	120	397.5	397.5	397.5	6	6.5	1500	1800	2000	
	2W270	2700	1840	3181	3711	120	120	397.5	397.5	397.5	6	6.5	1500	1800	2000	
	2W300	3000	1990	3481	4011	120	120	397.5	397.5	397.5	6	6.5	1500	1800	2000	
	2W330	3300	2140	3781	4311	120	120	397.5	397.5	397.5	6	6.5	1500	1800	2000	
	2W350	3500	2240	3981	4511	120	120	397.5	397.5	397.5	6	6.5	1500	1800	2000	
	2W360	3600	2290	4081	4611	120	120	397.5	397.5	397.5	6	6.5	1500	1800	2000	
	2W400	4000	2540	4481	5011	120	120	397.5	397.5	397.5	3	5	1400	1600	1800	
	2W425	4250	2665	4731	5261	120	120	397.5	397.5	397.5	3	5	1300	1500	1700	
	2W450	4500	2790	4981	5511	120	120	397.5	397.5	397.5	3	5	1250	1400	1600	
	2F250	2500	1773	2981	3511	1292	762	397.5	397.5	397.5	6	6.5	1500	1800	2000	
	2F270	2700	1873	3181	3711	1392	862	397.5	397.5	397.5	6	6.5	1500	1800	2000	
2F300	3000	2023	3481	4011	1542	1012	397.5	397.5	397.5	6	6.5	1500	1800	2000		
2F330	3300	2173	3781	4311	1692	1162	397.5	397.5	397.5	6	6.5	1500	1800	2000		
2F360	3600	2323	4081	4611	1842	1312	397.5	397.5	397.5	6	6.5	1500	1800	2000		
2F400	4000	2523	4481	5011	2042	1512	397.5	397.5	397.5	3	5	1400	1700	1900		
3F435	4350	1993	4831	5361	1512	982	397.5	397.5	397.5	3	5	1250	1450	1600		
3F450	4500	2043	4981	5511	1562	1032	397.5	397.5	397.5	3	5	1200	1350	1500		
3F480	4800	2143	5281	5811	1662	1132	397.5	397.5	397.5	3	5	1100	1250	1400		
3F500	5000	2208	5481	6011	1727	1197	397.5	397.5	397.5	3	5	1050	1150	1350		
3F550	5500	2378	5981	6511	1897	1367	397.5	397.5	397.5	3	5	/	1100	1250		
3F600	6000	2593	6481	7011	2112	1582	397.5	397.5	397.5	3	5	/	900	1150		

Note: With sideshifter minus 200Kg, with integral sideshifter minus 100Kg.

1. The parameters in the table are the standard model, for more information please contact us.

2. The parameters are subject to change without notice.

CPD15TV5 RATED CAPACITIES GRAPH

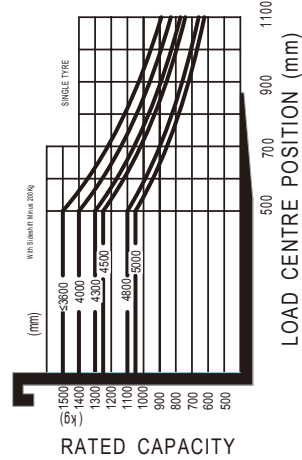

CPD18TV5 RATED CAPACITIES GRAPH

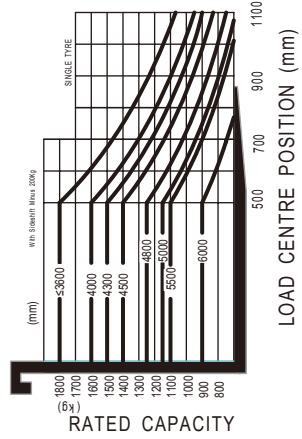

CPD20TV5 RATED CAPACITIES GRAPH

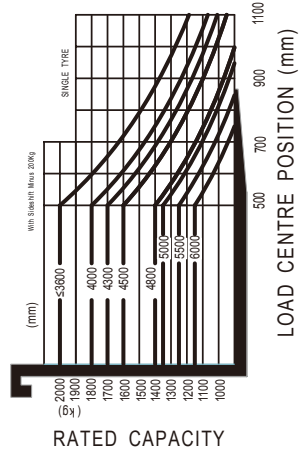

**MAX-5**