

VERTILINE

Liftable vertical bench with both retractable clamping bars

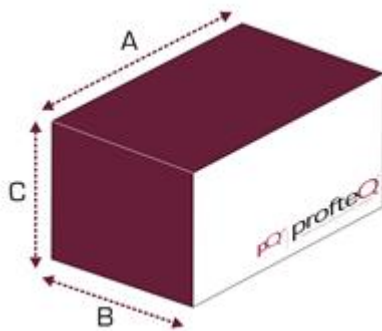

CE



A (mm)	B (mm)	C (mm)	Kg
4170	1200	2250	850

Technical specifications:

- The right moving beam stops on a disk brake, thus ensuring perfect parallelism with the left fixed beam and, consequently between the two frame uprights
- Rotation of both beams can rotate with exit of the finished frame both on the left and on the right
- Rollers made by galvanized steel anti-wear
- Frame support base with a lower swan neck to enable frames with a mechanical threshold or with a monobloc coextruded intrados to be machined
- Support base of the frame raised by 50 cm to insert easily the glazing clamping strip into the lower side
- Max frame width: 3.200 mm
- Max frame height: 2.500 mm

Working capacity

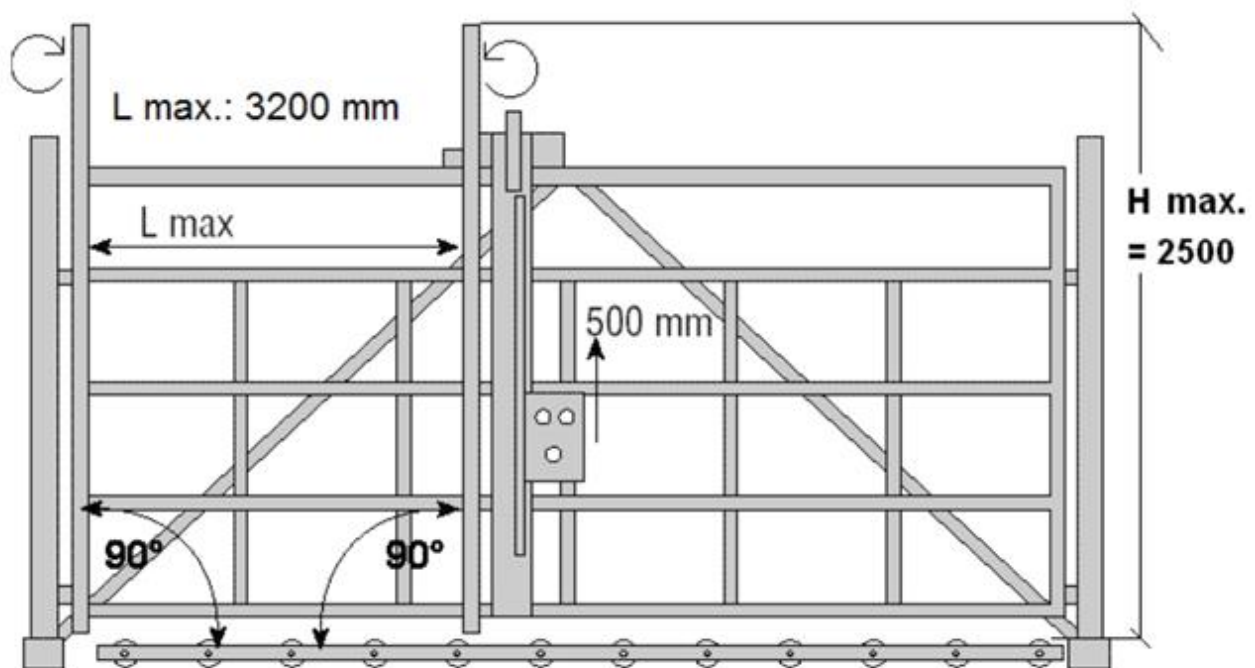

Optionals:

- Kit extension for pressing high windows (+500 mm)
- Extension lower roller conveyor
- VERTILINE ladder kit

Technical data:

- Air pressure: 6 - 8 bar
- Air consumption: 48 litre/ciclo