

COMPACT 2022/23



ZAVAGLI



ERLO

Drills / Units / CNC



FomIndustrie
Aluminium Working Machinery

RENNER
Kompressoren

del'air
COMPRESSORES

FRIULAIR®

FASANO
TOOLS

ZMM
BULGARIA

VESPA
CARBIDE



MEMODERIVA®
MÁQUINAS & EQUIPAMENTOS INDUSTRIAIS

www.memoderiva.pt

O seu parceiro de NEGÓCIOS



norte
a sul
e ilhas



ALTA PRESSÃO | página 3



AR COMPRIMIDO | página 10



MECÂNICA E ELEVAÇÃO | página 42



LUBRIFICAÇÃO | página 78



METALOMECÂNICA | página 93



ALUMÍNIO E PVC | página 115



MADEIRA | página 93



Rua das Flores, Carreira D'Água
Barosa 2400-016 LEIRIA Tif: (+351) 244 819 060

O digital é o futuro...



Estamos a trabalhar diariamente o nosso site para si. Mais informação de produtos, mais fichas técnicas, mais vídeos, e mais ferramentas para melhor identificar as necessidades dos clientes.

www.memoderiva.pt

Representamos as melhores marcas a pensar em si.



RENNER
Kompressoren



FomIndustrie
Aluminium Working Machinery





MÁQUINAS DE LAVAR A FRIO



LAVADORA ALTA PRESSÃO

VERTIGO 28 PLUS

160 BAR MAX - 510 L/H MAX

2800 W - 230 V - 4 HP

8 METROS MANGUEIRA

5 METROS CABO ALIMENTAÇÃO

6 DE BICOS DE LIMPEZA DIFERENTES

1 ESCOVA REDONDA PARA PAVIMENTO

1 ESCOVA ROTATIVA

1 TUBO PARA LIMPAR TUBOS

8.047.0020



499



MUITO COMPACTA
IDEAL PARA ÁREAS ATÉ 1.500M²
BAIXO RUÍDO
FÁCIL DESPEJO DO DEPÓSITO
FILTRO DE ÁGUA
RODAS ANTI MARCAÇÃO DE PAVIMENTO

MÁQUINA DE LAVAR PAVIMENTO

FREE EVO 50 B

COM CARREGADOR E BATERIA INCLUÍDOS

DISCO DE ESCOVA 500/800MM

TANQUE DE ASPIRAÇÃO 44 LT

MOTOR VACUO 400 W - 24 V

550 W DE POTENCIA NO MOTOR DA ESCOVA

8.527.0010



3.250



MÁQUINA DE LAVAR PAVIMENTO COM TRAÇÃO

FREE EVO 50 BT

COM CARREGADOR E BATERIA INCLUÍDOS

DISCO DE ESCOVA 500/800MM

TANQUE DE ASPIRAÇÃO 44 LT

MOTOR VACUO 400 W - 24 V

550 W DE POTENCIA NO MOTOR DA ESCOVA

8.527.0012



3.750



MÁQUINAS DE LAVAR A QUENTE



POWERWASH - GOLDBASE BASE

PWGB 160/15T	PWGB 200/15T	PWGB 200/21T	PWGB 250/15T
400 V - 160 BAR	400 V - 200 BAR	400 V - 200 BAR	400 V - 250 BAR
900 L/H - 15 L/MIN	900 L/H - 15 L/MIN	1260 L/H - 21 L/MIN	900 L/H - 15 L/MIN
4KW - 138 KG	5.5KW - 145 KG	7.5KW - 160 KG	7.5KW - 160 KG
1450 RPM / 5.5 HP	1450 RPM / 7.5 HP	1450 RPM / 10 HP	1450 RPM / 10 HP
DIESEL - 90°C	DIESEL - 90°C	DIESEL-90°C	DIESEL-90°C

PWGB 160/15T € 3.270

PWGB 200/15T € 3.490

PWGB 200/21T € 3.790

PWGB 250/15T € 3.790

BOMBA INTERPUMP



POWERWASH - SILVER BASE

PWSB 170/13T	PWSB 200/11T
400 V - 170 BAR	400 V - 200 BAR
780 L/H - 13 L/MIN	660 L/H - 11 L/MIN
4KW - 120 KG - 80°C	4KW - 120 KG - 80°C
1450 RPM / 5.5 HP	1450 RPM / 5.5 HP
QUEIMADOR A DIESEL COM MOTOR A 220 V	QUEIMADOR A DIESEL COM MOTOR A 220 V

BOMBA INTERPUMP

PWSB 170/13T € 2.590

PWSB 200/11T € 2.590



MÁQUINAS DE LAVAR

COM TOTAL STOP

POLO BASE
BOMBA INTERPUMP



PWP 160 / 15 T	PWP 200 / 21 T	PWP 250 / 15 T	PWP 200 / 15 T
400 V - 160 BAR	400 V - 200 BAR	400 V - 250 BAR	400 V - 200 BAR
900 L/H - 15 L/M	1260 L/H - 21 L/M	900 L/H - 15 L/M	900 L/H - 15 L/M
4 KW - 77 KG	7.5 KW - 92 KG	7.5 KW - 92 KG	5.5 KW - 92 KG
1450 RPM / 5.5 HP	1450 RPM / 10 HP	1450 RPM / 10 HP	1450 RPM / 7.5 HP

PWP 160 / 15 T € 2.120

PWP 200 / 15 T € 2.190

PWP 200 / 21 T € 2.540

PWP 250 / 15 T € 2.590



PWPP 250 / 15 BB	PWPP 200 / 15 BB	PWPP 200 / 15 DB
250 BAR	200 BAR	200 BAR
900 L/H - 15 L/M	900 L/H - 15 L/M	900 L/H - 15 L/M
9.5 KW - 70 KG	8 KW - 70 KG	8 KW - 70 KG
3400 RPM / 13 HP	3400 RPM / 11 HP	3400 RPM / 10 HP
MOTOR HONDA GASOLINA	MOTOR HONDA GASOLINA	MOTOR DIESEL YANMAR

BOMBA INTERPUMP

PWPP 250 / 15 BB € 2.770

PWPP 200 / 15 BB € 2.650



ARRANQUE AUTOMÁTICO

PWPP200/15DB € 3.750

QUALIDADE PREÇO - EXCELENTE
MOTOR HONDA A GASOLINA A 3000 RPM
MODO DE BY PASS EM STAND-BY



LANÇA CURVA COM BICO ROTATIVO - SCP + ROTOJET 255 BAR MAX

470 MM	470 MM	470 MM	470 MM	470 MM	470 MM
M22 X 1.5 M	M22 X 1.5 M	M22 X 1.5 M	M22 X 1.5	M22 X 1.5	M22 X 1.5
BICO 030	BICO 035	BICO 040	BICO 045	BICO 050	BICO 055
0202004400	0202004410	0202004420	0202004430	0202004440	0202004450
€ 39	€ 39	€ 41	€ 39	€ 41	€ 41

ACESSÓRIOS COMPATÍVEIS



PUNHO COMPLETO MECLINE



MV 925 G
G 3/8 M
30 LT/MIN
M22 X 1.5
310 BAR
4022105010

€ 25



MV 925
M22 X 1.5 M
30 LT/MIN
M22 X 1.5 F
310 BAR
4022105011

€ 26



MV 2009
M22 X 1.5 M
30 LT/MIN
M22 X 1.5 F
260 BAR
4021109006

€ 17



MV 2009
G 3/8 M
30 LT/MIN
M22 X 1.5
260 BAR
4021109013

€ 17



MV 925 SWTOP
M22 X 1.5 M
CARDAN GIRATÓRIO
M22 X 1.5 F
310 BAR
4012206002

€ 37



LANÇA SIMPLES



MV 162+AN 28
M22 X 1.5 M
577 MM
SEM BICO
280 BAR
4043900000

€ 16



SC+TPR255
M22 X 1.5 M
463 MM
BICO 030
250 BAR
4042100004

€ 35



SC+TPR255
M22 X 1.5 M
463 MM
BICO 035
250 BAR
4042100005

€ 35



SC+TPR255
M22 X 1.5 M
463 MM
BICO 045
250 BAR
4042100007

€ 35



SC+TPR255
M22 X 1.5 M
463 MM
BICO 04
200 BAR
473901130

€ 27

verde escuro



MV 9225 SW TOP
L35+ARF SHORT
M22 X 1.5 MACHO
30 L/MIN
300 BAR
160°C MAX
4022205006

€ 17



FILTRO ÁGUA
50 MESH
G 3/4 F
8105041

€ 8,5



TS 33
BICO 1.2 / 03
M22 X 1.5
6 MT - 18 MM
250 BAR

€ 95

0202903450



TS 14
BICO 1.3 / 035
M22 X 1.5
2 MT - 17 MM
140 BAR

€ 42

4058000009



G 1/4 M
1500 MM
250 BAR
1/4 NPT F

€ 14

0202000230

LANÇA DUPLA



LD+MV30M
22 X 1.5 M
4 1/4 F
565 MM
230 BAR

€ 29

0202004711

LD+MV30M
22 X 1.5 M
4 1/4 F
795 MM
230 BAR

€ 34

0202004721

ASPIRADORES INDUSTRIAIS



ASPIRADOR CUBA INOX

3 MOTORES
78 LITROS
220 V - 3600 W
E 2375 MS

€ 552

2 MOTORES
77 LITROS
220 V - 2400 W
E 2220 MS

€ 440

1 MOTORES
23 LITROS
220 V - 1400 W
E 2125 S

€ 220

EGECO



ASPIRADOR CUBA ABS

3 MOTORES
78 LITROS
220 V - 3600 W
E 2375 MP

€ 486

2 MOTORES
77 LITROS
220 V - 2400 W
E 2220 MP

€ 410



EGECO



ASPIRADOR COM EXTRACÇÃO

COM EXTRAÇÃO PARA LIXADEIRA
LIGAÇÃO ELÉTRICA E PNEUMÁTICA
76 LITROS - CUBA EM INOX
220 V - 2600 W - 2 MOTORES

E2EB250EAS € 799

EGECO



MÁQUINA DE LAVAR ESTOFOS

2 MOTORES
76 LITROS - CUBA EM INOX
220 V - 2600 W - 2 MOTORES

E 2250 LVS € 770



ASPIRADOR ALL BLACK

1 MOTORES
76 LITROS - CUBA EM INOX
220 V - 1700 W - 1 MOTOR
DEPÓSITO INDEPENDENTE COM RODAS

BL175EAS € 849

RENNER
Kompressoren



AR COMPRIMIDO



del'air
COMPRESSORES

made in italy

COMPRESSORES DE PARAFUSO



Compressores RENNER - Série RS e RS-PRO

Da carpintaria á robótica, passando pelos moldes, metalurgia ou alimentar, todas as industrias confiam nos compressores RENNER há dezenas de anos.

Não é de admirar, porque a fiabilidade, robustez e eficiência energética são o "Alpha e Omega" na tecnologia de ar comprimido. A Série RS-PRO é direcionada para requisitos de ar comprimido médio em uso industrial.

Os compressores de parafuso modificados, injetados a óleo com accionamento por correia impressionam, com grandes quantidades geradas de fluxo de ar e um design compacto.

Diversos modelos, para ir de encontro ao que procura e ter a solução ideal para a sua linha de ar comprimido.

Devido às dimensões compactas, áreas de manutenção de fácil acesso, controladores claramente dispostos e operação com baixo ruído e baixa vibração, os compressores de parafuso são particularmente fáceis de usar e de manutenção.



RENNER



RS PRO 5.5

5.5 KW DE POTÊNCIA - 7.5 HP
SAÍDA 1/2 POLEGADA - 61 dB
CONTADOR DE HORAS.
MANÓMETROS DE PRESSÃO E TEMPERATURA
BOTONEIRA START STOP
540 X 553 X 1014 - 172 KG

€ 5.670

Modell	Liefermenge m ³ /min ¹¹			
	7,5 bar	10 bar	13 bar	15 bar
RS-PRO 5,5	0,91	0,78	0,61	0,51
RS-PRO 7,5	1,25	1,09	0,86	0,79
RS-PRO 11,0	1,61	1,56	1,29	1,11

RENNER



RS PRO 7.5



7.5 KW DE POTÊNCIA - 10 HP
SAÍDA 1/2 POLEGADA - 61 dB
CONTADOR DE HORAS.
MANÓMETROS DE PRESSÃO E TEMPERATURA
BOTONEIRA START STOP
540 X 553 X 1014 - 198 KG

€ 5.920

Modell	Liefermenge m ³ /min ¹¹			
	7,5 bar	10 bar	13 bar	15 bar
RS-PRO 5,5	0,91	0,78	0,61	0,51
RS-PRO 7,5	1,25	1,09	0,86	0,79
RS-PRO 11,0	1,61	1,56	1,29	1,11



AR COMPRIMIDO

COMPRESSORES DE PARAFUSO



11 KW DE POTÊNCIA - 15 HP
 SAÍDA 3/4 POLEGADA - 69 dB
 CONTADOR DE HORAS.
 MANÓMETROS DE PRESSÃO E TEMPERATURA
 BOTONEIRA START STOP
 1078 X 684 X 1131 - 337 KG

RS PRO 11.0



Modell	Liefermenge m ³ /min ⁽¹⁾			
	7,5 bar	10 bar	13 bar	15 bar
RS-PRO 5,5	0,91	0,78	0,61	0,51
RS-PRO 7,5	1,25	1,09	0,86	0,79
RS-PRO 11,0	1,61	1,56	1,29	1,11

€ 6.930

RENNER

15 KW DE POTÊNCIA - 20 HP
 SAÍDA 3/4 POLEGADA - 72 dB
 CONTADOR DE HORAS.
 MANÓMETROS DE PRESSÃO E TEMPERATURA
 BOTONEIRA START STOP
 1078 X 684 X 1131 - 389 KG

RS PRO 15.0



Modell	Liefermenge m ³ /min ⁽¹⁾			
	7,5 bar	10 bar	13 bar	15 bar
RS-PRO 15,0	2,67	2,31	1,86	1,69
RS-PRO 18,5	2,82	2,45	1,96	1,78

€ 8.430

RENNER

18.5 KW DE POTÊNCIA - 25 HP
 SAÍDA 1 POLEGADA - 74 dB
 CONTADOR DE HORAS.
 MANÓMETROS DE PRESSÃO E TEMPERATURA
 BOTONEIRA START STOP
 1160 X 747 X 1270 - 466 KG

RS PRO 2-18.5



Model	Free air delivery ⁽¹⁾								Motor power		Compressed air outlet
	7.5 bar		10 bar		13 bar		15 bar		kW	HP	inch
	m ³ /min	cfm	m ³ /min	cfm	m ³ /min	cfm	m ³ /min	cfm			
RS-PRO 2-18.5	3.81	129	2.91	103	2.40	85	2.06	73	18.5	25.0	G1
RS-PRO 22.0	3.93	139	3.44	121	2.73	96	2.31	89	22.0	29.5	G1

€ 9.860

COMPRESSORES DE PARAFUSO



RS PRO 22,0

22 KW DE POTÊNCIA - 30 HP
SAÍDA 1 1/4 POLEGADA - 71 dB
CONTADOR DE HORAS.
MANÓMETROS DE PRESSÃO E TEMPERATURA
BOTONEIRA START STOP
1287 X 799 X 1296 - 547 KG

€ 10.990

Model	Free air delivery ¹⁾							
	7.5 bar		10 bar		13 bar		15 bar	
	m ³ /min	cfm	m ³ /min	cfm	m ³ /min	cfm	m ³ /min	cfm
RS 18.5	2.91	103	2.62	93	2.20	78	1.89	67
RS 22.0	3.46	122	3.10	109	2.66	94	2.31	82
RS 1-30.0	4.38	155	4.01	142	3.52	124	3.02	107

RENNER



RS PRO 30,0

30 KW DE POTÊNCIA - 40 HP
SAÍDA 1 1/4 POLEGADA - 72 dB
CONTADOR DE HORAS.
MANÓMETROS DE PRESSÃO E TEMPERATURA
BOTONEIRA START STOP
1287 X 799 X 1296 - 609 KG

€ 12.500

Model	Free air delivery ¹⁾							
	7.5 bar		10 bar		13 bar		15 bar	
	m ³ /min	cfm	m ³ /min	cfm	m ³ /min	cfm	m ³ /min	cfm
RS 18.5	2.91	103	2.62	93	2.20	78	1.89	67
RS 22.0	3.46	122	3.10	109	2.66	94	2.31	82
RS 1-30.0	4.38	155	4.01	142	3.52	124	3.02	107

RENNER



RS PRO 37,0

37 KW DE POTÊNCIA - 50 HP
SAÍDA 1 1/4 POLEGADA - 77 dB
CONTADOR DE HORAS.
MANÓMETROS DE PRESSÃO E TEMPERATURA
BOTONEIRA START STOP
1240 X 792 X 1372 - 605 KG

€ 15.500

Model	Free air delivery ¹⁾								Motor power	
	7.5 bar		10 bar		13 bar		15 bar		kW	HP
	m ³ /min	cfm	m ³ /min	cfm	m ³ /min	cfm	m ³ /min	cfm		
RS-PRO 37.0	5.54	196	5.23	185	4.39	155	4.08	144	37.0	49.5
RS-PRO 2-37.0	6.36	225	5.58	197	4.66	165	4.10	145	37.0	49.5
RS-PRO 45.0	7.70	272	6.92	244	5.71	202	4.99	176	45.0	60.5
RS-PRO 55.0	9.02	319	7.94	280	6.93	245	6.09	215	55.0	74.0



AR COMPRIMIDO



COMPRESSORES DE PARAFUSO



45 KW DE POTÊNCIA - 60 HP
 SAÍDA 1 1/2 POLEGADA - 77 dB
 CONTADOR DE HORAS.
 MANÔMETROS DE PRESSÃO E TEMPERATURA
 1485 X 880 X 1760 - 939 KG

RS PRO 45.0



€ 18.990

Model	Free air delivery ⁽¹⁾							
	7.5 bar		10 bar		13 bar		15 bar	
	m ³ /min	cfm	m ³ /min	cfm	m ³ /min	cfm	m ³ /min	cfm
RS-PRO 2-30.0	5.22	184	4.61	163	3.59	127	3.29	117
RS-PRO 2-37.0	6.36	225	5.58	197	4.66	165	4.10	145
RS-PRO 45.0	7.70	272	6.92	244	5.71	202	4.99	176
RS-PRO 55.0	9.02	319	7.94	280	6.93	245	6.09	215



55 KW DE POTÊNCIA - 74 HP
 CONTADOR DE HORAS.
 MANÔMETROS DE PRESSÃO E TEMPERATURA
 SAÍDA 1 1/2 POLEGADA - 79 dB
 1485 X 880 X 1760 - 1064 KG

RS PRO 55.0



€ 20.950

Model	Free air delivery ⁽¹⁾							
	7.5 bar		10 bar		13 bar		15 bar	
	m ³ /min	cfm	m ³ /min	cfm	m ³ /min	cfm	m ³ /min	cfm
RS-PRO 2-30.0	5.22	184	4.61	163	3.59	127	3.29	117
RS-PRO 2-37.0	6.36	225	5.58	197	4.66	165	4.10	145
RS-PRO 45.0	7.70	272	6.92	244	5.71	202	4.99	176
RS-PRO 55.0	9.02	319	7.94	280	6.93	245	6.09	215



3 SISTEMAS OPCIONAIS DE CONTROLADORES RENNER



RENNERlogic - controle padrão



RENNERtronic Touch - fácil de usar.
Controle básico



RENNERtronic Plus Touch - funções
estendidas

COMPRESSORES DE PARAFUSO



Compressores RENNER - Série RSF com VARIADOR DE FREQUÊNCIA

Da carpintaria à robótica, passando pelos moldes, metalurgia ou alimentar, todas as indústrias confiam nos compressores RENNER há dezenas de anos.

A fiabilidade RENNER agregada a um sistema inovador com variador de frequência, oferece-lhe um compressor com um comportamento inteligente, que trabalha à medida das suas necessidades.

Este sistema inovador permite-lhe economizar mais de 35 % de energia, não só no arranque progressivo da máquina mas durante todo o período de trabalho do compressor, garantindo uma maior estabilidade e segurança do motor.

A Série RSF é direcionada para requisitos elevados de ar comprimido no uso industrial.

Os compressores de parafuso modificados, injetados a óleo com accionamento por correia impressionam, com grandes quantidades geradas de fluxo de ar e um design compacto.

Devido às dimensões compactas, áreas de manutenção de fácil acesso, controladores intuitivos e operação de baixo ruído e baixa vibração, os compressores de parafuso têm um desempenho brutal e de fácil manutenção.

Alem de toda uma máquina perfeita, ainda tem a capacidade fazer de MASTER ou de bloco principal na ligação em série a outros compressores RENNER e fazer a gestão inteligente de toda a linha.

RENNER



RSF PRO 7.5



€ **9.080**

7.5 KW DE POTÊNCIA - 10 HP
SAÍDA 1/2 POLEGADA - 62 dB
CONTADOR DE HORAS.
MANÓMETROS DE PRESSÃO E TEMPERATURA
COM VARIADOR DE FREQUÊNCIA
824 X 553 X 1014- 237 KG

Model	Free air delivery (RTS) ¹⁰⁰				Free air delivery ¹⁰				Motor power	Compressed air outlet					
	min.	max. at 6 bar	max. at 8 bar	max. at 10 bar	13 bar		15 bar								
	m ³ /min	cfm	m ³ /min	cfm	m ³ /min	cfm	m ³ /min	cfm	kW	HP	inch				
RSF-PRO 5.5	8.27	6.5	8.98	35	8.98	35	8.78	28	8.31-8.62	11.32	0.26-0.31	9-10	5.5	7.5	G1/2
RSF-PRO 7.5	8.33	12	1.37	48	1.24	44	1.08	38	8.43-8.88	15.00	0.40-0.78	14-18	7.5	10.0	G1/2
RSF-PRO 11.0	8.82	15	1.64	58	1.68	57	1.56	55	8.65-1.28	23-46	0.58-1.11	20-28	11.0	15.0	G1/2
RSF-PRO 2-11.0	8.54	18	2.04	73	1.82	64	1.61	57	8.75-1.38	25-46	0.67-1.12	24-40	11.0	15.0	G1/2
RSF-PRO 15.0	8.70	25	2.74	91	2.57	91	2.31	83	8.93-1.88	33-60	0.84-1.68	30-60	15.0	20.0	G1/2

RENNER



RSF PRO 11.0

€ **10.990**

11 KW DE POTÊNCIA - 15 HP
SAÍDA 3/4 POLEGADA - 69 dB
CONTADOR DE HORAS.
MANÓMETROS DE PRESSÃO E TEMPERATURA
COM VARIADOR DE FREQUÊNCIA
1078 X 684 X 1131 - 373 KG

Model	Free air delivery (RTS) ¹⁰⁰				Free air delivery ¹⁰				Motor power	Compressed air outlet					
	min.	max. at 6 bar	max. at 8 bar	max. at 10 bar	13 bar		15 bar								
	m ³ /min	cfm	m ³ /min	cfm	m ³ /min	cfm	m ³ /min	cfm	kW	HP	inch				
RSF-PRO 5.5	8.27	6.5	8.98	35	8.98	35	8.78	28	8.31-8.62	11.32	0.26-0.31	9-10	5.5	7.5	G1/2
RSF-PRO 7.5	8.33	12	1.37	48	1.24	44	1.08	38	8.43-8.88	15.00	0.40-0.78	14-18	7.5	10.0	G1/2
RSF-PRO 11.0	8.82	15	1.64	58	1.68	57	1.56	55	8.65-1.28	23-46	0.58-1.11	20-28	11.0	15.0	G1/2
RSF-PRO 2-11.0	8.54	18	2.04	73	1.82	64	1.61	57	8.75-1.38	25-46	0.67-1.12	24-40	11.0	15.0	G1/2
RSF-PRO 15.0	8.70	25	2.74	91	2.57	91	2.31	83	8.93-1.88	33-60	0.84-1.68	30-60	15.0	20.0	G1/2



COMPRESSORES DE PARAFUSO



15 KW DE POTÊNCIA - 20 HP
SAÍDA 3/4 POLEGADA - 71 dB
CONTADOR DE HORAS.
MANÔMETROS DE PRESSÃO E TEMPERATURA
COM VARIADOR DE FREQUÊNCIA
1078 X 684 X 1131 - 389 KG

RSF PRO 15.0



€ 13.260

Model	Free air delivery (RTD) ¹⁰⁰						Free air delivery ¹¹				Motor power	Compressed air outlet			
	min.		max. at 6 bar		max. at 8 bar		13 bar		15 bar						
	m³/min	cfm	m³/min	cfm	m³/min	cfm	m³/min	cfm	m³/min	cfm					
RSF-PRO 5.5	0.27	9.5	0.98	35	0.98	35	0.78	28	0.20-0.60	11.00	0.26-0.51	9.18	5.5	7.5	G1/2
RSF-PRO 7.5	0.33	12	1.37	48	1.24	44	1.08	39	0.43-0.86	15.00	0.40-0.75	14.28	7.5	10.0	G1/2
RSF-PRO 11.0	0.50	18	1.64	58	1.58	57	1.56	55	0.65-1.30	21.46	0.56-1.11	20.28	11.0	15.0	G1/2
RSF-PRO 2-11.0	0.53	19	2.04	73	1.82	64	1.81	65	0.75-1.38	25.46	0.67-1.12	24.48	11.0	15.0	G1/2
RSF-PRO 15.0	0.71	25	2.74	97	2.52	91	2.31	83	0.93-1.86	33.46	0.84-1.68	30.68	15.0	20.0	G1/2

RENNER

18.5 KW DE POTÊNCIA - 25 HP
SAÍDA 1 POLEGADA - 71 dB
CONTADOR DE HORAS.
MANÔMETROS DE PRESSÃO E TEMPERATURA
COM VARIADOR DE FREQUÊNCIA
1243 X 747 x 1270 - 524 KG

RSF PRO 2-18.5



€ 15.500

Model	Free air delivery (RTD) ¹⁰⁰						Free air delivery ¹¹				Motor power	Compressed air outlet			
	min.		max. at 6 bar		max. at 8 bar		13 bar		15 bar						
	m³/min	cfm	m³/min	cfm	m³/min	cfm	m³/min	cfm	m³/min	cfm					
RSF-PRO 18.5	0.86	31	2.81	100	2.64	93	2.45	87	0.98-1.96	35.40	0.89-1.78	31.43	18.5	25.0	G1
RSF-PRO 2-18.5	1.26	45	3.86	141	3.55	125	3.26	115	1.25-2.57	44.41	1.16-2.21	41.48	18.5	25.0	G1
RSF-PRO 22.0	1.33	47	4.48	155	3.86	141	3.54	125	1.24-2.93	44.18	1.18-2.48	42.95	22.0	29.5	G1
RSF-PRO 30.0	2.05	73	5.40	190	5.09	180	4.51	159	1.92-3.86	68.13	1.84-3.54	65.12	30.0	40.0	G1 1/2
RSF-PRO 2-30.0	1.88	66	5.48	200	5.20	185	4.61	164	1.91-3.94	70.12	1.85-3.26	66.15	30.0	40.0	G1 1/2
RSF-PRO 37.0	1.88	70	6.71	244	5.46	194	5.20	187	1.94-4.08	69.18	1.89-4.18	67.10	37.0	49.5	G1 1/2



RENNER
Kompressoren



RENNER
Kompressoren





COMPRESSORES DE PARAFUSO



RSF PRO 22,0



22 KW DE POTÊNCIA - 30 HP
SAÍDA 1 1/4 POLEGADA - 71 dB
1287 X 799 X 1296 - 588 KG
COM VARIADOR DE FREQUÊNCIA

€ 17.400

Model	Free air delivery (RfA)***								Free air delivery**				Motor power		Compressed air outlet
	6 bar		8 bar		10 bar		13 bar		15 bar		kW	HP	inch		
	m³/min	cfm	m³/min	cfm	m³/min	cfm	m³/min	cfm	m³/min	cfm					
RSF-PRO 18.5	0.86	31	2.82	100	2.64	93	2.45	87	0.98-1.96	35-69	0.89-1.78	31-63	18.5	25.2	G1/2
RSF-PRO 2-18.5	1.26	45	3.96	141	3.55	125	3.26	115	1.25-2.57	44-81	1.16-2.23	41-68	18.5	25.2	G1
RSF-PRO 22.0	1.33	47	4.00	155	3.89	141	3.54	125	1.24-2.90	44-100	1.16-2.48	42-66	22.0	29.5	G1
RSF-PRO 30.0	2.05	73	5.80	198	5.29	180	6.51	159	1.92-3.96	68-138	1.84-3.54	65-125	30.0	40.2	G1 1/2
RSF-PRO 2-30.0	1.68	59	5.08	200	5.23	185	6.61	162	1.91-3.18	26-127	0.85-1.28	30-115	30.0	40.2	G1 1/2
RSF-PRO 33.0	1.98	70	5.71	204	5.46	194	6.30	187	1.94-4.08	69-162	1.89-4.16	67-167	33.0	49.5	G1 1/2



RENNER



RSF PRO 30

30 KW DE POTÊNCIA - 40 HP
SAÍDA 1 1/4 POLEGADA - 72 dB
1388 X 792 X 1377 - 667 KG
COM VARIADOR DE FREQUÊNCIA

€ 19.300

Model	Free air delivery (RfA)***								Free air delivery**				Motor power		Compressed air outlet
	6 bar		8 bar		10 bar		13 bar		15 bar		kW	HP	inch		
	m³/min	cfm	m³/min	cfm	m³/min	cfm	m³/min	cfm	m³/min	cfm					
RSF-PRO 18.5	0.86	31	2.82	100	2.64	93	2.45	87	0.98-1.96	35-69	0.89-1.78	31-63	18.5	25.2	G1/2
RSF-PRO 2-18.5	1.26	45	3.96	141	3.55	125	3.26	115	1.25-2.57	44-81	1.16-2.23	41-68	18.5	25.2	G1
RSF-PRO 22.0	1.33	47	4.00	155	3.89	141	3.54	125	1.24-2.90	44-100	1.16-2.48	42-66	22.0	29.5	G1
RSF-PRO 30.0	2.05	73	5.80	198	5.29	180	6.51	159	1.92-3.96	68-138	1.84-3.54	65-125	30.0	40.2	G1 1/2
RSF-PRO 2-30.0	1.68	59	5.08	200	5.23	185	6.61	162	1.91-3.18	26-127	0.85-1.28	30-115	30.0	40.2	G1 1/2
RSF-PRO 33.0	1.98	70	5.71	204	5.46	194	6.30	187	1.94-4.08	69-162	1.89-4.16	67-167	33.0	49.5	G1 1/2

RENNER



RSF PRO 37

37 KW DE POTÊNCIA - 50 HP
SAÍDA 1 1/4 POLEGADA - 72 dB
1305 X 830 X 1640 - 762 KG
COM VARIADOR DE FREQUÊNCIA

€ 20.990

Model	Free air delivery (RfA)***								Free air delivery**				Motor power		Compressed air outlet
	6 bar		8 bar		10 bar		13 bar		15 bar		kW	HP	inch		
	m³/min	cfm	m³/min	cfm	m³/min	cfm	m³/min	cfm	m³/min	cfm					
RSF-PRO 18.5	0.86	31	2.82	100	2.64	93	2.45	87	0.98-1.96	35-69	0.89-1.78	31-63	18.5	25.2	G1/2
RSF-PRO 2-18.5	1.26	45	3.96	141	3.55	125	3.26	115	1.25-2.57	44-81	1.16-2.23	41-68	18.5	25.2	G1
RSF-PRO 22.0	1.33	47	4.00	155	3.89	141	3.54	125	1.24-2.90	44-100	1.16-2.48	42-66	22.0	29.5	G1
RSF-PRO 30.0	2.05	73	5.80	198	5.29	180	6.51	159	1.92-3.96	68-138	1.84-3.54	65-125	30.0	40.2	G1 1/2
RSF-PRO 2-30.0	1.68	59	5.08	200	5.23	185	6.61	162	1.91-3.18	26-127	0.85-1.28	30-115	30.0	40.2	G1 1/2
RSF-PRO 33.0	1.98	70	5.71	204	5.46	194	6.30	187	1.94-4.08	69-162	1.89-4.16	67-167	33.0	49.5	G1 1/2



AR COMPRIMIDO



COMPRESSORES DE PARAFUSO



45 KW DE POTÊNCIA - 60.5 HP
 SAÍDA 1 1/2 POLEGADA - 74 dB
 1680 X 880 X 1760 - 1120 KG
 COM VARIADOR DE FREQUÊNCIA

RSF PRO 45.0



€ 28.630

Model	Free air delivery (RTflex) ¹⁾								Free air delivery ²⁾				Motor power		Compressed air outlet		
	min.		max. at 6 bar		max. at 8 bar		max. at 10 bar		13 bar		15 bar		kW	HP			
	m ³ /min	cfm	m ³ /min	cfm	m ³ /min	cfm	m ³ /min	cfm	m ³ /min	cfm	m ³ /min	cfm					
RSF PRO 30.0	2.05	73	5.08	180	5.08	180	4.70	159	1.52	53.0	88	313	1.84	65.4	63	42.0	57%
RSF PRO 33.0	3.68	130	5.68	200	5.23	185	4.69	163	1.07	37.9	30	107	8.95	30.9	30.8	48.0	57%
RSF PRO 37.0	5.08	179	5.77	204	5.48	194	5.38	187	1.94	68.0	69	242	1.88	67.4	67	48.5	57%
RSF PRO 37.0	2.18	78	8.38	296	6.04	214	5.87	207	1.33	46.6	47	163	1.11	41.0	38	44.4	57%
RSF PRO 45.0	2.58	91	8.54	302	7.78	275	7.02	248	1.68	59.7	60	211	1.45	49.8	51	47.5	57%
RSF PRO 55.0	3.08	108	8.34	290	8.95	316	8.19	289	2.01	70.9	71	249	1.73	60.8	61	53.8	62%

RENNER

55 KW DE POTÊNCIA - 75 HP
 SAÍDA 1 1/2 POLEGADA - 74 dB
 1680 X 880 X 1760 - 1198 KG
 COM VARIADOR DE FREQUÊNCIA

RSF PRO 55.0



€ 32.100

Model	Free air delivery (RTflex) ¹⁾								Free air delivery ²⁾				Motor power		Compressed air outlet		
	min.		max. at 6 bar		max. at 8 bar		max. at 10 bar		13 bar		15 bar		kW	HP			
	m ³ /min	cfm	m ³ /min	cfm	m ³ /min	cfm	m ³ /min	cfm	m ³ /min	cfm	m ³ /min	cfm					
RSF PRO 30.0	2.05	73	5.08	180	5.08	180	4.70	159	1.52	53.0	88	313	1.84	65.4	63	42.0	57%
RSF PRO 33.0	3.68	130	5.68	200	5.23	185	4.69	163	1.07	37.9	30	107	8.95	30.9	30.8	48.0	57%
RSF PRO 37.0	5.08	179	5.77	204	5.48	194	5.38	187	1.94	68.0	69	242	1.88	67.4	67	48.5	57%
RSF PRO 37.0	2.18	78	8.38	296	6.04	214	5.87	207	1.33	46.6	47	163	1.11	41.0	38	44.4	57%
RSF PRO 45.0	2.58	91	8.54	302	7.78	275	7.02	248	1.68	59.7	60	211	1.45	49.8	51	47.5	57%
RSF PRO 55.0	3.08	108	8.34	290	8.95	316	8.19	289	2.01	70.9	71	249	1.73	60.8	61	53.8	62%

RENNER

75 KW DE POTÊNCIA - 100 HP
 SAÍDA 2 POLEGADAS - 74 dB
 1754 X 1104 X 1697 - 1440 KG
 COM VARIADOR DE FREQUÊNCIA

RSF 75.0



€ 36.160

Model	Free air delivery (RTflex) ¹⁾								Free air delivery ²⁾				Motor power		Compressed air outlet		
	min.		max. at 6 bar		max. at 8 bar		max. at 10 bar		13 bar		15 bar		kW	HP			
	m ³ /min	cfm	m ³ /min	cfm	m ³ /min	cfm	m ³ /min	cfm	m ³ /min	cfm	m ³ /min	cfm					
RSF 55.0	3.38	116	10.20	360	9.21	325	8.23	291	2.64	93.0	93	330	2.23	76.2	82	53.0	62%
RSF 75	4.19	148	12.81	452	11.93	409	10.25	364	3.64	129	129	459	2.23	76.2	75	100	62%



COMPRESSOR + DEPÓSITO + SECADOR



Model	Free air delivery ⁽¹⁾				Motor power	
	7.5 bar		10 bar		kW	HP
	m ³ /min	cfm	m ³ /min	cfm		
RSDK-PRO-ECN 3.0	0.54	19	0.41	15	3.0	4.0
RSDK-PRO-ECN 4.0	0.69	24	0.55	20	4.0	5.5
RSDK-PRO-ECN 5.5	0.91	32	0.78	28	5.5	7.5
RSDK-PRO-ECN 7.5	1.25	44	1.09	38	7.5	10.0
RSDK-PRO-ECN 11.0	1.61	57	1.56	55	11.0	15.0

RSDK PRO ECN 5.5

€ 8.300

5.5 KW DE POTÊNCIA - 7.5 HP
SAÍDA 1/2 POLEGADA - 63 dB
1490 X 554 X 1609 - 325 KG
DEPÓSITO DE 270 LTS
COM SECADOR INCORPORADO



RENNER



Model	Free air delivery ⁽¹⁾				Motor power	
	7.5 bar		10 bar		kW	HP
	m ³ /min	cfm	m ³ /min	cfm		
RSDK-PRO-ECN 3.0	0.54	19	0.41	15	3.0	4.0
RSDK-PRO-ECN 4.0	0.69	24	0.55	20	4.0	5.5
RSDK-PRO-ECN 5.5	0.91	32	0.78	28	5.5	7.5
RSDK-PRO-ECN 7.5	1.25	44	1.09	38	7.5	10.0
RSDK-PRO-ECN 11.0	1.61	57	1.56	55	11.0	15.0

RSDK PRO ECN 7.5

€ 8.800

7.5 KW DE POTÊNCIA - 10 HP
SAÍDA 1/2 POLEGADA - 63 dB
1490 X 554 X 1609 - 351 KG
DEPÓSITO DE 270 LTS
COM SECADOR INCORPORADO



RENNER



Model	Free air delivery ⁽¹⁾				Motor power	
	7.5 bar		10 bar		kW	HP
	m ³ /min	cfm	m ³ /min	cfm		
RSDK-PRO-ECN 3.0	0.54	19	0.41	15	3.0	4.0
RSDK-PRO-ECN 4.0	0.69	24	0.55	20	4.0	5.5
RSDK-PRO-ECN 5.5	0.91	32	0.78	28	5.5	7.5
RSDK-PRO-ECN 7.5	1.25	44	1.09	38	7.5	10.0
RSDK-PRO-ECN 11.0	1.61	57	1.56	55	11.0	15.0

RSDK PRO ECN 11.0

€ 9.450

11 KW DE POTÊNCIA - 15 HP
SAÍDA 1/2 POLEGADA - 70 dB
1490 X 554 X 1609 - 369 KG
DEPÓSITO DE 270 LTS
COM SECADOR INCORPORADO





COMPRESSORES DE TRANSMISSÃO DIRETA



N50000C

€ 660

2 CILINDROS - 11 BAR MAX - 400 V
MOTOR 5.5 HP - 4 KW - NB5
660 L/MIN - 1100 RPM



N10002A

€ 1.290

2 CILINDROS - 11 BAR MAX - 400 V - NB10
MOTOR 10 HP - 7.5 KW - 1130 L/MIN - 900 RPM

N70001C

€ 890

2 CILINDROS - 11 BAR MAX - 400 V - NB7
MOTOR 7.5 HP - 5.5 KW - 950 L/MIN - 750 RPM



2800000

€ 290

2 CILINDROS - 10 BAR MAX - 230 V - B2800
MOTOR 2 HP - 1.5 KW - 254 L/MIN - 1250 RPM
MOTOR 3 HP - 2.2 KW - 320 L/MIN - 1570 RPM



370000B

€ 360

2 CILINDROS - 10 BAR MAX - 230 V - B3800
MOTOR 3 HP - 2.2 KW - 387 L/MIN - 1100 RPM
MOTOR 4 HP - 3 KW - 476 L/MIN - 1400 RPM

COMPRESSOR TRANSMISSÃO DIRETA

FCBB404ABC
COM ÓLEO
6 LITROS - 2850 RPM
220 V - 2 HP - 8 BAR
ASPIRAÇÃO 220 LT / MIN

€ 134



RCCC404 - 25 KG
COM ÓLEO - 2850 RPM
24 LITROS - RC2/24
220 V - 2 HP - 8 BAR
ASPIRAÇÃO 210 LT / MIN

€ 189



RCDV404 - 36 KG
COM ÓLEO - 2850 RPM
50 LITROS - RC2/50
220 V - 2 HP - 8 BAR
ASPIRAÇÃO 210 LT / MIN

€ 249



COMPRESSORES DE PISTON



COMPRESSOR TRANSMISSÃO POR CORREIAS

B2800/50 CM2
2 CILINDROS EM FERRO FUNDIDO
50 LT - 1250 RPM - CABEÇA EM ALUMINIO
220 V - 2 HP - 10 BAR - 50 LT
ASPIRAÇÃO 255 LT / MIN

€ 474 28DC404 - 220 V

del'air



B2800/100 CM2 - B2800/100 CT2
2 CILINDROS EM FERRO FUNDIDO
100 LT - 1250 RPM - CABEÇA EM ALUMINIO
2 HP - 10 BAR - 100 LT
ASPIRAÇÃO 255 LT / MIN

€ 528 28FC404 - 220 V

€ 531 28FC441- 400 V

del'air



B3800B/200 CM3 - B3800B/200 CT3
2 CILINDROS EM FERRO FUNDIDO
200 LT - 1200/1570 RPM - CABEÇA EM ALUMINIO
3 HP - 10 BAR - 200 LT
ASPIRAÇÃO 390 LT / MIN

€ 748 36LC504 - 220 V

€ 749 36LC541 - 400 V



COMPRESSORES DE PISTON

COMPRESSOR TRANSMISSÃO POR CORREIAS

B3800B/270 CT4
2 CILINDROS EM FERRO FUNDIDO
270 LT - 1400 RPM - CABEÇA EM ALUMINIO
4 HP - 10 BAR
400 V - 270 LT
ASPIRAÇÃO 480 LT / MIN

36NC601

€ 929



del'air

NB5/5.5CT/270
2 CILINDROS EM FERRO FUNDIDO
270 LT - 1370 RPM
CABEÇA EM ALUMINIO NS39
BISTADIO - 5.5 HP
400 V - 10 BAR - 270 LT
ASPIRAÇÃO 582 LT / MIN

N5NC701

€ 1.260



del'air

NB7/7.5CT/270
2 CILINDROS EM FERRO FUNDIDO
270 LT - 1450 RPM
CABEÇA EM ALUMINIO NS59
BISTADIO - 7.5 HP
400 V - 10 BAR - 270 LT
ASPIRAÇÃO 860 LT / MIN

N7NC801

€ 1.490



del'air

NB10/10CT/270
2 CILINDROS EM FERRO FUNDIDO
270 LT - 950 RPM
CABEÇA EM ALUMINIO NS59S
BISTADIO - 10 HP
400 V - 10 BAR
ASPIRAÇÃO 1230 LT / MIN

N1NC901

€ 2.130





COMPRESSORES DE PISTON

PÁS DE PROJECTAR REBOCO PAREDE

NC 223 P4 - 4 ORIFÍCIOS DE SAÍDA
INDICADO PARA REBOCAR PAREDES
GRANDE VELOCIDADE DE REBOCO
CONSUMO MÍNIMO 350 L/MIN
INOX

€ 246

PÁS DE PROJECTAR REBOCO TECTO

NC 228 S4 - 4 ORIFÍCIOS DE SAÍDA
INDICADO PARA REBOCAR TECTOS
GRANDE VELOCIDADE DE REBOCO
CONSUMO MÍNIMO 350 L/MIN
INOX

€ 246



del'air

Compressores DEL'AIR com centralina de arranque temporizado

Os compressores DEL'AIR de duas cabeças, com pistons de diâmetros diferentes (BISTADIO) oferecem um ótimo desempenho para uma utilização regular.

Com uma gestão de arranque temporizado, garantem um arranque progressivo evitando sobrecarga na tensão.

DEL'AIR é a nossa marca registada, no ar comprimido sendo uma solução de elevada qualidade a um preço competitivo.

Descubra toda uma gama de compressores profissional.

B3800/270FT3+3TD
2 CILINDROS EM FERRO FUNDIDO
270 LT - 1300 RPM
CABEÇA EM ALUMINIO NS39S
3 + 3 HP
400 V - 10 BAR
ASPIRAÇÃO 780 LT / MIN



B3800B/270FT4+4 TD
2 CILINDROS EM FERRO FUNDIDO
270 LT - 1450 RPM
CABEÇA EM ALUMINIO NS59S
4 + 4 HP BISTADIO
400 V - 10 BAR
ASPIRAÇÃO 960 LT / MIN

36NW541 € 1.520

36NW601 € 1.890

del'air

PRESSOSTATOS

MONOFÁSICO 12 BAR
BLOCO DE 4 VIAS

41090051 € 19.9

TRIFÁSICO 12 BAR
BLOCO DE 4 VIAS

41090121 € 22.9

TRIFÁSICO
COM TÉRMICO DE PROTEÇÃO
BLOCO DE 4 VIAS

ET24V6/10

€ 82





COMPRESSORES SILENCIOSOS

COMPRESSOR TRANSMISSÃO POR CORREIAS

DELAIR AIRSIL2

4 HP

NB4/4T 400 V

N4AT601

€ 2.144

DELAIR AIRSIL2

5.5 HP

NB5/5.5FT 400 V

N5AT701

€ 2.650

DELAIR AIRSIL3

10 HP

NB10/10FT 400V

NIAT901

€ 2.980



Painel de controlo de fácil leitura. Versões com estrela triângulo têm aviso electrónico de falhas.



Equipado com porta frontal para facilitar a manutenção. Nível de óleo facilmente visível e a recarga é simples graças ao posicionamento da cabeça.



Cabeça potente que assegura um enorme desempenho e uma elevada fiabilidade.

del'air

SILENCIOSO COM DEPÓSITO

SOLUÇÃO INTEGRADA

DELAIR AIRSIL2

4 HP - 400 V - 270 LT

NB4/4FT/270

€ 2.470

DELAIR AIRSIL2

5.5 HP - 400 V - 270 LT

NB5/5.5FT/270

€ 2.690

DELAIR AIRSIL2

7.5 HP - 400 V - 270 LT

NB7/7.5FT/270

€ 2.780



SECADORES DE AR



- € 899
AMD 6 - 600 L/min :: 36 m³/H :: 1/2" BSP-F :: 230 V :: 370X515X475 :: SCFM 21
- € 970
AMD 9 - 950 L/min :: 57 m³/H :: 1/2" BSP-F :: 230 V :: 370X515X475 :: SCFM 34
- € 1.090
AMD 12 - 1200 L/min :: 72 m³/H :: 1/2" BSP-F :: 230 V :: 370X515X475 :: SCFM 42
- € 1.160
AMD 18 - 1800 L/min :: 108 m³/H :: 1/2" BSP-F :: 230 V :: 370X515X475 :: SCFM 64
- € 1.350
AMD 25 - 2500 L/min :: 150 m³/H :: 1" BSP-F :: 230 V :: 345X420X740 :: SCFM 88
- € 1.710
AMD 32 - 3200 L/min :: 192 m³/H :: 1 1/4" BSP-F :: 230 V :: 345X445X740 :: SCFM 113
- € 2.100
AMD 43 - 4300 L/min :: 258 m³/H :: 1 1/4" BSP-F :: 230 V :: 345X445X740 :: SCFM 152
- € 2.330
AMD 52 - 5200 L/min :: 312 m³/H :: 1 1/4" BSP-F :: 230 V :: 485X455X825 :: SCFM 184
- € 2.680
AMD 61 - 6100 L/min :: 366 m³/H :: 1 1/2" BSP-F :: 230 V :: 555X580X885 :: SCFM 216

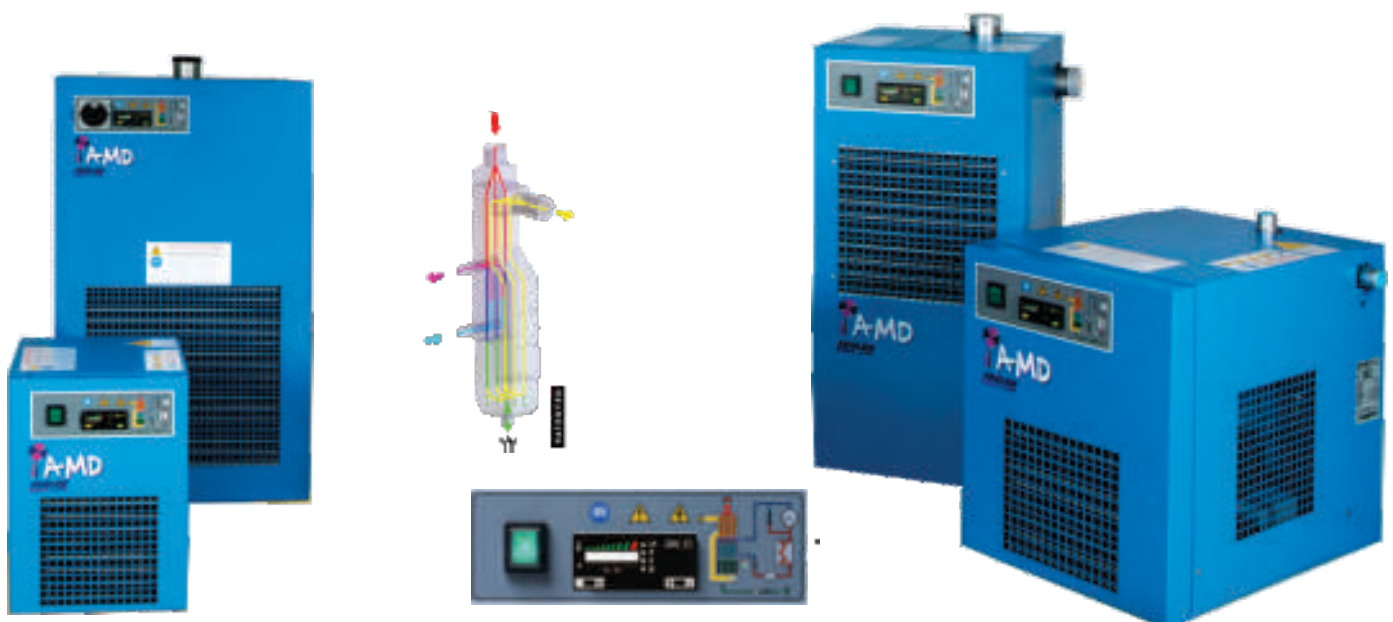



ACT Dryer Series

ACT 5 - GÁS R134.a :: 550 L/min :: 21 m ³ /H :: 1/2" BSP-F :: 230 V :: 345X420X740 :: SCFM 12	€ 1.008
ACT 8 - GÁS R134.a :: 850 L/min :: 51 m ³ /H :: 1/2" BSP-F :: 230 V :: 345X420X740 :: SCFM 19	€ 1.160
ACT 12 - GÁS R134.a :: 1200 L/min :: 72 m ³ /H :: 1/2" BSP-F :: 230 V :: 345X420X740 :: SCFM 42	€ 1.370
ACT 18 - GÁS R134.a :: 1800 L/min :: 108 m ³ /H :: 1" BSP-F :: 230 V :: 345X420X740 :: SCFM 64	€ 1.640
ACT 23 - GÁS R134.a :: 2300 L/min :: 138 m ³ /H :: 1" BSP-F :: 230 V :: 345X420X740 :: SCFM 81	€ 1.850
ACT 30 - GÁS R407C :: 3100 L/min :: 138 m ³ /H :: 1 1/4" BSP-F :: 230 V :: 485X455X825 :: SCFM 109	€ 2.320
ACT 40 - GÁS R407C :: 4000 L/min :: 138 m ³ /H :: 1 1/4" BSP-F :: 230 V :: 485X455X825 :: SCFM 141	€ 2.590
ACT 55 - GÁS R407C :: 5500 L/min :: 330 m ³ /H :: 1. 1/2" BSP-F :: 230 V :: 555X580X885 :: SCFM 194	€ 2.870
ACT 60 - GÁS R407C :: 6200 L/min :: 372 m ³ /H :: 1. 1/2" BSP-F :: 230 V :: 555X580X885 :: SCFM 219	€ 3.050
ACT 80 - GÁS R407C :: 8100 L/min :: 486 m ³ /H :: 2" BSP-F :: 230 V :: 555X625X975 :: SCFM 286	€ 4.530



SCFM - STANDARD CUBIC FEET PER MINUTE

Pés cúbicos padrão por minuto (SCFM) é a taxa de fluxo de um gás ou ar através de um compressor em condições padrão de temperatura e pressão.

A temperatura padrão para calcular a vazão do SCFM varia de 60°F a 68°F, a uma pressão de 14,7psi e umidade relativa de 36%. Como o SCFM mede o fluxo de ar volumétrico em condições padrão, ele é sempre superior que o valor CFM para um compressor de ar.





DEPÓSITOS DE ACESSÓRIOS

DEPÓSITOS VERTICAIS
DEL'AIR



INCLUI MANÓMETRO E
VÁLVULA NÃO AFERIDOS



SV 270 - DEPÓSITO AR COMPRIMIDO 270 LTS

€ 519

S 500 - DEPÓSITO AR COMPRIMIDO 500 LTS

€ 906

S 720 - DEPÓSITO AR COMPRIMIDO 720 LTS

€ 1.200

S 1000 - DEPÓSITO AR COMPRIMIDO 900 LTS

€ 1.430

S 2000 - DEPÓSITO AR COMPRIMIDO 2000 LT

€ 3.510



PURGA AUTOMÁTICA 1/2



ENTRADA - 1/2
SAÍDA - Ø 6 - 230 V

90990

€ 132

PURGA AUTOMÁTICA 3/4



ENTRADA - 3/4
SAÍDA - Ø 6 - 230 V

2215SCE005N

€ 214



ACESSÓRIOS PARA LINHAS DE AR



19900000010 - VÁLVULA CERTIFICADA
10 BAR

€ 225

19900000040 - VÁLVULA CERTIFICADA
14 BAR

€ 225



10101322210 - MANÓMETRO CERTIFICADO 10 BAR

€ 145

10101322214 - MANÓMETRO CERTIFICADO 14 BAR

€ 145

VALIDADE CERTIFICAÇÃO 1 ANO



**PRÉ-FILTROS SEPARADORES DE ÓLEO SERIES
LFS DE 1 MICRON E LFX DE 0.01 MICRON PARA
LINHAS DE AR COM COMPRESSORES DE PARAFUSO**



LFS006 - 1 MICRON - 1/2"
550 L/MIN

€ 110

LFS012 - 1 MICRON - 3/4"
1200 L/MIN

€ 114

LFS018 - 1 MICRON - 3/4"
1800 L/MIN

€ 122

LFS023 - 1 MICRON - 3/4"
2300 L/MIN

€ 125

LFS039 - 1 MICRON - 1"
3900 L/MIN

€ 145

LFS045 - 1 MICRON - 1 1/4"
4500 L/MIN

€ 182

LFS061 - 1 MICRON - 1 1/4"
6100 L/MIN

€ 210

LFX006 - 0.01 MICRON - 1/2"
550 L/MIN

€ 110

LFX012 - 0.01 MICRON - 3/4"
1200 L/MIN

€ 114

LFX018 - 0.01 MICRON - 3/4"
1800 L/MIN

€ 122

LFX023 - 0.01 MICRON - 3/4"
2300 L/MIN

€ 125

LFX039 - 0.01 MICRON - 1"
3900 L/MIN

€ 140

LFX045 - 0.01 MICRON - 1 1/4"
4500 L/MIN

€ 182

LFX061 - 0.01 MICRON - 1 1/4"
6100 L/MIN

€ 210

ACESSÓRIOS PARA LINHAS DE AR

FILTROS SEPARADORES DE ÁGUA E ÓLEO



MODELO	COMPRESSOR DE PARAFUSO		COMPRESSOR DE PISTON	
	ÓLEO	ÓLEO SINTÉTICO	ÓLEO	ÓLEO SINTÉTICO
WOSS 24	2.4	1.9	1.7	1.4
WOSS 49	4.9	3.8	3.4	2.8
WOSS 73	7.3	5.6	5.1	4.2

WOSS 24 € 495

WOSS 49 € 825

WOSS 73 € 1.480

AIGNEP

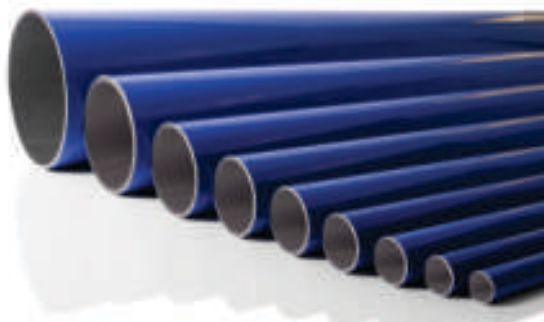

CORES DISPONÍVEIS:



TUBOS PARA CONDUTAS DE AR COMPRIMIDO

ALUMÍNIO CALBRADO CÓD: 90000

MAX 16 BAR - ALUMÍNIO - VARAS 4 METROS

Ø20 € 27,32	Ø40 € 53,60
Ø25 € 33,13	Ø50 € 87,77
Ø32 € 42,85	Ø63 € 105,19

CÓD: 90006

MAX 16 BAR - ALUMÍNIO - VARAS 6 METROS

Ø20 € 37,95	Ø40 € 78,98
Ø25 € 47,71	Ø50 € 120,70
Ø32 € 61,61	Ø63 € 154,97

Dilatações e contrações térmicas

Para calcular a dilatação - contração linear utilizamos a seguinte fórmula:

$$\Delta L = \Delta T \times L \times a \quad \text{onde:}$$

ΔL = Dilatação - contração linear em mm

ΔT = Variação de temperatura entre a temperatura de trabalho e a de instalação em °C

L = Comprimento do tubo em m

a = Coeficiente de dilatação térmica linear que para o alumínio é 0.024 mm/m °C

A instalação deve ser feita de modo que nas extremidades se considere um espaço de permita a dilatação-contração, e os suportes devem ser posicionados como mostra a figura:



LINHAS DE AR COMPRIMIDO

Ø20	Ø25	JOELHO 90° 90130
€ 10,35	€ 15,11	
Ø32	Ø40	
€ 24,40	€ 33,5	

Ø20	Ø25	JOELHO 45° 90140
€ 11,09	€ 15,19	
Ø32	Ø40	
€ 22,89	€ 34,42	

Ø20	Ø32	TÊ 90230
€ 14,84	€ 33,66	
Ø25	Ø40	
€ 21,59	€ 47,14	

Ø20	Ø25	UNIÃO 90040
€ 10,04	€ 13,75	
Ø32	Ø40	
€ 21,10	€ 31,51	

Ø32 - Ø20	Ø40 - Ø20	PICAGEM PARA BAIXADA 90240
€ 31,27	€ 37,64	
Ø40 - Ø25	Ø50 - Ø25	
€ 38,90	€ 47,36	

Ø20 - 1/2	REPARTIDOR COM VÁLVULA 90664
€ 45,07	
Ø25 - 1/2	
€ 58,42	

Ø20	Ø25	VÁLVULA 90700
€ 27,32	€ 38,75	
Ø32	Ø40	
€ 56,15	€ 82,42	

Ø20 - 1/2	Ø25 - 3/4	BAIXADA COM PATER 90600
€ 10,40	€ 12,72	
Ø32 - 1"		
€ 18,96		

Ø20 - 1/2	Ø20 - 3/4	Ø25 - 1/2	Ø25 - 3/4	UNIÃO DE TRANSIÇÃO 90010
€ 6,56	€ 7,77	€ 8,68	€ 8,68	
Ø32 - 1"	Ø40 - 1"	Ø40 - 1 1/4	Ø40 - 1 1/2	
€ 13,56	€ 19,68	€ 19,68	€ 25,66	



Ø20 - Ø20	Ø25 - Ø20	Ø32 - Ø20	Ø32 - Ø25	TÊ DE BAIXADA 90235
€ 16,95	€ 22,5	€ 30,26	€ 31,27	
Ø40 - 20	Ø40 - 25			
€ 43,36	€ 44,48			



ACESSÓRIOS PARA PNEUMÁTICA



FILTRO REGULADOR DE PRESSÃO

1 - 3/8 € 25



FILTRO REGULADOR DE PRESSÃO

2 - 1/2 € 27



FILTRO REGULADOR DE PRESSÃO

3 - 3/8 € 26

4 - 1/2 € 27

INFLATOR DUPLO 300 COM PEGA



MOD. T1 € 8,5

INFLATOR DUPLO



MOT. T2 € 5,9

PISTOLA SILICONE



28 G € 20,9

APLIQUE DIRETO



27D € 2,1

PISTOLA DE AR



27 B € 4,5

PISTOLA DE AR



27A € 3,6

PISTOLA DECAPAR



28 HSS € 31,5

AERÓGRAFO Ø 0.2/0.3



MOD. A1 € 169

B5 5 € 10



PISTOLA LAVAGEM

28BA € 12,9

PIPO PARA ÁGUA



26 D € 6,2

PISTOLA REGULÁVEL



27P € 5,9



PISTOLA LAVAGEM

28A € 9,2



PISTOLA LAVAGEM

28B € 10,6

CONJUNTO PISTOLA E MANGUEIRA



27 A TRUCK € 19,9



ACESSÓRIOS PARA PNEUMÁTICA

ENGATE UNIVERSAL
FÊMEA



15A2U

1/4 M	€ 2,7
3/8 M	€ 2,7
1/2 M	€ 3,05

ENGATE UNIVERSAL
MACHO



13AM

1/8 M	€ 0,56
1/4 M	€ 0,58
3/8 M	€ 0,89
1/2 M	€ 1,19

ENGATE UNIVERSAL
FÊMEA



142U

6 MM	€ 2,95
8 MM	€ 2,95
10 MM	€ 3,05
12 MM	€ 3,15

ENGATE UNIVERSAL
FÊMEA



14A2U

6X14	€ 4,06
6X15	€ 4,06
8X16	€ 4,06
8X17	€ 4,06
10X17	€ 4,90
10X19	€ 4,90

ENGATE UNIVERSAL
FÊMEA



15C2U

1/8 M	€ 3,5
1/4 M	€ 3,5
3/8 M	€ 3,5
1/2 M	€ 4,44

ENGATE UNIVERSAL
MACHO



13AF

1/8 M	€ 0,59
1/4 M	€ 0,61
3/8 M	€ 0,89
1/2 M	€ 1,25

ENGATE DE APERTO



18A

1/8 M	€ 3,07
1/4 M	€ 3,21
3/8 M	€ 3,21
1/2 M	€ 3,72

ENGATE MACHO MACHO



MOD. 12

6	€ 0,71
8	€ 0,71
10	€ 0,78
12	€ 0,84

ENGATE FEMÊA



38F3U

4X6	€ 3,9
6X8	€ 3,99
8X10	€ 3,99
10X12	€ 4,2

TUBO NYLON DIREITO
B8



Ø6-8	€ 53
Ø8-10	€ 68
Ø10-12	€ 83

TUBO RILSAN DIREITO
B7 - ROLO 100 METROS

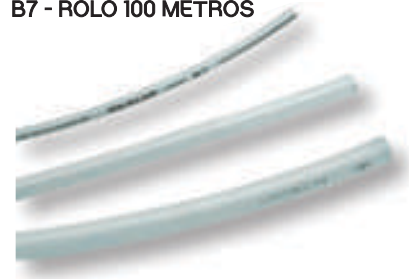

Ø6-8	€ 90
Ø8-10	€ 116
Ø10-12	€ 132

ACESSÓRIOS PARA PNEUMÁTICA



SUPER PROFISSIONAL

MANOMETRO CE Ø80
0-12 BAR
27GSP RIF.2

€ 34.7



PROFISSIONAL

MANOMETRO Ø63
0-12 BAR 27G

€ 12,5

SUPER PROFISSIONAL

MANOMETRO Ø63

27G1 € 23



MANOMETRO Ø80
0-12 BAR
CERTIFICADA CE
27G CE

€ 21



28 C

DISPONÍVEL COM BICO
DE 1.2 MM OU 1.4 MM

28C12
28C14 € 19.6



28DS

DISPONÍVEL COM BICO
1.4 MM

28DS14

€ 36.2

THE FIRST



COPO SUPERIOR
1.4 MM SUPER PRO
400-500 LT/MIN

THEFIRSTTS14

€ 77.5



COPO INFERIOR
1.4 MM SUPER PRO
400-500 LT/MIN

THEFIRST14

€ 96

ACESSÓRIOS PARA PNEUMÁTICA



NOVO MODELO
MAIS FÁCIL DE LIMPAR
COM MICRÓMETRO E REGULADOR
PARA UMA PINTURA PERFEITA
MINIMIZA O DESPERDÍCIO
MANÓMETRO PARA CONTROLO
IMEDIATO DA PRESSÃO UTILIZADA



INFINITY HVLP

€ 166



REGULADOR
DE PRESSÃO

0-12 BAR Ø40
1/4

04POS2

€ 11



REGULADOR

R 1/4

€ 18

R 3/8

€ 34

R 1/2

€ 92

R 3/4

€ 92

R 1"

€ 92



FILTRO AR

FM 1/4

€ 23

FM 3/8

€ 33

FM 1/2

€ 82

FM 3/4

€ 82

FM 1"



FILTRO AR +
DEPURADOR

FDM1/4

€ 85

FDM3/8

€ 100

FDM1/2

€ 100



LUBRIFICADOR AR

LM 1/4

€ 21

LM 3/8

€ 34

LM 1/2

€ 95

LM 3/4

€ 95

LM 1"



FILTRO REGULADOR AR

FRM 1/4

€ 36

FRM 3/8

€ 47

FRM 1/2

€ 155

FRM 3/4

€ 155

FRM 1"



GRUPO FILTRO +
LUBRIFICADOR

FRL2M1/4

€ 58

FRL2M3/8

€ 86

FRL2M1/2

€ 97



GRUPO FILTRO +
REGULADOR E LUBRIFICADOR

FRL3M1/4

€ 63

FRL3M3/8

€ 94

FRL3M1/2

€ 260

FRL3M3/4

€ 260

FRL3M1"



SECADOR DE AR
LINHA S

S3/8

€ 102

S1/2

€ 298



MR63 - 1/4

€ 9.10



MP40 - 1/8
MP50 - 1/4

€ 7.2

DEPURADOR AR

DM 1/4

€ 64

DM 3/8

€ 76

DM 1/2

€ 95





















DM 3/4

€ 95

DM 1"



ACESSÓRIOS PARA PNEUMÁTICA

	3/8 € 3,21		1/4 € 1,05		1/4-1/8 € 0,41
	1/2 € 3,21		3/8 € 1,10		3/8-1/8 € 0,65
			1/2 € 1,35		3/8-1/4 € 0,66
	1/2-1/2 € 5,23		1/4 € 1,46		1/2-1/8 € 1,04
			3/8 € 2,29		1/2-1/4 € 1,04
			1/2 € 5,88		1/2-3/8 € 1,05
	1/4 € 1,31		1/4 € 1,46		3/4-1/4 € 1,05
	3/8 € 2,29		3/8 € 2,29		3/4-3/8 € 1,76
	1/2 € 4,90		1/2 € 5,88		3/4-1/2 € 1,58
	1/4 € 1,31				1'-3/8 € 4,34
	3/8 € 2,29				
	1/2 € 4,90				
	1/4 € 1,31		M1/4-F1/4 € 0,51		1/4-1/4 € 0,54
	3/8 € 2,29		M1/4-F3/8 € 0,66		3/8-3/8 € 0,75
	1/2 € 4,90		M1/4-F1/2 € 1,17		1/2-1/2 € 1,04
			M3/8-F3/8 € 0,73		1/4-3/8 € 0,75
			M3/8-F1/2 € 1,22		1/4-1/2 € 1,07
			M1/2-F1/2 € 1,24		3/8-1/2 € 1,09
			M1/2-F3/4 € 2,33		1/2-3/4 € 2,02
			M3/4-F3/4 € 2,26		3/4-3/4 € 2,24
	1/4 € 2,56		1/4 € 2,56		1/4 € 2,05
	3/8 € 4,04		3/8 € 4,04		3/8 € 3,20
	1/2 € 8,68		1/2 € 8,68		1/2 € 6,42
	1/4 € 2,05		1/4 € 2,56		1/4 € 2,05
	3/8 € 3,20		3/8 € 4,04		3/8 € 3,20
	1/2 € 6,42		1/2 € 8,68		1/2 € 6,42
	1/4 € 2,05		1/4 € 2,05		1/4 € 2,05
	3/8 € 3,20		3/8 € 3,20		3/8 € 3,20
	1/2 € 6,42		1/2 € 6,42		1/2 € 6,42



ACESSÓRIOS PARA PNEUMÁTICA



1/4-1/4	€ 0,51
3/8-3/8	€ 0,70
1/2-1/2	€ 1,01
1/8-1/4	€ 0,53
1/8-3/8	€ 0,56
1/8-1/2	€ 0,93
1/4-3/8	€ 0,63
1/4-1/2	€ 0,97
3/8-1/2	€ 0,97
1/2-3/4	€ 1,97
3/4-3/4	€ 1,96
1'-1'	€ 3,64



CILINDRICO

Ø6	€ 1,52
Ø8	€ 2,17
Ø10	€ 2,76
Ø12	€ 3,94



AP5

1/4	€ 1,52
3/8	€ 2,17
1/2	€ 2,76



VS

Ø8-6	€ 0,94
Ø10-8	€ 1,24
Ø12-10	€ 1,34



API7

Ø6	€ 0,88
Ø8	€ 0,94
Ø10	€ 1,30
Ø12	€ 1,68



API4



30M



18B



AP3



AP6

1/4-1/4	€ 0,47
3/8-3/8	€ 0,78
1/2-1/2	€ 1,23
1/4-3/8	€ 0,79
1/4-1/2	€ 1,41
3/8-1/2	€ 1,46
1/2-3/4	€ 2,71
3/4-3/4	€ 2,50

1/4	€ 3,88
3/8	€ 3,88
1/2	€ 4,41

1/4 - Ø6	€ 1,26
3/8 - Ø6	€ 1,55
1/4 - Ø8	€ 1,84
3/8 - Ø8	€ 1,84
1/2 - Ø8	€ 3,15
1/4 - Ø10	€ 1,71
3/8 - Ø10	€ 2,63
1/2 - Ø10	€ 3,02

M5 - Ø6	€ 0,90
1/8 - Ø6	€ 0,97
1/4 - Ø6	€ 1,16
3/8 - Ø6	€ 1,44

1/8 - Ø8	€ 1,16
1/4 - Ø8	€ 1,22
3/8 - Ø8	€ 1,38
1/2 - Ø8	€ 2,17
1/8 - Ø10	€ 1,90
1/4 - Ø10	€ 1,55
3/8 - Ø10	€ 1,58
1/2 - Ø10	€ 2,36

TAMPÃO 1/4	€ 2,05
3/8	€ 3,20
1/2	€ 6,42
29 B2 3/4	€ 00,0

R7 1/4	€ 4,62
3/8	€ 4,62
1/2	€ 5,23
3/4	€ 7,81

R8 1/4	€ 4,14
3/8	€ 4,14
1/2	€ 4,68
3/4	€ 6,99

M5 - Ø6	€ 0,73
1/4 - Ø6	€ 0,68
3/8 - Ø6	€ 1,05
1/4 - Ø8	€ 0,81
3/8 - Ø8	€ 0,95
1/2 - Ø8	€ 1,58
1/4 - Ø10	€ 1,04
3/8 - Ø10	€ 1,04
1/2 - Ø10	€ 1,50
3/8 - Ø12	€ 1,38
1/2 - Ø12	€ 1,56

Ø6	€ 1,24
Ø8	€ 1,34
Ø10	€ 1,76
Ø12	€ 2,29

Ø6	€ 0,94
Ø8	€ 0,98
Ø10	€ 1,24
Ø12	€ 1,94

ACESSÓRIOS PARA PNEUMÁTICA

	M5 - Ø6	€ 2,04
	1/4 - Ø6	€ 1,55
	3/8 - Ø6	€ 2,36
	1/4 - Ø8	€ 1,61
	3/8 - Ø8	€ 1,89
	1/2 - Ø8	€ 2,76
	1/4 - Ø10	€ 2,30
	3/8 - Ø10	€ 2,43
	1/2 - Ø10	€ 3,22
	3/8 - Ø12	€ 4,01
	1/2 - Ø12	€ 3,57



	M5 - Ø6	€ 1,64
	1/4 - Ø6	€ 1,64
	3/8 - Ø6	€ 2,04
	1/4 - Ø8	€ 1,77
	3/8 - Ø8	€ 2,10
	1/2 - Ø8	€ 2,82
	1/4 - Ø10	€ 2,15
	3/8 - Ø10	€ 2,18
	1/2 - Ø10	€ 2,50
	3/8 - Ø12	€ 3,15
	1/2 - Ø12	€ 3,81



	M5 - Ø6	€ 1,55
	1/4 - Ø6	€ 1,75
	3/8 - Ø6	€ 2,07
	1/4 - Ø8	€ 1,92
	3/8 - Ø8	€ 2,10
	1/2 - Ø8	€ 2,91
	1/4 - Ø10	€ 2,36
	3/8 - Ø10	€ 2,47
	1/2 - Ø10	€ 3,09
	3/8 - Ø12	€ 2,89
	1/2 - Ø12	€ 3,22

	Ø6	€ 1,45
	Ø8	€ 1,55
	Ø10	€ 1,81
	Ø12	€ 2,15



	M5 - Ø6	€ 2,13
	1/4 - Ø6	€ 1,89
	3/8 - Ø6	€ 2,22
	1/4 - Ø8	€ 2,21
	3/8 - Ø8	€ 2,26
	1/2 - Ø8	€ 3,28
	1/4 - Ø10	€ 2,82
	3/8 - Ø10	€ 2,86
	1/2 - Ø10	€ 3,37



	1/8 - Ø6	€ 1,17
	1/4 - Ø6	€ 1,26
	3/8 - Ø6	€ 1,55
	1/8 - Ø8	€ 1,24
	1/4 - Ø8	€ 1,84
	3/8 - Ø8	€ 1,84
	1/2 - Ø8	€ 3,15
	1/8 - Ø10	€ 1,71
	1/4 - Ø10	€ 1,71
	3/8 - Ø10	€ 2,63
	1/2 - Ø10	€ 3,02

	Ø6	€ 2,31
	Ø8	€ 2,42
	Ø10	€ 2,84
	Ø12	€ 2,94



	Ø6	€ 1,52
	Ø8	€ 2,17
	Ø10	€ 2,76
	Ø12	€ 3,94

KIT PINTURA BEERGMAN EM CAIXA DE CARTÃO

AA500K € 18



PISTOLA DE PINTURA COPO SUPERIOR

WF108AL € 16



PISTOLA DE PINTURA COM COMPRESSOR 220 V

ES1 € 26,5



PISTOLA DE PINTURA COPO INFERIOR 1 LT

4001S € 20





AR COMPRIMIDO



TUBOS PARA INDÚSTRIA

COMPOSTO DE BORRACHA SBR / EPDM ,
RESISTENTE À ABRASÃO E ÀS INTEMPÉRIES

BITUBO PARA OXIGÉNIO E GÁS

6+6 € 2,83 8+8 € 3,35

PREÇO POR METRO WELTWIN 20



MEDIDA INTERIOR		MEDIDA EXTERIOR		PESO	WP		BP		ROLOS
mm	inch	mm	inch	kg/m	bar	psi	bar	psi	m
6+6	1/4 +1/4	13	1/2	0.35	20	300	60	900	50/100
8+8	5/16 +5/16	15	19/32	0.40	20	300	60	900	50/100



TUBO DE SUÇÃO E DISTRIBUIÇÃO PARA ÁGUA QUENTE,
LÍQUIDOS REFRIGERANTES. MUITO FLEXÍVEL

TUBO PARA RADIADORES

25X33 € 14,5 CALORFLEX SD/5
28X36 € 15,35 PREÇO POR METRO



MEDIDA INTERIOR		PESO	WP		BP		RAIO DE DOBRA	VACUO	ROLOS
mm	inch	kg/m	bar	psi	bar	psi	mm	bar	m
15	19/32	0.42	5	75	15	225	55	0.8	40
16	5/8	0.45	5	75	15	225	60	0.8	40
18	45/64	0.48	5	75	15	225	65	0.8	40
19	3/4	0.50	5	75	15	225	70	0.8	40
20	25/32	0.52	5	75	15	225	70	0.8	40
22	7/8	0.54	5	75	15	225	75	0.8	40
25	1	0.58	5	75	15	225	85	0.8	40
28	1 7/64	0.64	5	75	15	225	95	0.8	40
30	1 3/16	0.68	5	75	15	225	100	0.8	40
32	1 1/4	0.73	5	75	15	225	105	0.8	40
35	1 3/8	0.82	5	75	15	225	115	0.8	40
38	1 1/2	0.93	5	75	15	225	130	0.8	40
40	1 37/64	1.00	5	75	15	225	135	0.8	40
42	1 21/32	1.05	5	75	15	225	140	0.8	40
45	1 25/32	1.18	5	75	15	225	150	0.8	40
50	1 31/32	1.30	5	75	15	225	165	0.8	40
55	2 11/64	1.50	5	75	15	225	180	0.8	40
60	2 23/64	1.70	5	75	15	225	200	0.8	40
63.5	2 1/2	1.74	5	75	15	225	210	0.8	40
70	2 3/4	2.00	5	75	15	225	220	0.8	40
76	3	2.17	5	75	15	225	250	0.8	40
80	3 5/32	2.25	5	75	15	225	270	0.8	40
90	3 35/64	2.57	5	75	15	225	300	0.8	40
102	4	3.17	5	75	15	225	340	0.8	40

OUTROS DIÂMETROS E PRESSÕES ESTÃO DISPONÍVEIS MEDIANTE PEDIDO. DADOS TÉCNICOS, ESTRUTURAIS E POLÍMEROS PODEM SER ALTERADOS SEM AVISO PRÉVIO.

TUBOS PARA INDÚSTRIA

TUBOS PARA TRANSPORTE, ENTREGA E RECOLHA DE LÍQUIDOS E SÓLIDOS, RESISTENTES À ABRASÃO E INTEMPÉRIES. LISOS E CORRUGADOS.

TUBOS PARA ÁGUA
BORRACHA SBR
PARA FLUÍDOS INERTES
NÃO CORROSIVOS



TUBOS PARA ÁGUA
BORRACHA EPDM
LONGAS DISTÂNCIAS
ÁGUAS E DETERGENTES



TUBOS PARA PROPANO
BORRACHA NBR
LINHAS GPL, INDÚSTRIA
E SOLDADURA



TUBOS PARA CERVEJA
BORRACHA NBR
VINHO, ÁLCOOL, ALIMENTAR
REFRIGERANTES



TUBOS PARA VAPOR
BORRACHA EPM
PARA RADIORES,
REFRIGERAÇÃO...



TUBOS PARA ÁGUA
BORRACHA EPDM
INDÚSTRIA DO VIDRO
NÃO CONDUTORA



TUBOS PARA AREIA
ANTIESTÁTICO CBR/NR/PVC
PARA DECAPAGENS A
AREIA E GRANALHA



TUBOS PARA GASES
BORRACHA EPDM
EXTRACÇÃO DE GASES
OFICINAS, INDUSTRIA, ETC



TUBOS PARA ÁGUA
BORRACHA EPDM
LONGAS DISTÂNCIAS
ÁGUAS E DETERGENTES



TUBOS PARA AR COMP
BORRACHA SBR/EPDM
AR COMP. E FLUÍDOS IN.
REFORÇO DE FIO DE AÇO



TUBOS SUÇÃO
CORRUGADO CR
PEDRAS, ROCHAS, AREIA
MINAS, TUNEIS, CONSTRUÇÃO



TUBOS BETÃO E GESSO
QUATRO CAMADAS SBR/NR
GESSO, BETÃO, PARA
CAMIÕES BOMBA ETC..



TUBO PARA ACETILENO
WELRED 20 L/L BORRACHA 20 BAR MAX

DIMENSÃO €/MT

8x15 € 1,40



ID		ID		WEIGHT	WP		SP		COL LENGTH
mm	inch	mm	inch		bar	psi	bar	psi	
8	5/8	15	5/2	0,18	20	300	80	800	50/100
8	5/8	15	5/2	0,18	20	300	80	800	50/100
9	3/4	16	5/8	0,24	20	300	80	800	50/100
10	3/8	17	43/4	0,21	20	300	80	800	50/100
13	1/2	23	29/2	0,44	20	300	80	800	50/100
16	5/8	26	1 5/16	0,53	20	300	80	800	50/100
19	3/4	30	1 1/16	0,62	20	300	80	800	50/100
25	1	37	1 23/4	0,84	20	300	80	800	50/100

TUBO DE BORRACHA PARA AR COMPRIMIDO
AERGEN 20 L/L BORRACHA 20 BAR MAX



DIMENSÃO €/MT

6x14 € 1,16

15x25 € 2,54

8x17 € 1,68

16x26 € 2,75

10x19 € 1,71

19x30 € 3,45

13x23 € 2,72

25x32 € 5,30

TUBO DE BORRACHA PARA OXIGÉNIO
WELBLU 20 L/L BORRACHA 20 BAR MAX



DIMENSÃO €/MT

6x13 € 1,12

13x23 € 3,38

8x15 € 1,68

16x26 € 3,92

9x16 € 1,67

19x30 € 5,08

10x17 € 1,86

25x37 € 7,34



MECÂNICA E ELEVAÇÃO



ZAVAGLI





ELEVADOR ELECTRO-MECÂNICO

**Z51 / 3SL
ELECTROMECHANICO**



- CAPACIDADE - 3500 KG
- MOTOR - 3 KW - 4 HP
- 380 V - 50/60 HZ
- TEMPO DE SUBIDA m/S - 0.033
- TEMPO DESCIDA m/S - 0.033
- PORCAS DE SEGURANÇA EM MATERIAL AUTOLUBRIFICANTE
- PROTEÇÃO DE PÉS
- 2650 MM ENTRE COLUNAS
- BRAÇO COM TRINCO DE ROTAÇÃO AUTOMÁTICO

€ 4.480

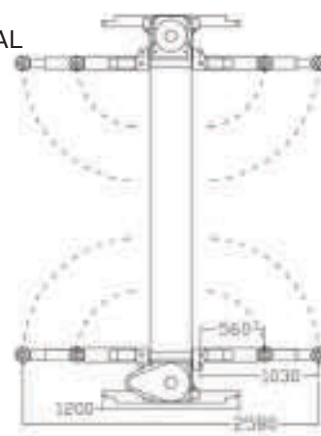
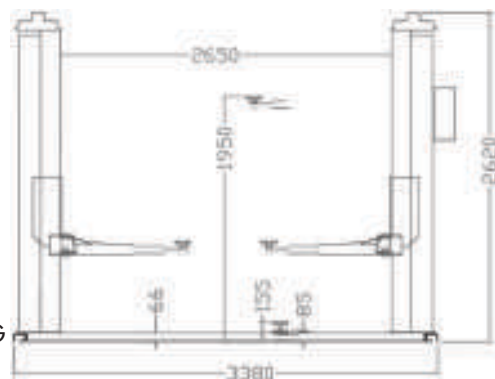

**Z52 / 3S
ELECTROMECHANICO**



- CAPACIDADE - 3500 KG
- 2 MOTORES - 1.1 KW + 1.1 KW
- 380 V - 50/60 HZ
- TEMPO DE SUBIDA m/S - 0.033
- TEMPO DESCIDA m/S - 0.033
- PORCAS DE SEGURANÇA EM MATERIAL AUTOLUBRIFICADNTE
- PROTEÇÃO DE PÉS
- 2480 MM ENTRE COLUNAS
- BRAÇO COM TRINCO DE ROTAÇÃO AUTOMÁTICO

€ 4.860

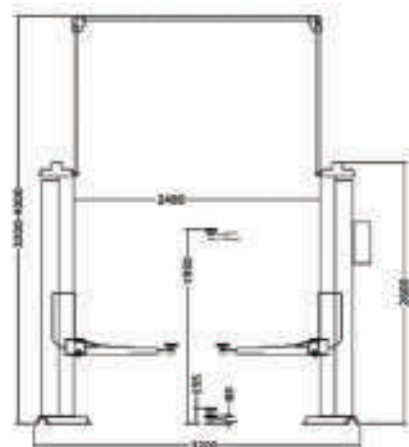
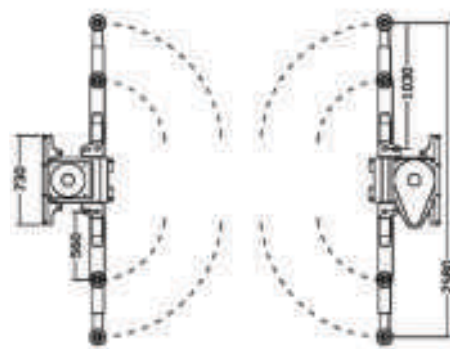



ELEVADOR ELECTRO-MECÂNICO

ZAVAGLI

Z51 / 3S



CAPACIDADE - 3500 KG
 MOTOR - 3 KW - 4 HP
 380 V - 50/60 HZ
 TEMPO DE SUBIDA m/S - 0.033
 TEMPO DESCIDA m/S - 0.033
 PORCAS DE SEGURANÇA EM MATERIAL AUTOLUBRIFICANTE
 BRAÇO COM TRINCO DE ROTAÇÃO AUTOMÁTICO
 PROTEÇÃO DE PÉS
 2480 MM ENTRE COLUNAS

€ 3.850

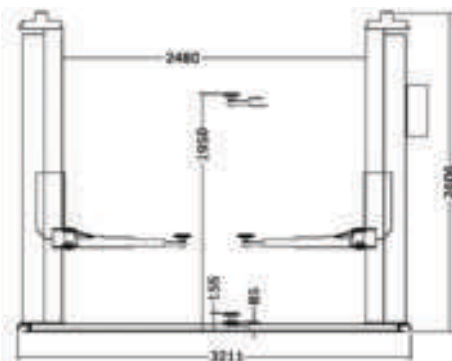
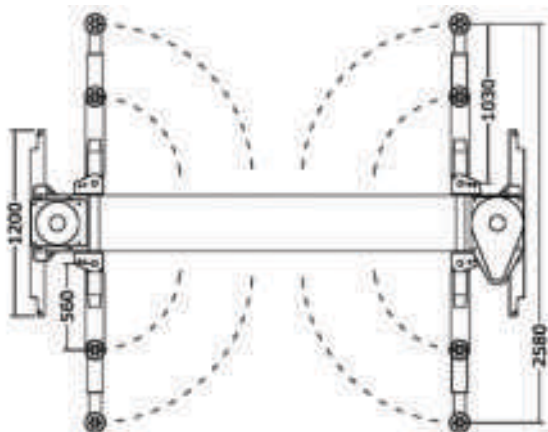

Z4 OPCIONAL

€ 390



ELEVADORES ELECTROHIDRÁULICOS



Z61 / 3S ELECTRO HIDRÁULICO

- CAPACIDADE - 3500 KG
- MOTOR - 1.5 kw
- 380 V - 50/60 HZ
- TEMPO DE SUBIDA m/S - 0.033
- TEMPO DESCIDA m/S - 0.033
- PORCAS DE SEGURANÇA EM MATERIAL AUTOLUBRIFICADNTE
- PROTEÇÃO DE PÉS
- 2480 MM ENTRE COLUNAS
- BRAÇO COM TRINCO DE ROTAÇÃO AUTOMÁTICO

€ 4.530

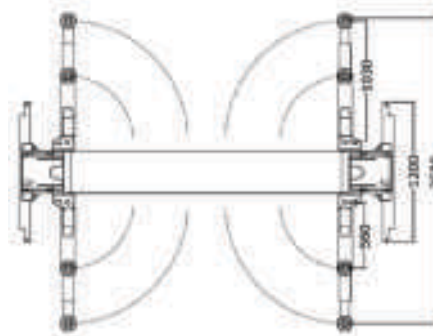
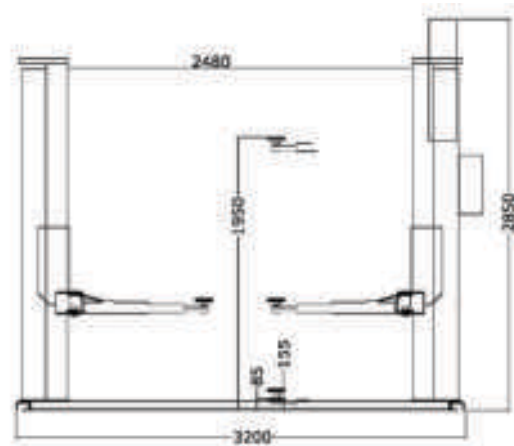

ZAVAGLI



Z63 / 3S ELECTRO HIDRAULICO

- CAPACIDADE - 3500 KG
- MOTOR - 1.5 KW
- 380 V - 50/60 HZ
- TEMPO DE SUBIDA m/S - 0.033
- TEMPO DESCIDA m/S - 0.033
- PROTEÇÃO DE PÉS
- 2480 MM ENTRE COLUNAS
- BRAÇO COM TRINCO DE ROTAÇÃO AUTOMÁTICO

€ 4.750

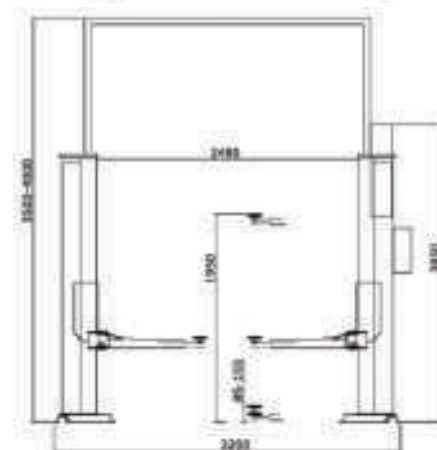
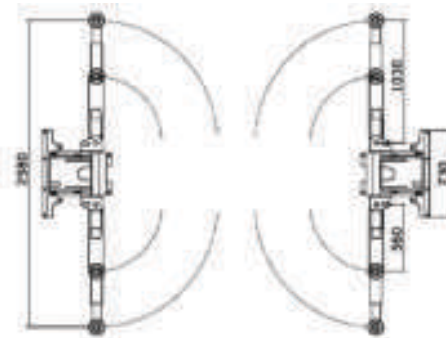



MACACO DE CENTRO
PNEUMÁTICO - Z37

€ 2.100



ELEVADORES DE COLUNAS

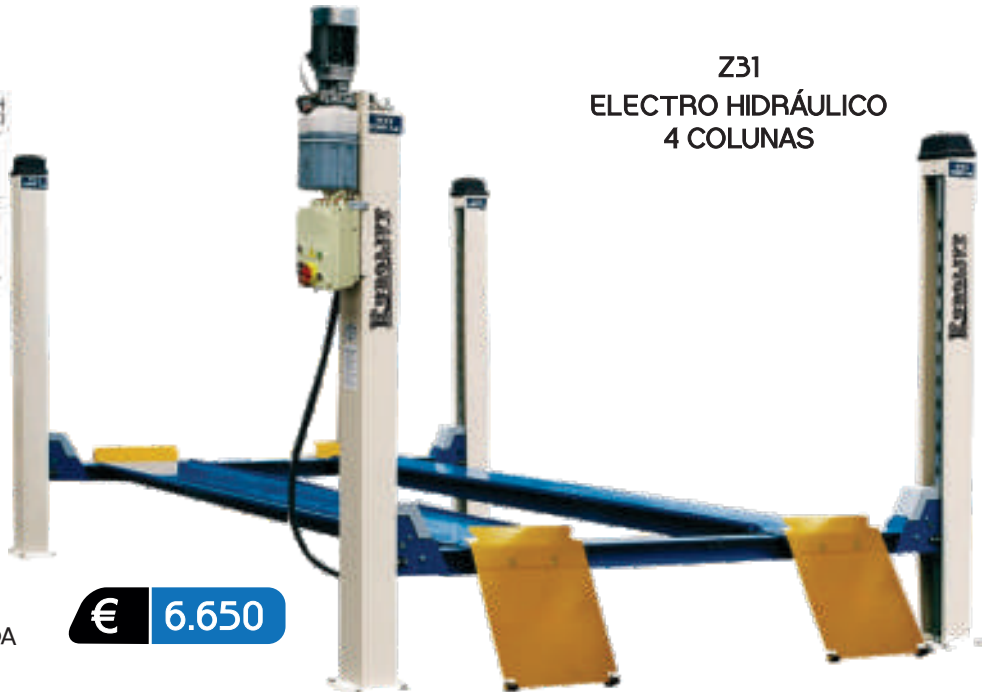
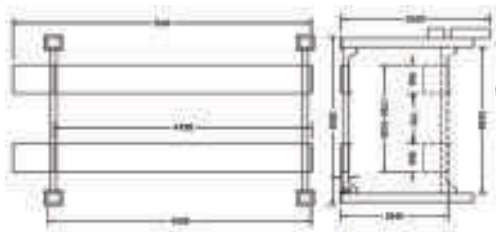

Z31
ELECTRO HIDRÁULICO
4 COLUNAS

CAPACIDADE - 4200 KG
MOTOR - 3 KW - 4 HP
380 V - 50/60 HZ
TEMPO DE SUBIDA m/S - 0.035
TEMPO DESCIDA m/S - 0.035
VÁLVULA DE SEGURANÇA
VÁLVULA DE CONTROLO DE DESCIDA

€ 6.650



ELEVADOR 4 COLUNAS INDEPENDENTES

MCL 55M.4S

CAPACIDADE - 22 TON - 4X5.5 TON
MOTOR - 1.6 KW
SISTEMA DE NIVELAMENTO AUTO-ELÉTRICO
TEMPO DE SUBIDA m/S - 0.035
TEMPO DESCIDA m/S - 0.035
VÁLVULA DE SEGURANÇA
VÁLVULA DE CONTROLO DE DESCIDA

€ 20.300

MCL 75 4S

CAPACIDADE - 30 TON - 4 x 7.5 TON

€ 22.600

MCL 85 4S

CAPACIDADE - 34 TON - 4 x 8.5 TON

€ 24.500



DISPONÍVEL KIT ADAPTADOR PARA RODAS 700-500 / 800-700 / 900-800

ELEVADORES ELECTROHIDRÁULICOS

**ELEVADOR
ELECTROHIDRÁULICO 4 TON**

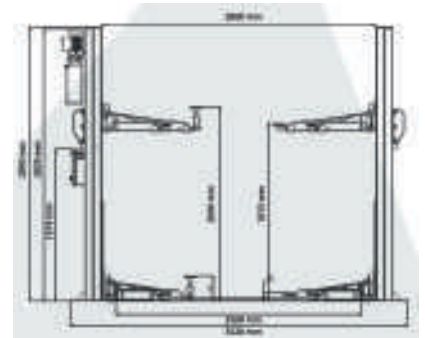
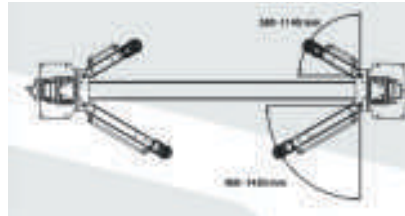

KN3240A
4 TON - 400V

€ 3.050

CAPACIDADE - 4000 KG
ALTURA DE ELEVÇÃO 1815 MM
TEMPO DE SUBIDA < 50 S
POTENCIA DO MOTOR 2.2 kW
ALTURA TOTAL 2845 MM
PESO 610 KG
ESPESSURA DA COLUNA 4.5 MM
QUADRO ELÉTRICO COM DOIS
DIFERENCIAIS DE SEGURANÇA
BRAÇOS EXTENSÍVEIS EM 3 PEÇAS
VALVULA MANUAL DE EMERGENÇA
TRANCAS AUTOMÁTICAS

KN3240A
4 TON - 230V

€ 3.150

KNSB002
SEMI BASE
1500X100 MM
PREÇO CONJUNTO

€ 320



KN4045
BASE EM H

€ 690

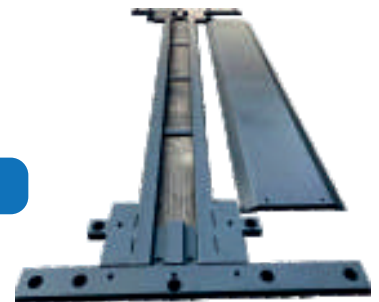

KN3245PSX
4.5 TON

€ 3.940

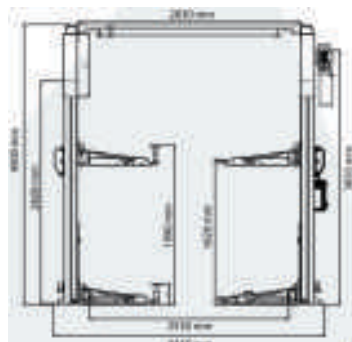
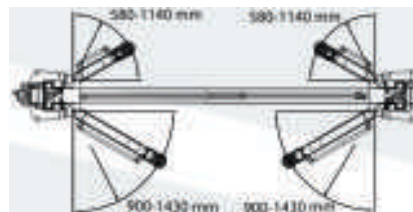

COLUNAS EM AÇO DE
5 MM DE ESPESSURA
CABO SINCRONIZADOR DE 12 MM
QUADRO COM 2 DIF. DE SEGURANÇA
TEMPO DE SUBIDA/DESCIDA < 50 S
ALTURA 4500 MM
BRAÇOS 580-1140 MM
BRAÇOS 900-1430 MM
PESO 720 KG
2830MM ENTRE COLUNAS
LIMITADOR DE SUBIDA

ELEVADORES ELECTROHIDRÁULICOS



ELEVADOR 2 COLUNAS
PARA VEÍCULOS DE CARGA

CAPACIDADE
6000 KG

KN3260PSX

€ 6.700

Königstein

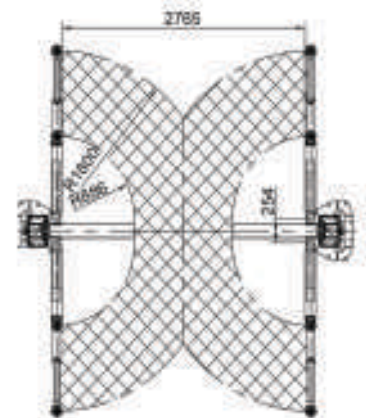
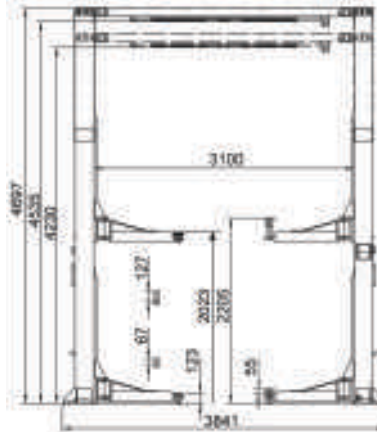

ELEVADOR AJUSTÁVEL EM ALTURA
SEGURANÇAS ELECTROMAGNÉTICAS
BRAÇOS EXTENSÍVEIS EM 3 PEÇAS
BARRA SUPERIOR DE FIM DE CURSO
TACOS DE 67 MM E 127 MM INCLUÍDOS
ALTURA MÍNIMA - 123 MM
TEMPO DE ELEVAÇÃO - 50 S
PESO - 1100 KG



ELEVADOR DE 4 COLUNAS

ELEVADOR DE POUCA MANUTENÇÃO
TRANSMISSÃO COM CILINDRO E CABOS
TRANCAS PNEUMÁTICAS
LARGURA AJUSTÁVEL ENTRE PLATAFORMAS
PESO 1200 KG
POTENCIA 2.2 KW
TEMPO DE SUBIDA < 60 S

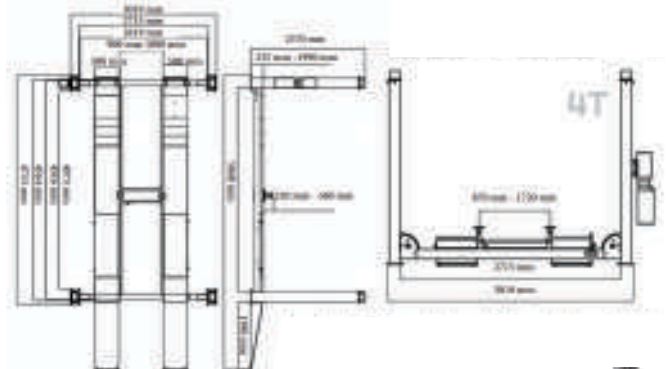

ELEVADOR IDEAL PARA ALINHAMENTO

DISPONÍVEL EM
4 E 5 TONELADAS

KN3440A
4 TON

€ 7.300

KN3450A
5 TON

€ 8.480

KNR306
3 TON

€ 1.380



MACACO CENTRAL OPCIONAL

ELEVADORES ELECTROHIDRÁULICOS

ELEVADOR DE TESOURA ELECTROHIDRÁULICO PARA ALINHAMENTO



VERSÃO DE
ENCASTRAR

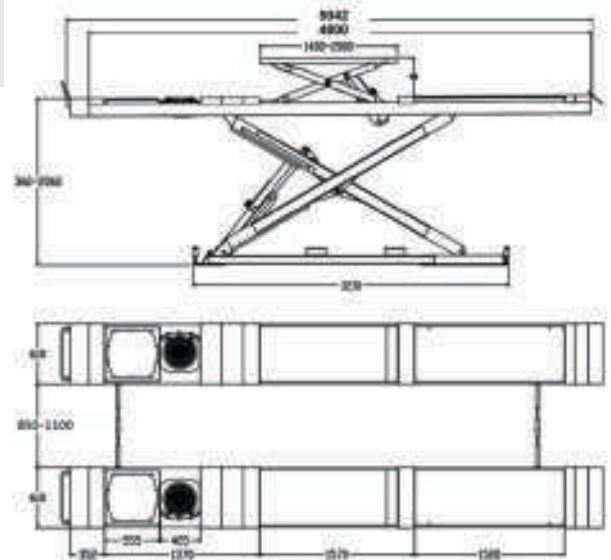

RAMPAS OPCIONAIS PARA
INSTALAÇÃO À SUPERFÍCIE

KN-R10 € 1.500

KN3642DT
VERSÃO 4.2 TON € 14.990

CAPACIDADE - 4200 KG
TEMPO DE ELEVAÇÃO - 60 S
COMP. DA PLATAFORMA 4845 MM
PERFIL MÍNIMO 75 MM
POTÊNCIA 2.2 KW
COMPRIMENTO 5.5 MTS
ESPAÇO PARA PLACAS DE ALINHAMENTO
SINCRONIZAÇÃO E NIVELAMENTO ELÉCTRICO
SISTEMA DE SEGURANÇA MECÂNICO
TRANCAS PNEUMÁTICAS



ALTURA MÍNIMA DE 330 MM
IDEAL PARA INSTALAÇÃO AO NÍVEL DO SOLO

KN3655DTECO

€ 18.990

CAPACIDADE - 5500 KG
IDEAL PARA VEÍCULOS LARGOS
SUBIDA ATÉ 1850 MM
MACACOS AUXILIARES SOBEM 450MM
MOTOR 2.2 KW
TRIFÁSICO 400V

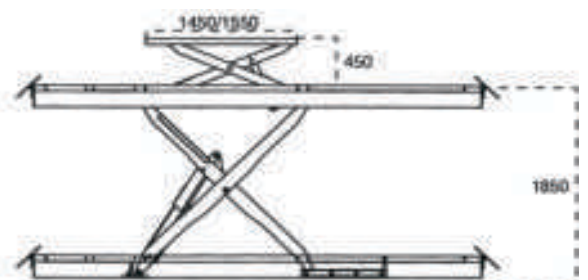
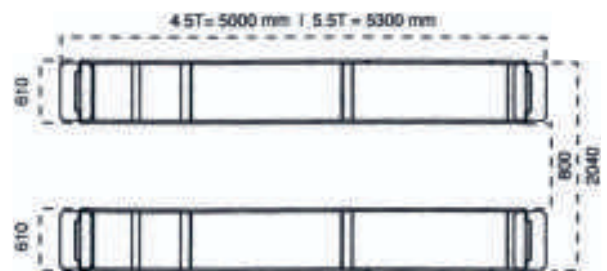

ELEVADORES DIVERSOS

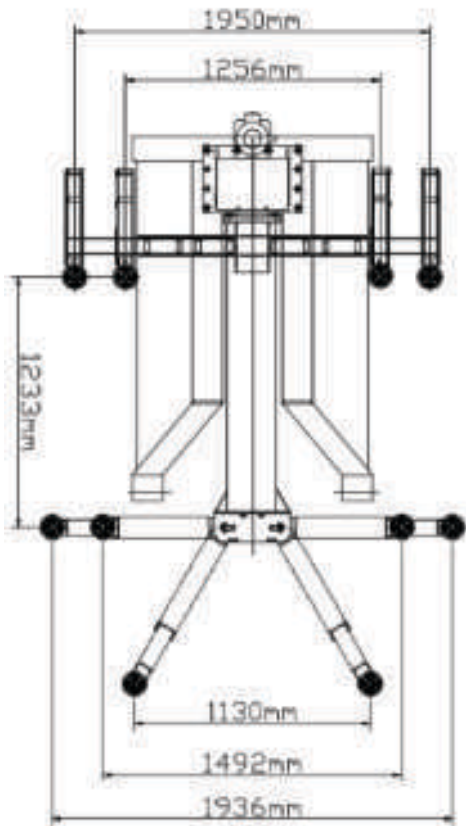

ELEVADOR DE UMA COLUNA

CAPACIDADE - 2500 KG
 ALTURA MÁX - 1825 MM
 TEMPO DE SUBIDA - 40 S
 ALTURA MÍNIMA - 100MM
 POTÊNCIA - 2.2 kW 3 Hp
 PESO - 770 KG
 BRAÇOS AMOVÍVEIS
 BORRACHAS COM REGULAÇÃO
 SEGURANÇA MECÂNICA PARA
 PROTECÇÃO DA HIDRÁULICA
 ROBUSTO PARA UMA VIDA LONGA



KN3125PA € 4.980



ELEVADOR DE TESOURA
 ELECTROHIDRÁULICO PARA MOTOS

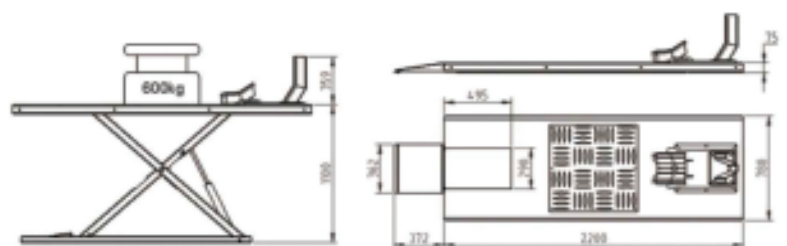

CAPACIDADE - 600 KG
 ALTURA DE ELEVAÇÃO - 1100 MM
 PERFIL MÍNIMO 75 MM
 TRANCA MECÂNICA
 DUPLO CILINDRO
 GRAMPO DA RODA ZINCADO
 RAMPA MÓVEL

KN3606MT

€ 2.990

ELEVADORES DE TESOURA

ELEVADOR DE TESOURA ELECTRO HIDRÁULICO



4 PISTONS - STD 7230 B

- CAPACIDADE - 3000 KG
- TEMPO DE SUBIDA - 60 SEG
- ALTURA DE ELEVAÇÃO - 1900 MM
- PERFIL MÍNIMO 112 MM
- TRANCA MECÂNICA
- DUPLO CILINDRO
- COM ACRESCENTOS NA PLATAFORMA

400 V € 4.990

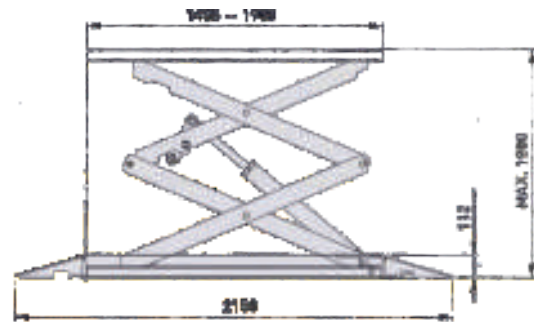

ELEVADOR DE ESTEIRA ELECTRO HIDRÁULICO

- TESOURA DUPLA - 3000 KG
- KIT DE DESLOCAMENTO
- NÃO NECESSITA DE FIXAÇÃO AO SOLO
- RAMPAS COM FIXAÇÃO PARA BASE

STD 7530

€ 3.990

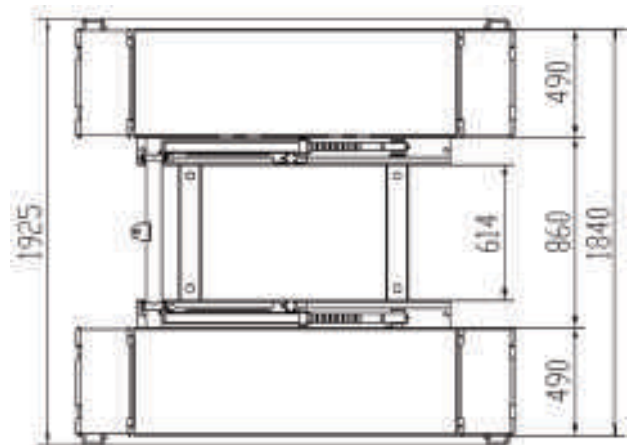
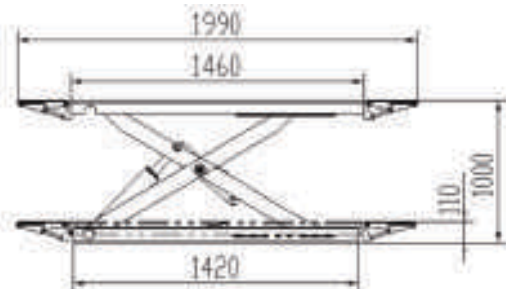

ELEVADOR E LINHA DE PRÉ INSPEÇÃO

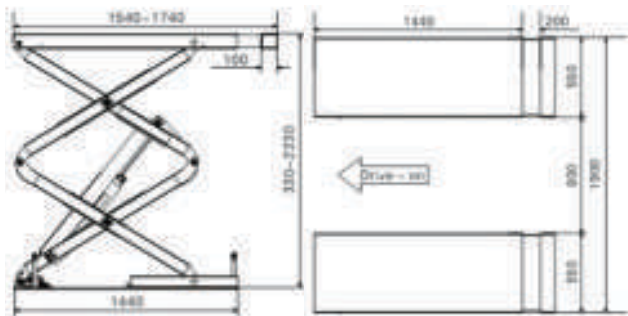

CAPACIDADE - 3500 KG
 ALTURA MÍNIMA - 330 MM
 ALTURA MÁXIMA - 2230 MM
 TEMPO DE SUBIDA - 60 S
 400 V
 AZUL (RAL5015)
 TRAVÃO AUTOMÁTICO EM
 CASO DE FALTA DE PRESSÃO

STD 7335

€ 5.250



LINHA DE INSPEÇÃO AUTOMÓVEL

BANCO DE TESTE DE TRAVÕES RBT3500 XS

TESTE DE TRAVÕES PARA CARROS, QUADRICICLOS
 E MOTOCÍCLOS ATÉ 3.5 TON
 SOFTWARE DE TESTE PARA WINDOWS
 MÁXIMO PESO POR EIXO - 2500 KG
 MOTOR POWER: 2 X 4 KW (5,5 KM/H TEST SPEED)
 ROLOS REVESTIDOS, SISTEMA DE BALANÇA,
 SUSPENSÃO E TESTE DERRAPAGEM.
 DIMENSÕES - 2330 X 650 X 275 MM

TESTE DE SUSPENSÃO - STL

COM SISTEMA DE CÁLCULO EUSAMA
 O SOFTWARE VERIFICA OS PARÂMETROS:
 MÓDULO DE TESTE DE SUSPENSÃO DE VIBRAÇÃO
 SISTEMA DE PONDERAÇÃO EMBUTIDO
 MEDIÇÃO AUTOMÁTICA DE PESO
 MÁXIMO PESO POR EIXO - 2000 KG
 DIMENSÕES - 2335 x 650 x 275 MM



RIPÓMETRO - TRZ

KIT DIR 2/4 WD +STL - KIT ALIMENTAÇÃO CONEXÃO PC
 PRATO DESLIZANTE GALVANIZADO
 VM 02 - CONTROLE REMOTO INFRAVERMELHO
 T100/GREY - CONSOLA C/SUPOORTE LCD
 KIT T100 + MULTIFICHAS + PC VMG
 WINDOWS, PC, MONITOR, RATO, TECLADO E IMPRESSORA

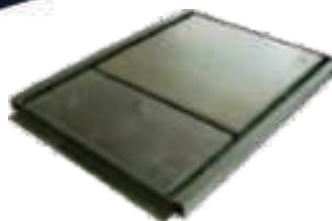

€ 19.900

PREÇO DO CONJUNTO



ELEVADORES ELECTROHIDRÁULICOS

ELEVADOR DUAS COLUNAS ELECTRO HIDRÁULICO

208I/55S.4

- MOTOR 3 KW - 4 HP
- CAPACIDADE - 5500 KG
- 4 BRAÇOS ARTICULADOS
- ALTURA DE ELEVAÇÃO ÚTIL 4930 MM
- SUBIR / DESCER - 35 S
- BESOIRO COM ALARME
- VÁLVULA DE SOBRECARGA

€ 16.790

EXTENSOR MAIOR DISPONÍVEL
SOB CONSULTA

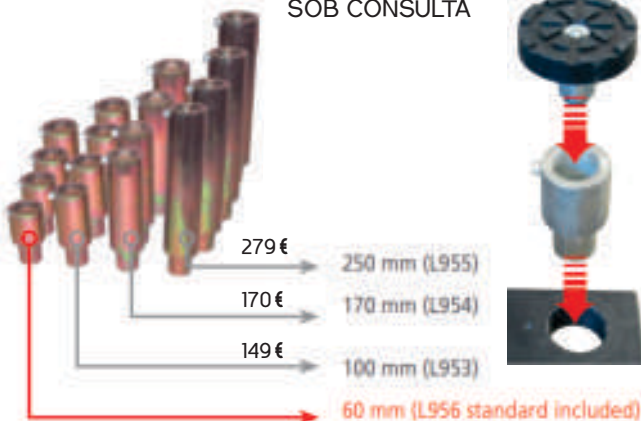

IDEAL PARA GRANDES VEÍCULOS

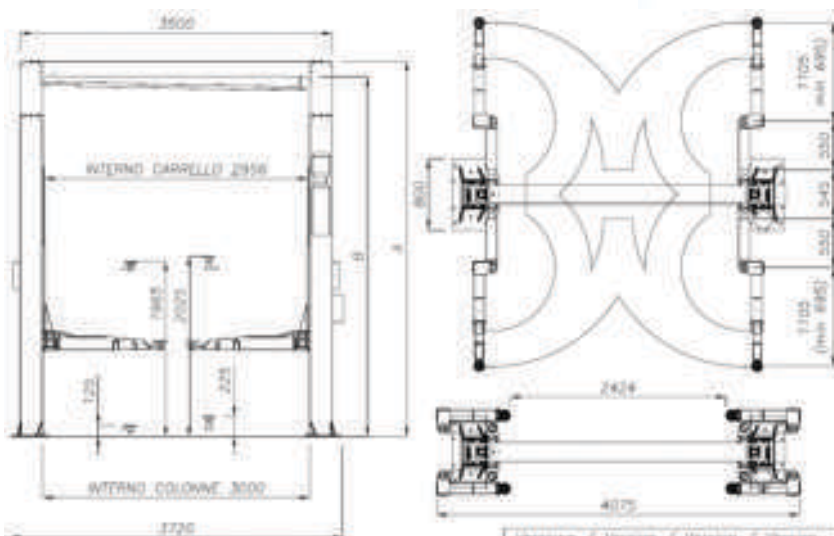

	Versione / Version	Version / Version
	208I/55S	208I/55S.4
A	4200 (3000+600)	5100 (3800+1500)
B	4030	4930

DISPONÍVEL MONOFÁSICO SOB CONSULTA

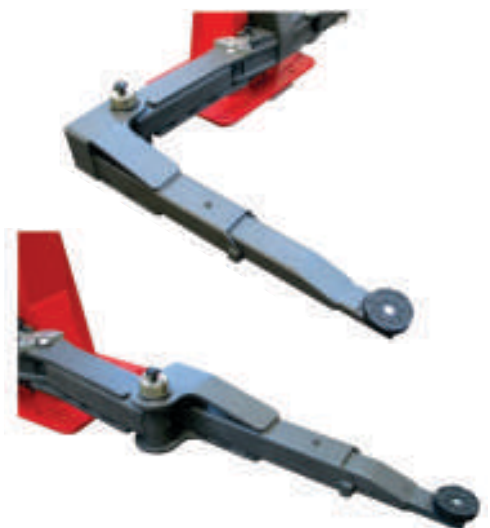

BANCOS DE FORÇA

MAXI BULL

BANCADA DE ENDIREITAMENTO RÁPIDO



COM RAMPAS
INCLUÍDAS

REPARAR RAPIDAMENTE PEQUENOS E MÉDIOS DANOS.
A FIRMEZA DO CHASSI PERMITE O POSICIONAMENTO DE QUALQUER TIPO DE VEICULO DE FORMA RÁPIDA E SIMPLES SEM O USO DE RAMPAS

POTENCIA DE ELEVAÇÃO - 3000 KG
ALTURA MINIMA DO SOLO - 140 MM
ALTURA MÁXIMA DO SOLO - 1312 MM
TEMPO DE SUBIDA - 60 SEGUNDOS
ALIMENTAÇÃO - 230 / 400 V - 50/60 HZ - 3 PH
PESO 1300 KG - 4 TORNOS UNIVERSAIS
BRAÇO DE TRAÇÃO COM ENCAIXE 360º

OPCIONAIS

KIT BMW
KIT MERCEDES
KIT HONDA / A ROVER



€ 16.800

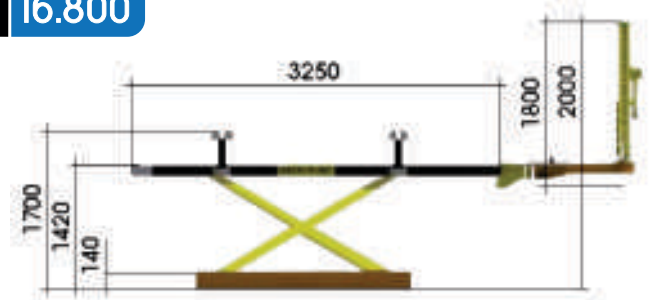

ÁREAS DE PREPARAÇÃO

AREA DE PREPARAÇÃO



ESTUDADA E PROJECTADA PARA REALIZAR OPERAÇÕES DE POLIMENTO,
LIXA E PREPARAÇÃO PARA PINTURA EM AMBIENTE LIMPO
LIVRE DE FUMO E POEIRAS.

BASE 6000 X 4000 MM
MOTOR 7.5 HP
COM RAMPAS

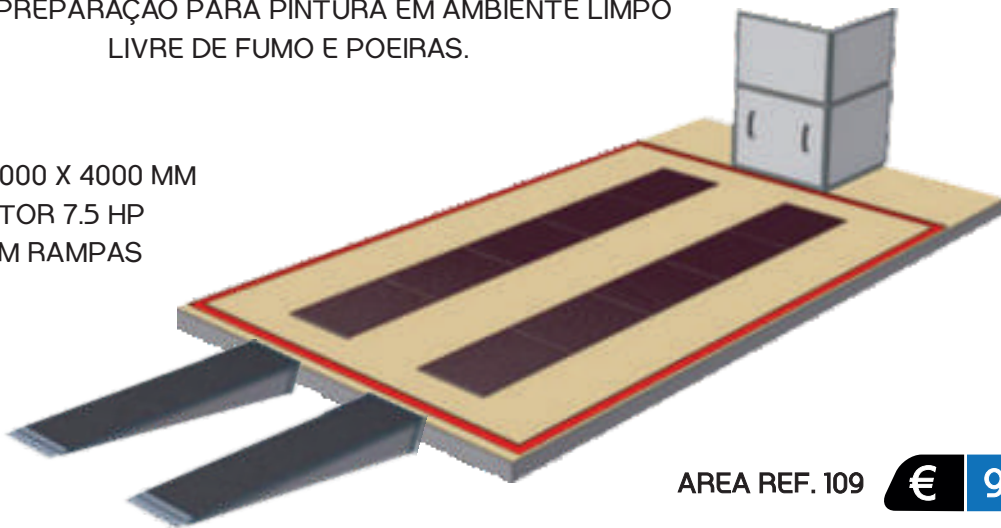

AREA REF. 109

€ 9.900



BOX DE TINTAS

ESTUDADA E PROJECTADA PARA A PREPARAÇÃO DE TINTAS
E MISTURAS, MESMO COM O OPERADOR DENTRO DA CABINE.
SERVE DE ARMAZÉM DE TINTAS E MISTURADORES.
EQUIPADA COM LAMPADA DE TECTO 4 NEON 36 WATT
VENTILADOR CENTRIFUGO
MOTOR ELECTRICO DE FUNCIONAMENTO DIRETO
PAINEL PARA CONTROLO DA CABINE



TINTO BOX
3X2 X 2.5/2.7

€ 4.450

TINTO BOX
4X2 X 2.5/2.7

€ 5.320



NÃO ESTÁ INCLuíDO OBRA CIVIL, ALIMENTAÇÃO ELÉCTRICA E PNEUMÁTICA, TUBAGENS DE EXAUSTÃO DO QUEIMADOR E DA EXTRAÇÃO



CABINES DE PINTURA

CABINE DE PINTURA - GL1 - TERMOMECCANICA



PRODUTO DE QUALIDADE DE TOPO PARA CLIENTES EXIGENTES
COM BASE E RAMPAS - EXTRAÇÃO DE DUAS LINHAS
COMP - 7 MT :: LARGURA - 4 MT :: ALTURA 2.80 MT
FILTRO DE TETO E ILUMINAÇÃO SUPERIOR EM NEONS
CALDEIRA EM AÇO INOX E QUEIMADOR DE GLP
CAUDAL MÁXIMO 18.000 / 20.00 MC / H - MOTOR 10 HP
POTÊNCIA QUEIMADORES - 180.000 KCAL / H

€ 30.900



NÃO ESTÁ INCLUÍDO OBRA CIVIL, ALIMENTAÇÃO ELÉCTRICA E PNEUMÁTICA, TUBAGENS DE EXAUSTÃO DO QUEIMADOR E DA EXTRAÇÃO

LIMPEZA DE PISTOLAS DE PINTURA

EQUIPAMENTO DE LIMPEZA DE PISTOLAS DE PINTURA



SL 427

TANQUE DE ÁGUA - 50 LT
PESO - 114 KG
DIMENSÃO - 990 X 690 X 1490
PNEUMÁTICA - 6 A 10 BAR
EXAUSTÃO - 150 MM DIAMETRO

€ 4.490

COMBINADA- LAVAGEM DE TINTA À BASE DE ÁGUA E À BASE DE SOLVENTES.
ZONA DE LIMPEZA COM EXAUSTÃO AUTOMÁTICA
LAVAGEM AUTOMÁTICA COM BOMBA DIAFRAGMA DE LIQUIDO RECICLADO.
BOMBA VENTURI E NEBULIZADOR PARA LAVAGEM FINAL COM ÁGUA
KIT DE SEPARAÇÃO DE ÁGUA E TINTA
BOMBA PARA DILUENTE LIMPO.
100% INOX



EQUIPAMENTO DE LIMPEZA DE PISTOLAS DE PINTURA



PARA LAVAGEM MANUAL PARA PINTURA À BASE ÁGUA
BOMBA VENTURI PARA RECICLAGEM LIQUIDO
LAVAGEM FINAL COM PULVERIZADOR UTILIZANDO ÁGUA LIMPA
PISTOLA DE SOPRO PARA A SECAGEM FINAL
KIT DE SEPARAÇÃO ÁGUA-PINTURA INCLUÍDO
100% INOX

SL 16

TANQUE DE ÁGUA - 50 LT
PESO - 50 KG
DIMENSÃO - 490 X 690 X 1490
PNEUMÁTICA - 6 A 10 BAR

€ 1.487



ACESSÓRIOS DE OFICINA



EMBALAGEM
5 LITROS

RE - 5

€ 80

DETERGENTE CONCENTRADO DILUÍVEL EM ÁGUA
NOVA FORMULA COM POUCA ESPUMA
USADO A FRIO:
MELHORA A LAVAGEM MESMO EM TINTA SECA
USADO A QUENTE:
REDUZ PARA METADE O TEMPO DE LAVAGEM E PERMITE
UMA LIMPEZA COMPLETA MESMO EM TINTA SECA
MANTÉM A BOMBA, MANGUEIRA E BICOS SEMPRE LIMPOS
É REUTILIZÁVEL APÓS COAGULAÇÃO
5-15% DE DILUIÇÃO EM ÁGUA



KRWPR20F
PRENSA ACIONAMENTO PEDAL
20 TON
MIN - 180 | MAX - 955
LARGURA TRABALHO - 550

€ 432

KRWPR10F
PRENSA ACIONAMENTO PEDAL
10 TON
MIN - 180 | MAX - 910
LARGURA TRABALHO - 454

€ 340



KRWJS2

PREGUIÇA 2 UNIDADES
2 TON
MIN - 273 | MAX - 430
PESO - 5 KG



€ 28

KRWTJ5

MACACO FOSSAS 500 KG
DESCIDA CONTROLADA
CILINDRO CROMADO
BOMBA A PEDAL
MIN - 1000 | MAX 1900

€ 180



ACESSÓRIOS DE OFICINA



PTJ 05-048
5.5 TON € 210

MIN: 310 MM - MAX: 480 MM



PTJ 05-073
5.5 TON € 240

MIN: 445 MM - MAX: 730 MM



PTJ 05-120
5.5 TON € 325

MIN: 695 MM - MAX: 1200 MM

PTJ 10-048
10 TON € 268

MIN: 310 MM - MAX: 480 MM

PTJ 10-073
10 TON € 325

MIN: 445 MM - MAX: 730 MM

PTJ 10-120
10 TON € 462

MIN: 695 MM - MAX: 1200 MM

PTJ 20-048
20 TON € 312

MIN: 310 MM - MAX: 480 MM

PTJ 20-073
20 TON € 362

MIN: 445 MM - MAX: 730 MM

PTJ 20-120
20 TON € 487

MIN: 695 MM - MAX: 1200 MM

protools
GARAGE EQUIPMENT

PTJ60123



3 PISTONS DESMULTIPLICAÇÃO
CAPACIDADE - 60/30/15 TON
ALTURA MINIMA - 120 MM
ALTURA MAXIMA - 255 MM
8 A 10 BAR - 50 KG
600 NL/MIN - CONSUMO DE AR
EXTRA REBAIXADO
ESPECIAL AUTOCARROS

€ 2.520

PTJ60222



2 PISTONS DESMULTIPLICAÇÃO
CAPACIDADE - 60/ 30 TON
ALTURA MINIMA - 220 MM
ALTURA MAXIMA - 450 MM
8 A 10 BAR - 71 KG
600 NL/MIN - CONSUMO DE AR

€ 2.420

protools
GARAGE EQUIPMENT

PTJ40152



3 PISTONS DESMULTIPLICAÇÃO
CAPACIDADE - 40/ 20 TON
ALTURA MINIMA - 150 MM
ALTURA MAXIMA - 300 MM
8 A 10 BAR - 39 KG

€ 1.670

PTJ4017M



2 PISTONS DESMULTIPLICAÇÃO
CAPACIDADE - 30/ 15 TON
ALTURA MINIMA - 170 MM
ALTURA MAXIMA - 341 MM
8 A 10 BAR - 39 KG

€ 1.560



ACESSÓRIOS DE OFICINA

05.084.26

MACACO DUPLO PISTON
5 TON
MIN - 100 MM | MAX - 533 MM
PESO - 44 KG



€ 285



05.084.02L

MACACO DUPLO PISTON
BAIXO PERFIL
3 TON
MIN - 80 MM | MAX - 495 MM
PESO - 37 KG



€ 197



SUPORE FRONTAL
PARA MOTORES

6 RODAS PARA MAIOR ESTABILIDADE
ALTURA DO SOLO: 800 MM
PRATO DE FIXAÇÃO: 250X150X12 MM
CAPACIDADE 900 KG - 36 KG



05.085.12

€ 168



GRUA
DESMONTÁVEL

05.084-08 COMBI

CAPACIDADE: 1 TON
MEDIDAS: 1620X930X1600MM
EMBALAGEM: 800X860X1600MM
76 KG

€ 330



MACACOS DE GARRAFA



KRWBJ2
2 TON

€ 15

KRWBJ6
6 TON

€ 24

KRWBJ10
10 TON

€ 33

KRWBJ12
12 TON

€ 39



	MOD.	ALTURA MÍNIMA	SOBE	FUSO
05.084.16	20 TONS	235	145	60
05.084.15	32 TONS	255	150	--

05.084.16
20 TON

€ 54,5

05.084.15
32 TON

€ 105,4

ACESSÓRIOS DE OFICINA



SUPORE PARA
MOTORES

FG748/0.5T

€ 139

CARRO SUPORE
DE PEÇAS

PARA BATE-CHAPAS E
PINTURA AUTOMÓVEL

53125

€ 310



SISTEMA DE HIGIENIZAÇÃO DE ESPAÇOS E VIATURAS



3 PASSOS:

1º - EMISSÃO DE OZONO CONTROLADO
ATRAVÉS DE SENSOR DE SATURAÇÃO

2º - HIGIENIZAÇÃO TEMPORIZADA DE OZONO

3º - RECONVERSÃO AUTOMÁTICA DE OZONO EM OXIGÉNIO

IMPRIME TALÃO DE DATA E HORA, DURAÇÃO

E VALOR DA QUANTIDADE DE OZONO PRODUZIDO

FILTROS HEPA, FILTRO DE CARVÃO ATIVO

FG702/OZ3.5 - 12 V / 230 V € 699 3.5 G/H

FG702/OZ5 - 230 V € 749 5.0 G/H

FG702/OZ10.0 - 230 V € 799 10 G/H

ÚNICA NO MERCADO QUE FAZ TODOS OS PASSOS DA
HIGIENIZAÇÃO. NO FIM DA HIGIENIZAÇÃO TRANSFORMA O OZONO EM OXIGÉNIO PURO
PODENDO O LOCAL HIGIENIZADO SER IMEDIATAMENTE UTILIZADO.



CILINDRO 19 LITROS
VÁLVULA DE SEGURANÇA
IDEAL PARA TUBELESS ATÉ 24.5"
MANÓMETRO Ø50 MM
DIMENSÕES EMBALAGEM: 46X40X31 - 14 KG

03.000.52 € 199



CARRO DE TRANSPORTE
PARA PNEUS DE PESADOS
AJUSTÁVEL
CAPACIDADE: 250 KG
PARA PNEUS DE 6.5' A 22.5'

05.088.130 € 250



ACESSÓRIOS DE OFICINA

IDEAL PARA CARROS ELÉCTRICOS

PLATAFORMA DE ELEVAÇÃO HIDRÁULICA
PROJECTADA PARA MONTAR E DESMONTAR
MOTORES, CAIXAS E BATERIAS DE LÍTIO
DE AUTOMÓVEIS HÍBRIDOS E ELÉCTRICOS.
MÁX 180 CM - MIN 50 CM - CAPACIDADE - 1000 KG
DIMENSÃO DA PLATAFORMA - 130 X 80 X 7
PESO 300 KG



05.085.16

€ 2.590



PLATAFORMA ELEVATÓRIA ATÉ 1800 MM

1.000 KG CAPACIDADE



PRENSAS HIDRÁULICAS COM PISTON MÓVEL

PRENSA HIDRÁULICA COM PISTOM MÓVEL
VÁLVULA DE SEGURANÇA DE SOBRECARGA
RETORNO AUTOMÁTICO DO CILINDRO
MANÓMETRO DE PRESSÃO
PISTÃO DE AÇO TRATADO
VÁLVULA LIMITADORA



ME25M - 25 TON - 1 VELOCIDADE

€ 1.090

ME35M - 35 TON - 1 VELOCIDADE

€ 1.210



MED35M - 35 TON - 2 VELOCIDADES

€ 1.499

MED50M - 50 TON - 2 VELOCIDADES

€ 2.299

ACESSÓRIOS DE OFICINA



DECAPAGEM A AREIA INDUSTRIAL

05.075.16

- ABERTURA SUPERIOR
- ASPIRADOR COM CICLONE
- 420 LITROS
- COMANDO PEDAL
- CICLONE PERMITE UMA EXTRAÇÃO DO PÓ E DA AREIA EFICAZ
- ILUMINAÇÃO INTERNA
- INCLUI: 4 CERÂMICAS
- 1 PISTOLA INDUSTRIAL
- 2 LAMPADAS HALOGENIO
- 5 PELICULAS DE PROTEÇÃO DA LUZ
- 2 ROLOS DE VEDAÇÃO
- 1 ROLO TEFLOM E SEPARADOR DE ÁGUA

€ **1.720**



DIMENSÃO EXTERNA - 1210X610X1700 MM
 DIMENSÃO BOX - 1200X600X370/600 MM
 DIMENSÃO PORTA - 1000X570 MM
 BICO 6.7 MM

PRESSÃO DE TRABALHO ENTRE 3.5 E 5.5 BAR
 CONSUMO DE AR 170 LT/MIN



220L















DECAPAGEM A AREIA

05.075.10

- PRESSÃO DE TRABALHO ENTRE 2.8 E 5.6 BAR
- CONSUMO DE AR - 450/550 LT/MIN
- DIMENSÃO BOX - 596X838X625 MM
- PREPARADO PARA ASPIRAÇÃO (NÃO INCLUÍDA)
- INLCUI:
- PAR DE LUVAS
- CONJUNTO DE BICOS
- PISTOLA DE JACTO DE AREIA

€ **480**

SPARE PARTS	 Cod. 05.075.16	 Cod. 05.075.10	 Cod. 05.075.17	 Cod. 05.075.18
BOCAIS PARA PISTOLA	 Cod. 05.075.22	 Cod. 05.075.11	 Cod. 05.075.26	 Cod. 05.075.24
PISTOLA DECAPAGEM	 Cod. 05.075.23	 Cod. 05.075.13	 Cod. 05.075.28	 Cod. 05.075.29 <i>Foto indicativa / Indicative picture</i>
PAR DE LUVAS	 Cod. 05.075.12	 Cod. 05.075.12		

**PREÇOS DOS ACESSÓRIOS
SOB CONSULTA**



NEXION

AUTOMOTIVE SOLUTIONS

MÁQUINAS PARA PNEUS

HELPER HSA 21 - 8-11900262

€ 450

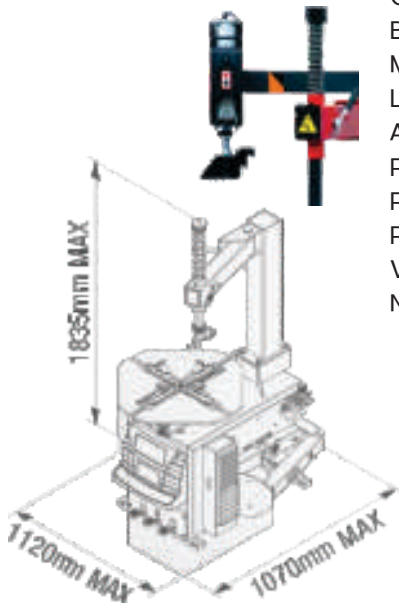

STEPLINE 2300 - ESPECIAL MOTAS

GRAMPO EXTERIOR - 10" - 21"
BRAÇO INTERNO - 12" - 23"
MÁX. DIÂMETRO DA RODA - 960 mm
LARGURA DO PNEU - 3" A 12"
ABERTURA DE DISJUNTORES - 320 mm
PODER QUEBRA O ROLAMENTO - 2500 N
PRESSÃO DO AR DE TRABALHO - 8 - 10 bar
POTÊNCIA DO MOTOR (PEDAL DUAS VELOCIDADES) - 0,75 kW - 1,1 kW
VELOCIDADE DE ROTAÇÃO DO CHUCK - 7 rpm
NÍVEL DE RUÍDO EM EXECUÇÃO: <70 dB

SEMI AUTOMÁTICA
0-11901512/16 € 1.490

KIT GRAMPOS MOTOBIKE
C-M-0200000A € 139
(6-25") 4 pcs



OPÇÃO MONOFÁSICO ACRESCE 130 EUROS



GRAMPO EXTERIOR - 10" - 21"
BRAÇO INTERNO - 12" - 23"
MÁX. DIÂMETRO DA RODA - 1040 mm
LARGURA DO PNEU - 3" A 12"
ABERTURA DE DISJUNTORES - 320 mm
PODER QUEBRA O ROLAMENTO - 2800 N
PRESSÃO DO AR DE TRABALHO - 8 - 10 bar
POTÊNCIA DO MOTOR (PEDAL DUAS VELOCIDADES) - 0,75 kW - 1,1 kW
VELOCIDADE DE ROTAÇÃO DO CHUCK - 7 RPM - 2V 6,5 - 13 RPM
NÍVEL DE RUÍDO EM EXECUÇÃO: <70 dB

STEPLINE 3500 2V

0-11901421/16

€ 1.950

HELPER HTB 21 - 8-11900261

€ 640

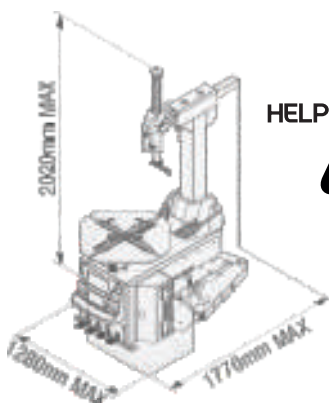

OPCIONAL
HELPER HTB
21 - 8-11900261

OPÇÃO MONOFÁSICO ACRESCE 130 EUROS

MÁQUINAS PARA PNEUS



STEPLINE 4000 TI 2V

**COM INFLATOR
INCORPORADO**

GRAMPO EXTERIOR - 11" - 24"
BRAÇO INTERNO - 13" - 26"
MÁX. DIÂMETRO DA RODA - 1100 mm
LARGURA DO PNEU - 3" A 14"
ABERTURA DAS MORSAS - 380 mm
PODER QUEBRA O ROLAMENTO - 2800 N
PRESSÃO DO AR DE TRABALHO - 8 - 10 bar
POTÊNCIA DO MOTOR (PEDAL DUAS VELOCIDADES) - 0,85 kW - 1,1 kW
VELOCIDADE DE ROTAÇÃO DO CHUCK - 7 RPM - 2V 6,5 - 13 RPM
NÍVEL DE RUÍDO EM EXECUÇÃO: <70 dB
BRAÇO DE APOIO OPCIONAL NÃO INCLUIDO



HELPER HTB 24 - 8-11900260

€ **690**



OPÇÃO MONOFÁSICO ACRESCE 130 EUROS



001901331/16

€ **2.960**

STEPLINE 4000 2V



RECOMENDADO PELA



GRAMPO EXTERIOR - 11" - 24"
BRAÇO INTERNO - 13" - 26"
MÁX. DIÂMETRO DA RODA - 1100 mm (42")
LARGURA DO PNEU - 3" A 14.5"
ABERTURA DAS MORSAS - 380 mm
PODER QUEBRA O ROLAMENTO - 15000 N
PRESSÃO DO AR DE TRABALHO - 8 - 10 bar
PEDAL DUAS VELOCIDADES
NÍVEL DE RUÍDO EM EXECUÇÃO: <70 dB



**COM BRAÇO HELPER
HTB24
8-11100200**

€ **690**

INCLUI ACESSÓRIOS



STEPLINE4000 € **2.490**

OPÇÃO MONOFÁSICO ACRESCE 130 EUROS
0-11901321/16

NEXION



TECO 480 TOP TI LEVERLESS

CAPACIDADE DE FIXAÇÃO - 10 " - 27"
 FIXAÇÃO EXTERNA - 10 " - 24 "
 APERTO INTERNO - 13 " - 27 "
 DIÂMETRO MÁX. DA RODA - 1040 mm - 41"
 LARGURA MÁX. DA RODA - 14 "
 FORÇA DO BALÃO - 2.900 KGF
 VELOCIDADE DE ROTAÇÃO - 8.5 RPM
 PRESSÃO DO AR DE TRABALHO - 8 - 10 bar
 MOTOR MODELO TRIFÁSICO - 0.8-1.1 KW
 MOTOR MONOFÁSICO - 0.75 KW (1.0 HP)



DIMENSÕES
 ALTURA - MÁX 1170 MM
 LARGURA - MÁX 1450 MM

0-1163349906/6

AUTOMÁTICA

€ 8.900

ACESSÓRIOS INCLUÍDOS

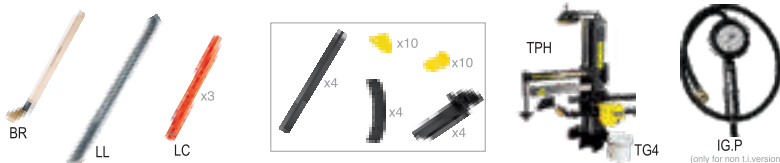

INCLUÍDO BRAÇO DE APOIO TP4
 OPÇÃO MONOFÁSICO ACRESCE 360 EUROS

OPCIONAIS
 PLS2 - ELEVADOR PNEUMÁTICO
 60 KG

€ 650



INCLUI ACESSÓRIOS

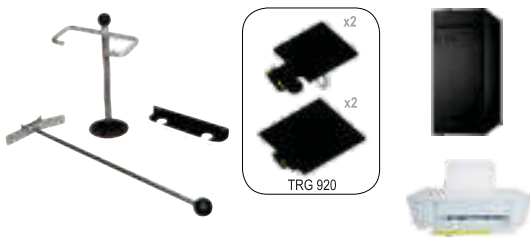

TECO 920

NEW



TECNOLOGIA DE 2 CÂMARAS DIGITAIS DE ALTA RESOLUÇÃO
 4 ALVOS VISUAIS ANTICHOQUE
 4 GARRAS DE FIXAÇÃO DE 11 " A 26 "
 BANCO DE DADOS COM MAIS DE 40.000 VEÍCULOS
 EQUIPADO COM PC INTEL
 SISTEMA OPERACIONAL WINDOWS 10 PRO
 PRECISÃO DE ALINHAMENTO - 0.01°
 LINGUAGEM EM PORTUGUÊS
 IMPRESSORA E MONITOR INCLUÍDOS.

FULL PACK 2



ALTURA 2918
 LARGURA 2878
 DA BASE AOS PRATOS DE 1800 A 3000
 CÂMARAS TRABALHA DE 500 A 2560 DE ALTURA

€ 11.900

MÁQUINAS PARA PNEUS

NEXION

AUTOMOTIVE EQUIPMENT



TECNOLOGIA DE 8 CÂMARAS DIGITAIS DE ALTA RESOLUÇÃO
ALVOS VISUAIS RESISTENTES A IMPACTOS,
SEM COMPONENTES ELECTRÓNICOS
CARRINHO MÓVEL NA ÁREA DE TRABALHO
BANCO DE DADOS COM MAIS DE 20.000 VEÍCULOS
EQUIPADO COM WINDOWS 7
SOFTWARE DE ANIMAÇÃO GRÁFICA INCLUÍDO
PRECISÃO DE ALINHAMENTO - 0.01°
IMPRESSORA E MONITOR INCLUÍDOS

INCLUI ACESSÓRIOS

€ 15.690

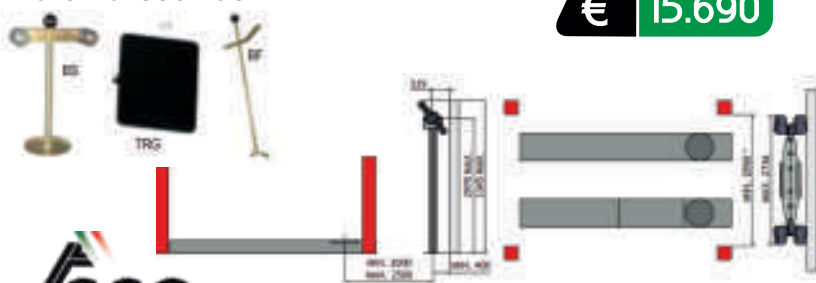

teco
AUTOMOTIVE EQUIPMENT

STEPLINE
6600 A



MÁQUINA DE CALIBRAR COM ENTRADA AUTOMÁTICA DE DADOS
TRAVÃO NO FINAL DO CICLO
RESGUARDO DE PROTECÇÃO INCLUÍDO
KIT DE CENTRALIZAÇÃO E BLOQUEIO INCLUÍDO
ATÉ 26"
MONOFÁSICA - 230 V

0-21900036/00

€ 2.260

ACESSÓRIOS INCLUÍDOS



LASER &
LED KIT

8-21100235

€ 299



teco
AUTOMOTIVE EQUIPMENT

STEPLINE
6800 A



COM MONITOR
GRÁFICOS ALTA RESOLUÇÃO
SOFTWARE ITALIANO
COM MONITOR
GRÁFICOS ALTA RESOLUÇÃO
SOFTWARE ITALIANO

0-21900038/00

€ 2.790

ACESSÓRIOS INCLUÍDOS



8-21900225

€ 650

OPCIONAIS:
FRU-SA D.40
FALANGE UNIVERSAL 5 PERNOS Ø90X210MM

LASER &
LED KIT

8-21100235

€ 299

KIT MOTOS
BUK BASIC

8-21900210

€ 590

EXTENSÃO
PRA5 - Ø14 MM

8-21900225

€ 72



NEXION

COM MONITOR INCLUÍDO
LANÇAMENTO MOTORIZADO DE BAIXO RUÍDO
MÁX. DIÂMETRO DA RODA - 28"
AJUSTÁVEL MANUALMENTE ATE 35"
LARGURA DO PNEU - 1.5" A 20"
PESO MÁXIMO DA RODA - 75 KG
DIÂMETRO DO EIXO - 40 MM
VELOCIDADE DE ROTAÇÃO - 90-130 RPM
PRECISÃO DE EQUILÍBRIO +/- 1 GR
TEMPO DE CICLO - 7 S
FONTE DE ALIMENTAÇÃO - 230 V - 50 / 60 HZ
PESO - 75 KG - PONTO A LASER INLCUIDO

0-21611710/16+8-211100238 **€ 4.280**

8-21100091

FRV-SAD D.40 Ø90X210MM

FALANGE UNIVERSAL PARA RODAS 3, 4 E 5 FUROS
(MODELOS TECO 600, 670 E 680)

€ 650

MÁQUINAS PARA PNEUS

TECO 680 COM KIT LASER & LIGHT



KIT SONAR TS

8-21100232 **€ 590**

MEDIÇÃO AUTOMÁTICA DA MEDIDA DA RODA



ENTRADA MANUAL DE PARÂMETROS
LANÇAMENTO MOTORIZADO DE BAIXO RUÍDO
MÁX. DIÂMETRO DA RODA - 28"
AJUSTÁVEL MANUALMENTE ATE 35"
LARGURA DO PNEU - 1.5" A 20"
PESO MÁXIMO DA RODA - 75 KG
DIÂMETRO DO EIXO - 40 MM
VELOCIDADE DE ROTAÇÃO - 90-130 RPM
PRECISÃO DE EQUILÍBRIO +/- 1 GR
TEMPO DE CICLO - 7 S
FONTE DE ALIMENTAÇÃO - 230 V - 50 / 60 HZ
PESO - 75 KG

0-21667010/16 **€ 2.990**



KIT LASER LIGHT
8-21100238

€ 310



KIT TS SONAR SENSOR
8-21100232

€ 590

TECO 670



8-211000911 - FRU-SAD D.40 Ø90X210MM
FALANGE UNIVERSAL PARA RODAS 3, 4 E 5 FUROS
(MODELOS TECO 600, 670 E 680)

€ 650



MEDIÇÃO AUTOMÁTICA DA MEDIDA DA RODA

MÁQUINAS PARA PNEUS

NEXION
AUTOMOTIVE EQUIPMENT

STEPLINE TECO 9300 TRUCK



EQUIPADO COM TODOS OS PROGRAMAS MAIS AVANÇADOS
7 PROGRAMAS DE CALIBRAGEM
DIÂMETRO MÁXIMO RODA - 1200 MM
PESO MÁXIMO DA RODA - 200 KG
DIÂMETRO MÁXIMO LEITURA DIGITAL 28" (MANUAL 35")
CALIBRAGEM RÁPIDA E FÁCIL
MULTIOPERADOR - 2 OPÇÕES DE TRABALHO
FUNÇÃO INSPECÇÃO VISUAL
MODO STAND-BY PARA POUPAR ENERGIA
8 A 12 BAR :: 1815 X 1381 MM
ACTUALIZAÇÃO DE SOFTWARE POR USB
220V

0-21900026/39

€ 4.690

ACESSÓRIOS INCLUIDOS



IDEAL PARA CAMIÕES, AUTOCARROS E CARROS LIGEIROS



STEPLINE 5400 TRUCK



ACESSÓRIOS INCLUIDOS



COM FIXAÇÃO DE 14" A 26"
PARA RODAS COM E SEM CÂMARA DE AR
DIÂMETRO MÁXIMO DA RODA - 1500 MM
LARGURA MÁXIMA DA RODA - 780 MM
FORÇA - 16000 N - DIÂMETRO MIN - 120 MM
PESO MÁXIMO DA RODA - 700 KG
400 V

0-121021101/16

€ 7.250



MÁQUINAS PARA PNEUS

ACESSÓRIOS INCLUIDOS



STEPLINE 5500 S



COM FIXAÇÃO DE 14" A 56"
 PARA RODAS COM E SEM CÂMARA DE AR
 DIÂMETRO MÁXIMO DA RODA - 2300 MM
 LARGURA MÁXIMA DA RODA - 1100 MM
 FORÇA - 28000 N - DIÂMETRO MIN - 100 MM
 PESO MÁXIMO DA RODA - 1500 KG
 400 V



0-12104301/16 € 10.590

FAZ DE 40" A 56" COM ADAPTADOR INCLUÍDO



ACESSÓRIOS INCLUIDOS

TECO 55 A

SEMI-AUTOMÁTICA



COM FIXAÇÃO DE 14" A 56"
 PARA RODAS COM E SEM CÂMARA DE AR
 DIÂMETRO MÁXIMO DA RODA - 2300 MM - 90.5"
 LARGURA MÁXIMA DA RODA - 1065 MM - 42"
 IDEAL PARA USO INTENSIVO E PROFISSIONAL
 400 V

0-12602601/16 € 13.900



INCLUI
OPCIONAL SE2

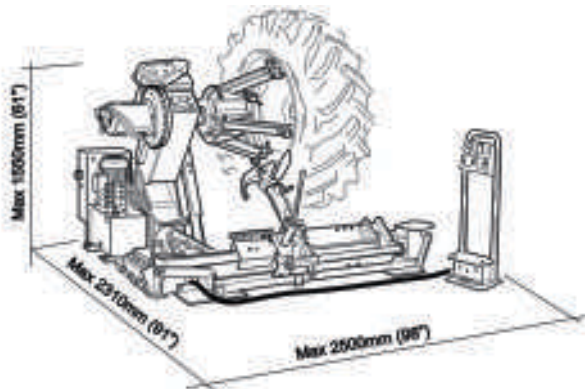

MÁQUINAS PARA PNEUS

Assetto compatibile con
Compatible with



ESPECIAL PESADOS

TECO 814 SPECIAL TRUCK

WINDOWS 10 MULTILINGUA
4 MEDIDORES COM 8 SENSORES CCD
TRANSMISSÃO DE DADOS WIRELESS - SEM FIO
BANCO DE DADOS COM MAIS DE 40.000 VEÍCULOS
PROGRAMA ESPECIAL PARA CAMIÕES ATÉ 4 EIXOS,
REBOQUES E SEMI REBOQUES (OPCIONAL)
COMPATÍVEL COM SISTEMA UNIVERSAL PROADAS



NEXION
AUTOMOTIVE SOLUTIONS

€ 12.900

ACESSÓRIOS INCLUIDOS

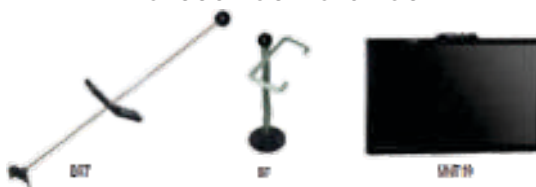

Teknox
METAL CLEANING



FAZ ATÉ 60° C - 230V
RESERVATÓRIO ÚNICO
COM PEDAL DE COMANDO
IDEAL PARA TODAS AS INDÚSTRIAS
ILUMINAÇÃO INTERIOR
PISTOLA DE AR COMPRIMIDO
TEMPERATURA E PRESSÃO AJUSTÁVEIS
TODA EM INOX AISI 304
BOMBA EM AÇO INOX
VIDRO TEMPERADO
AVISO DE NÍVEL MÍNIMO DE ÁGUA

LAVAPEN C

2C
3C
4C

DADOS TÉCNICOS	LP 3C	LP 4C
Capacidade de carga	70 kg	70 kg
Capacidade do reservatório	75 lt	90 lt
Bomba 1	5 bar 2 lt/min 2 bar 5 lt/min	5 bar 2 lt/min 2 bar 5 lt/min
Alimentação	Pneumatica	Pneumatica
	€ 4.140	€ 4.635



OPCIONAIS

DESOLEADOR A DISCO
COM MOTORIZAÇÃO

€ 365



FILTRO PARA RECOLHA
DE SÓLIDOS E GORDURA

€ 620

MÁQUINAS DE LAVAR PEÇAS

FECHO ASSISTIDO - LUVAS LATEX
LANÇA ESPECIAL
PUNHO ANTIDESLIZANTE
ILUMINAÇÃO LED INTERIOR

MÁQUINA DE LAVAR
PEÇAS ALTA PRESSÃO

CAP. DE CARGA - 70 KG
RESERVATÓRIO - 75 LT
BOMBA 230 V
1.5 KW - 80 BAR 12.5 LT/MIN
1200 X 850 X 1800 ALTURA



LAVAPEN 3X

DADOS TÉCNICOS	LP 3X	LP 4X
CAPACIDADE	70 kg	70 kg
RESERVATÓRIO	75 L	90 L
BOMBA	1,5 KW 80 bar - 12,5 litros	1,5 KW 80 bar - 12,5 litros
AQUEC. DO TANQUE	3 kW	3 kW
ALIMENTAÇÃO	Monofase	Monofase

€ 5.380 € 5.870

CESTO REFORÇADO GALVANIZADO
FILTRO EM INOX 304
BOMBA ELÉTRICA EM INOX
VÁLVULA DE DESCARGA
SISTEMA DE LAVAGEM
TOTALMENTE EM INOX

MÁQUINA DE LAVAR
PEÇAS AUTOMÁTICA



P 80

€ 4.970

CAPACIDADE DE CARGA - 100 KG
RESERVATÓRIO - 130 LT
0.55 KW - 2.5 BAR - 120 LT/MIN
2.2 KW - 5 BAR - 180 LT/MIN
AQUECIMENTO DO TANQUE 4 KW
400 V - 112 X 105 X 185 CM ABERTA



greentechno

LIMPEZA ULTRASONS

CAPACIDADE 160 LITROS - 100 KG
FREQUÊNCIA 40 KHZ
1500 WATTS DE ULTRASONS
4500 WATTS DE AQUECIMENTO
TRIFÁSICA 400V
PAINEL TOUCH 7' - SISTEMA SSX3
CUBA 680X440X350MM
EM INOX 304 E 316
SISTEMA UP AND DOWN
VARRIMENTO LATERAL DE SUPERFICIE
PRODUTO RECOMENDADO

ecoclean



GTS-16

€ 13.740

CAPACIDADE 160 LITROS - 75 KG
FREQUÊNCIA 40 KHZ
1500 WATTS DE ULTRASONS
3000/4500 WATTS DE AQUECIMENTO
TRIFÁSICA 400V OU MONOFÁSICA 220V
PAINEL TOUCH 4.3' - SISTEMA SSX3
CUBA 680X440X350MM
EM INOX 304 E 316
SISTEMA UP AND DOWN
VARRIMENTO LATERAL DE SUPERFICIE
PRODUTO RECOMENDADO

ecoclean



GT-MOTION

€ 12.580

EQUIPAMENTOS DE OFICINA

Reference



1540-LJN5413

€ 399

ADEQUADO PARA VERIFICAR E AJUSTAR QUALQUER TIPO DE FAROL (FAROL ALTO, BAIXO E FAROL DE NEBLINA) MIN 250 - MAX 1350 MM INCLUSIVE FARÓIS COM LÂMPADAS XENON E LED.
INDICADO PARA VEÍCULOS LIGEIOS, PESADOS E MOTOS.
TELA DE MIRA INTERNA COM ESCALA PARA VEÍCULOS COM VOLANTE À DIREITA E À ESQUERDA.
VISOR DE ALINHAMENTO DE FIO DE AÇO COM SISTEMA DE CALIBRAÇÃO.
SISTEMA DE AJUSTE DE ALTURA COM SISTEMA DE TRAVAMENTO.
LUXÍMETRO DIGITAL.
USO CONFORTÁVEL DEVIDO AO POSICIONAMENTO DAS RODAS
BASE ANTI-QUEDA ROBUSTA.
FORNECIDO COM MANUAIS DE MONTAGEM, OPERAÇÃO E CALIBRAÇÃO.



LH5415-LJN5416

€ 611



DOUBLE LASER

Reference



ADEQUADO PARA VERIFICAR E AJUSTAR QUALQUER TIPO DE FAROL (FAROL ALTO, BAIXO E FAROL DE NEBLINA), MIN 250 - MAX 1350 MM INCLUSIVE FARÓIS COM LÂMPADAS XENON E LED.
INDICADO PARA VEÍCULOS LIGEIOS, PESADOS E MOTOS.
TELA DE MEDIÇÃO REGULÁVEL INTERNA COM ESCALA PARA VEÍCULOS COM VOLANTE À DIREITA E À ESQUERDA.
VISOR DE ALINHAMENTO A LASER + APONTADOR LASER CENTRAL PARA FACILITAR O POSICIONAMENTO DA UNIDADE NA FRENTE DO VEÍCULO.
SISTEMA DE AJUSTE DE ALTURA COM SISTEMA DE TRAVAMENTO.
LUXÍMETRO DIGITAL.
USO CONFORTÁVEL DEVIDO AO POSICIONAMENTO DAS RODAS.
FORNECIDO COM MANUAIS DE MONTAGEM, OPERAÇÃO E CALIBRAÇÃO.

SPIN

MÁQUINA SEMI AUTOMÁTICA PARA MUDANÇA DE OLEO DE CAIXAS AUTOMÁTICAS

DISPLAY GRÁFICO 240X64 - APENAS 4 BOTÕES
SOFTWARE INTUITIVO MULTI-LÍNGUA
MEDIÇÃO DE PRESSÃO DE RETORNO
SELECÇÃO DE PESO ESPECIFICO DO ÓLEO KG/LT
2 BALANÇAS ELECTRÓNICAS - 1 BOMBA 220V
MODO MANUAL OU AUTOMÁTICO
PROTEÇÃO CONTRA SOBRE-PRESSÃO COM RECIRCULAÇÃO AUTOMÁTICA
COMPENSAÇÃO DO COMPRIMENTO DAS MANGUEIRAS
ACTUALIZAÇÃO DE SOFTWARE POR PEN



02.023.60

€ 3.680

(ATF) INSTALAÇÕES DE TESTE AUTORIZADAS



MÁQUINAS PARA REVISÃO E MANUTENÇÃO DE CAIXAS AUTOMÁTICAS

TABLET WI-FI DE 8" 4G
 CONSULTA DIRECTA DA BASE DE DADOS EM LINHA (POR 4G OU WI-FI)
 CONTROLO REMOTO DAS FUNÇÕES E MONITORIZAÇÃO DAS OPERAÇÕES EM CURSO ATRAVÉS DAS ATF'S
 BASE DE DADOS INTEGRADA- RECONHECIMENTO E INVERSÃO AUTOMÁTICA DO FLUXO DE ÓLEO (ELECTRONICAMENTE)
 REGULADOR DE REDUÇÃO DO FLUXO DE ENTRADA (INCORPORADO)
 DIAGNÓSTICO INTEGRADO COM MENSAGENS E GUIA RELACIONADO PARA O SERVIÇO.
 PROCEDIMENTO MELHORADO PARA A SUBSTITUIÇÃO DE NOVOS TANQUES DE ÓLEO (OUTROS TANQUES A PEDIDO)
 FUNÇÕES GUIADAS PARA PROCEDIMENTO MANUAL
 GUIA DE FUNÇÕES PARA LAVAGEM DO RADIADOR E SUBSTITUIÇÃO DO FILTRO
 PROCEDIMENTO ESPECÍFICO PARA DSG
 ALIMENTAÇÃO DUPLA DE 12V DC E 220V AC
 COM ALARME DE BATERIA FRACA E AUTOMÁTICO RECONHECIMENTO DA FONTE DE ENERGIA
 IMPRESSORA INCLUÍDA
 ACESSO DIRECTO AO ÓLEO USADO PARA O Esvaziamento de painéis
 KIT DE ACESSÓRIOS E MANGUEIRAS PARA AUTOMÓVEIS EUROPEUS E ASIÁTICOS



02.023.65

€ 5.590



BASE DE DADOS ONLINE COM INFORMAÇÃO TÉCNICA SOBRE A CAIXA
 (DIAGRAMAS, FOTOS, LOCALIZAÇÃO DOS ACESSÓRIOS, ETC.)



ECRÃ TÁCTIL CA CORES DE 5'
 MEDIÇÃO DA PRESSÃO DO ÓLEO
 SOFTWARE MULTI-LÍNGUA - FUNÇÃO AWS
 FUNÇÃO DE AQUECIMENTO AUTOMÁTICO
 SISTEMA INTEGRADO DE INVERSÃO DO FLUXO DO ÓLEO
 2 NOVOS FILTROS COM ÍMAN
 INJEÇÃO AUTOMÁTICA DE ADITIVO
 BASE DE DADOS ACTUALIZÁVEL POR USB
 TANQUES DE ÓLEO 2X20 LTS NOVOS E RESÍDUOS
 KIT DE ENGATES E MANGUEIRAS PARA VEÍCULOS EUROPEUS E ASIÁTICOS INCLUÍDO
 SMARTPACK (12 MESES DE ACESSO GRATUITO À BASE DE DADOS EM LINHA)
 SOFTWARE PARA MUDANÇA DE ÓLEO DE DIRECÇÃO ASSISTIDA
 BASE DE DADOS INTEGRADA COM MARCA, VERSÃO, NÚMERO DE RÁCIOS, TIPO DE CAIXA DE VELOCIDADES, QUANTIDADE DE ÓLEO E CÓDIGO DO ÓLEO
 IMPRESSORA OPCIONAL

ATF
S-DRIVE 4500 SW



BASE DE DADOS ONLINE COM INFORMAÇÃO TÉCNICA SOBRE A CAIXA
 (DIAGRAMAS, FOTOS, LOCALIZAÇÃO DOS ACESSÓRIOS, ETC.)

02.023.90

€ 4.290

EQUIPAMENTOS DE OFICINA

DUAL GÁS ANALYZER



DISPLAY DE 3.5'
SOFTWARE MULTILÍNGUA
ALIMENTAÇÃO DUPLA 12V - 240V
IMPRESSORA INCLUÍDA
BOMBA DE LAVAGEM DE CÂMARA INTERNA
NORMAS DE PUREZA DE GÁS >95% NORMA VDA
PARA DOIS GAZES R134A, HFO1234YF
E CONTAMINANTES
INCLUI: ENGATES LP PARA R134A E HFO1234YF
MANGUEIRAS TRANSPARENTES
PINÇA 12V VERMELHA E PRETA
FONTE DE ALIMENTAÇÃO 230V

01.000.290

€ 2.920



**BANCO DE TESTES PARA
ALTERNADORES**

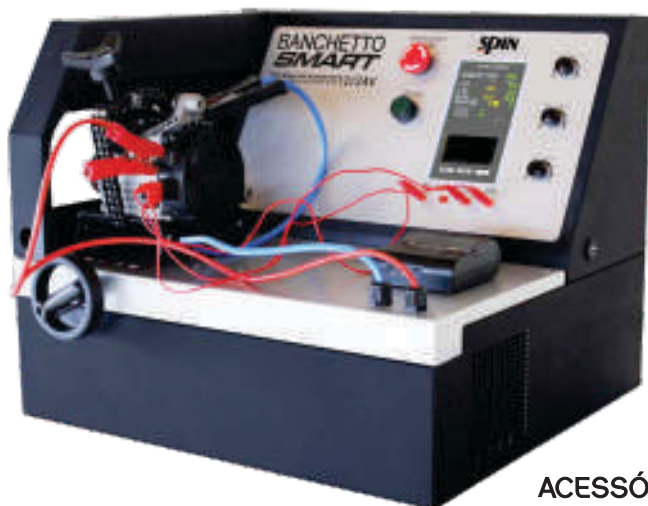

REÓSTATO DE CARGA 0-50A (12V) E 0-25A (24V)
BASE DE DADOS PARA PESQUISAR ALTERNADORES
POR TIPO E POR CÓDIGO
INDICAÇÃO GRÁFICA DOS FIOS A SEREM LIGADOS
POSSIBILIDADE DE AJUSTAR TESTES AUTOMÁTICOS
IMPRESSÃO DE RELATÓRIO
FUNÇÃO OSCILOSCÓPIA - ECRAN TOUCH
BASE DE DADOS ACTUALIZÁVEL POR PEN USB
IMPRESSORA BLUETOOTH INCLUÍDA
230V - 1.5 KW - 0-3000RPM -

02.004.20

€ 2.920

**ACESSÓRIOS
INCLUÍDOS**

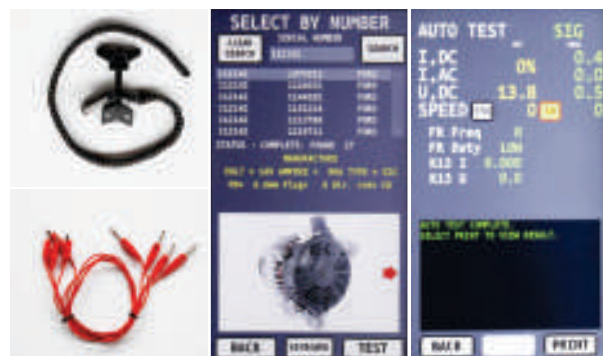

MÁQUINAS DE AR CONDICIONADO



HANDY ADVANCE EVO

DISPLAY GRÁFICO DE 4.7" COM IMPRESSORA
BASE DE DADOS INTEGRADA
INJEÇÃO DE ÓLEO PADRÃO/ADITIVO E INJEÇÃO DE ÓLEO HÍBRIDO (MULTI-OIL SYSTEM)
MULTI LINGUA - GESTÃO DE OPERADOR
PORTA USB - BOMBA 70 LT/MIN
TANQUE - 10 KG | COMPRESSOR 300 GR/MIN
RECUPERAÇÃO AUTOMÁTICA
DESCARGA DE ÓLEO AUTOMÁTICA
CARGA DE GÁS AUTOMÁTICA
LAVAGEM AUTOMÁTICA EM CASO DE MUDANÇA DE ÓLEO



GÁS R1234YF

01.028.63 € 2.655

GÁS R134A

01.028.61 € 2.655



MONOCLIMA BI POWER

COMPRESSOR DE RECUPERAÇÃO AUTOMÁTICA DOS OLEOS
BOMBA DE VACUO - 3M3/H
CAPACIDADE DO CILINDRO - 4.4 KG
220 V 50 HS / 12 V DC
INJECTOR DE OLEO FRESCO



PARA USO EXTERNO
IDEAL PARA MÁQUINAS AGRICOLAS
E MOVIMENTADORAS DE TERRA

BI POWER € 3.350

MONOCLIMA BIPOWER 12V DC-220V AC

COO. 01.009.02



BREEZE ADVANCE DUAL 01.001.43

BANCO DE DADOS INTEGRADO COM ACTUALIZAÇÕES DISPONÍVEIS
DOIS TIPOS DE GÁS COM IMPRESSORA DE SERIE
LIMPEZA AUTOMÁTICA DOS TUBOS DO ÓLEO E CIRCUITOS.
PORTA USB
SOFTWARE MULTI LINGUAS
DISPLAY GRÁFICO (A)
MÁXIMA EFICIÊNCIA (95% DO GÁS)

R 134a
HFO1234 YF

4 MANGUEIRAS
4 ADAPTADORES

IDEAL PARA CARROS LIGEIROS, HYBRIDOS
CAMIÕES, MÁQUINAS AGRICULAS

2 TANQUES
2 X 10 KGS

€ 4.520



SEM CONTAMINAÇÃO INTERNA. 2 EVAPORADORES
2 COMPRESSORES, 2 CONDENSADORES, 2 TANQUES, 2 FILTROS
E LAVAGEM INTERNA AUTOMÁTICA A CADA TROCA.

EXTRACÇÃO DE FUMO E BATE CHAPAS



VÁRIAS MEDIDAS DISPONÍVEIS CONFORME
NECESSIDADE DE APLICAÇÃO
PREÇO SOB CONSULTA



CARRIL EM ALUMÍNIO EXTRUDIDO
ACESSÓRIOS DO CARRO EM INOX
SISTEMA MÓVEL COM APLICAÇÃO
LATERAL OU SUPERIOR

EXTRAÇÃO DE FUMOS E GASES PARA OFICINA



DUPLO

SUPOSTA ATÉ 210° C
POTENCIA 0.55 KW
CAUDAL 1420 MT/H
400 V (230V OPCIONAL)
TUBOS COM 7 METROS

FU-2V-75/7

€ 1.470

SIMPLES

SUPOSTA ATÉ 210° C
POTENCIA 0.18 KW
CAUDAL 1000 MT/H
400 V (230V OPCIONAL)
TUBOS COM 7 METROS

FU-IV-75/7

€ 950



PRIMA



CARRO CAR 2

€ 330

50010700

PREÇO CONJUNTO

€ 1.590



PRIMA TOPCAR 30

€ 1.290

50010028

3000 A SPOT
MICROPROCESSADOR



CONSULTAR FOLHETO PARA MEDIDAS DE BRAÇOS E OPCIONAIS

CAPACIDADE 2+2MM - 220V
 POTÊNCIA CONVÊNIONAL A 50% - 15kva
 CONTROLADA POR MICRO PROCESSADOR DIGITAL 4
 CONFIGURAÇÃO AUTOMÁTICA DE PARÂMETROS
 NA MUDANÇA DE FERRAMENTA
 PISTOLA LEVE E COMPACTA
 FORÇA DO ELETRODO 190 daN
 CABOS FLEXÍVEIS DE SECÇÃO 150 MM E 2.2 MTS
 AQUECIMENTO E ENDIREITAMENTO
 SOLDA FORTE DE PINOS, ARREBITES, PARAFUSOS,
 ARRUELAS E PREGOS.
 SOLDA DE PONTO ÚNICO EM ÁREAS FECHADAS

BATE CHAPAS



PRIMA SPOT 85 8500A DE POTÊNCIA

60010007

€ 3.300

INCLUÍ BRAÇOS DE 200MM



B51 cod 6001-05-02

OPCIONAIS:

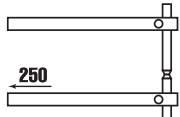

B56 cod 6001-05-08

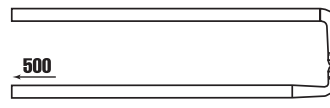

B57 cod 6001-05-09

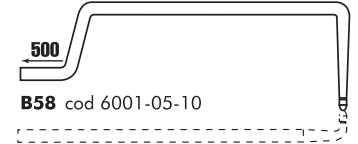

B58 cod 6001-05-10

€ 120

€ 167

€ 198

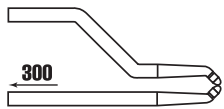

B52 cod 6001-05-03

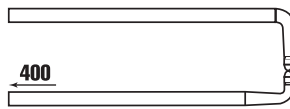

B53 cod 6001-05-04

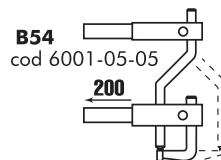

B54 cod 6001-05-05

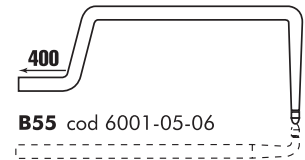

B55 cod 6001-05-06

€ 133

€ 144

€ 278

€ 167

PRIMA

AGRAFADOR A QUENTE DE MATERIAL PLÁSTICO DE AUTOMÓVEIS

PARA REPARAÇÃO E REFORÇO DE PLÁSTICOS
 INCLUI: CAIXA DE FERRAMENTAS DE PLÁSTICO - 1 UNIDADE
 PISTOLAS DE AGRAFOS QUENTES DE PLÁSTICO - 1 UNIDADE
 BIT DE AÇO INOXIDÁVEL mm. 0,6 TIPO 1 (BAG 20 PCS)
 BIT DE AÇO INOXIDÁVEL mm. 0,8 TIPO 1 (BAG 20 PCS)
 BIT DE AÇO INOXIDÁVEL mm. 0,6 TIPO 2 (BAG 20 PCS)
 BIT DE AÇO INOXIDÁVEL mm. 0,8 TIPO 2 (BAG 20 PCS)
 BIT DE AÇO INOXIDÁVEL mm. 0,8 TIPO 3 (BAG 20 PCS)
 CORTADOR LATERAL 1 UNIDADE
 MANUAL DE INSTRUÇÕES
 230V - 50HZ - 50W - 18/20A - 440GRS
 AGRAFOS ATINGEM ATÉ 500°C



HOT SPOT KT

10010201

€ 250



TYPE 1

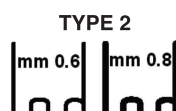

TYPE 2



TYPE 3

DIAGNÓSTICO E BATERIAS



DIAGNÓSTICO TOTAL MOTOS
REPROGRAMAÇÃO DE MOTORES
REPARAÇÃO E SERVIÇO
TESTE DE COMPONENTES
ACTUALIZAÇÕES PERIÓDICAS
CHAVES DE CODIFICAÇÃO
CORTE E AJUSTE DE IMOBILIZADOR
PROGRAMAÇÃO AO RALENTI
REGISTO DE DADOS

MEMOBIKE 6050 € 2.190



CABOS ESPECIAIS OPCIONAIS

**MULTI
MARCAS**

MemoBike 6050

**FICHA
OBD**

MARCO TOOLS
by SPIN

350 A - 25 MM - 3.5 MTS - 05.060.02 € 29

480 A - 35 MM - 4.5 MTS - 05.060.03 € 43

1000 A - 70 MM - 5 MTS - 05.060.04J € 150

CABOS DE BATERIA



PURE 100% COPPER
FRAME PURE 100%

BOOSTER

CARREGADOR BATERIA
1 AMP 240 V
12 V / 24 V - 22AH - 2000A PICO
ADAPTADOR USB
CABO DE ISQUEIRO DUPLO
PEGA ERGONÓMICA
ALICATES COM CONTACTO
EM BRONZE
INDICADOR DE CARGA



03.015.04

€ 456



HELVI®

**ANÁLISE DE BATERIAS
PROFESSIONAL**

12/24V



POLARIDADE INVERSA
PROTECÇÃO CONTRA CURTO CIRCUITO
ECRÃ LCD TOUCH COM GRÁFICOS A CORES
WET, AGM, AGM Spiral EFB, CA & GEL
CCA, SAE, EN, EN1, EN2, IEC, DIN, CA/MCA, JIS
ALTERNADOR E TESTE DE ARRANQUE
TESTE DE LIGAÇÃO À TERRA
IMPRESSORA INCORPORADA
TRANSFERÊNCIA DE DADOS
PARA O PC

99090039

€ 385



BOOSTER - LITIO - COM PROTECÇÃO

INPUT 5 V - 2A OUTPUT 5V-3A
START 200A - PICO 500A - BATERIA 8000 mAh



POWER UP 8.0

99005067

€ 99,9

INPUT 5 V - 3A OUTPUT 5V-3A - 9V-2A - 12V-1.5A
START 300A - PICO 800A - BATERIA 13000 mAh



SUPER POWER 13.0

99005067

€ 128

MEMODERVA



CARREGADORES DE BATERIA



99000069

11A - 12/24V - 390W
CORRENTE DE CARGA 7.5 A

PROGRESS 20

€ 140



99000068

12.5A - 12/24V - 300W
CORRENTE DE CARGA 8.5 A

PROGRESS 17

€ 110

25A - 12/24V - 600W
CORRENTE DE CARGA 17 A

99000072

ARTIK 33

€ 175



18A - 12/24V - 430W
CORRENTE DE CARGA 12 A

99000077

ARTIK 22

€ 160



99000074

DISCOVERY 60
4A - 6/12V - 65W
PARA AGM, GEL, LEAD E
START STOP, LIFePO e Ca/Ca

€ 66

30A - 12/24V - 720W
CORRENTE DE CARGA 20 A
AUTOMÁTICO
PARA AGM, GEL, LEAD E
START STOP
PROFISSIONAL



99000066



99000083

DISCOVERY 120 plus
12V 16A - 24V 8A - 135W
PARA AGM, GEL, LEAD E
START STOP, LIFePO4 e Ca/Ca

€ 99

AUTOMATIC 30

€ 349

27A - 12/24V - 650W
CORRENTE DE CARGA 18 A
PARA BATERIAS DE CHUMBO
BOOSTER MAX 220Acc

99005052

SPEEDY 250

€ 192



42A - 12/24V - 1000W
CORRENTE DE CARGA 28 A
PARA BATERIAS DE CHUMBO
BOOSTER MAX 380Acc

99005031

SPEEDY 430

€ 290



CARREGADORES DE BATERIA

CARREGADOR ESTABILIZADOR DE TENSÃO



EXPLORER 120

100A - 12V - 1600W

€ 950

120A - 12V - 2600W
CORRENTE DE CARGA 120 A
PARA AGM, GEL, LIQUIDO E
LÍTIO (LiFePO4) PROFESSIONAL

FUNÇÃO
AUTO DETECÇÃO

99000085
EXPLORER 130

€ 1.120

PROTEÇÃO CONTRA CURTO-CIRCUITOS
INVERSÃO DE POLARIDADES E SOBRECARGAS
IDEAL PARA USAR EM DIAGNÓSTICO



CARREGADOR COM BOOSTER

RAPID 380

€ 260

99005041



38A - 12/24V - 900W
MAX BOOST 280 Acc
CORRENTE DE CARGA 25 A
PARA BATERIAS DE CHUMBO



CARREGADOR COM BOOSTER

RAPID 480

€ 369

99005053



55A - 12/24V - 1320W - CONECTOR 25 MM
MAX BOOST 450 Acc
CORRENTE DE CARGA 36 A
PARA BATERIAS DE CHUMBO



CARREGADOR COM BOOSTER

SPRINTCAR 341

€ 310

99010046



45A - 12/24V - 1000W - CONECTOR 25 MM
MAX BOOST 300 Acc
PARA BATERIAS DE CHUMBO
COM AMPERIMETRO



CARREGADORES DE BATERIA

GAMA PROFISSIONAL

CARREGADOR COM BOOSTER



75A - 12/24V - 1800W
MAX BOOST 580 Acc
BATERIAS DE CHUMBO
COM AMPERIMETRO



2 OPERADORES
NECESSÁRIOS



SPRINTCAR 640

99010030

€ 520

60A - 12/24V - 1440W
MAX BOOST 330 Acc
BATERIAS DE CHUMBO
COM AMPERIMETRO



SPRINTCAR 540

99010041

€ 440



90A - 12/24V - 2200W
MAX BOOST 1000 Acc
BATERIAS DE CHUMBO
COM AMPERIMETRO

99010038

AUTO STAR 1001

€ 1001



1 OPERADOR
NECESSÁRIO

75A - 12/24V - 1800W
MAX BOOST 580 Acc
BATERIAS DE CHUMBO
COM AMPERIMETRO

99010037

AUTO STAR 701

€ 599



PORQUE TEM ARRANQUE
BOOSTER PROTEGIDO
E CONTROLO LIMITADOR
DE TENSÃO



AGM, GEL, LIQUID OU UNIVERSAL
4 NIVEIS DE CARGA
CARREGAMENTO TOTALMENTE
PROTEGIDO
1320 W - 12/24V - 55A MAX CARGA
36A CORRENTE DE CARGA
260A BOOSTER
3 LEDS INDICADORES DO ESTADO
DA BATERIA

DIGICAR 540 E

99010049

€ 595



AGM, GEL, LIQUID OU UNIVERSAL
4 NIVEIS DE CARGA
CARREGAMENTO TOTALMENTE
PROTEGIDO
1320 W - 12/24V - 55A MAX CARGA
36A CORRENTE DE CARGA
260A BOOSTER
3 LEDS INDICADORES DO ESTADO
DA BATERIA

DIGICAR 1100 E

99010049

€ 815



GERADORES



GERADOR A GASOLINA WX5000

4650 W
ARRANQUE MANUAL
230V
78 KG

PR412SXI000 € 780



GERADOR A GASOLINA

WX6250 - 6100 W
ARRANQUE MANUAL
220V / 380V
90 KG

PR552TX0200

€ 1.250



WX700 - 6500 W
ARRANQUE MANUAL E ELÉTRICO
230V
90 KG

PR582SXB000

€ 1.030

PRAMAC

SÉRIE P INVERTER - MÁXIMO RENDIMENTO COM MENOR CONSUMO



3300 WATTS MÁX
3000 WATTS CONTÍNUA
COMPACTO E ULTRASILENCIOSO
ARRANQUE MANUAL RECOIL
GASOLINA - 230V - 50HZ
505x445x455 2 USB DC 5V 2A
2 TOMADAS 16A

PF312SX1000
P3500I/O

€ 1.050

SISTEMA INVERTER



3300 WATTS MÁX
3000 WATTS CONTÍNUA
COMPACTO E ULTRASILENCIOSO
ARRANQUE MANUAL E ELÉTRICO
GASOLINA - 230V - 50HZ
625x505x580 - 2 USB DC 5V 2A
2 TOMADAS 16A

PF302SXB000
P3500I

€ 1.380

PRAMAC

**GERADOR A GASOLINA
WX3200**

2850 WATTS MÁX
2450 WATTS CONTÍNUA
ARRANQUE MANUAL RECOIL
GASOLINA - 230V - 50HZ
49 KG - 3000 RPM
2 TOMADAS 16A
VOLTÍMETRO E CONTA HORAS

PR242SXIZ00

€ 650



**GERADOR A GASOLINA
WX6200**

5800 WATTS MÁX
5300 WATTS CONTÍNUA
ARRANQUE MANUAL RECOIL
GASOLINA - 230V - 50HZ
49 KG - 3000 RPM
2 TOMADAS 16A
1 TOMADA 2P+T 32A CEE
VOLTÍMETRO E CONTA HORAS

PR532SXIZ00

€ 1.160





GERADORES

GERADOR A GASOLINA WX6250

TRIFÁSICO

6100 WATTS MÁX
5500 WATTS CONTÍNUA
GASOLINA - 400/230V
ARRANQUE ELÉTRICO + MAN
90 KG - 3000 RPM
2 TOMADAS 16A
1 TOMADA 3P+N+T 400V 16A
VOLTÍMETRO E CONTA HORAS
POT. MAX EM MONOFÁSICO 2000W



PR552TXBZ00

€ 1.326

GERADOR A GASOLINA WX7000

6100 WATTS MÁX
5800 WATTS CONTÍNUA
GASOLINA - 230V
ARRANQUE ELÉTRICO + MAN
90 KG - 3000 RPM
2 TOMADAS 230V 16A
1 TOMADA 2P+T CEE 230V 32A
VOLTÍMETRO E CONTA HORAS



PR582SXBZ00

€ 1.400

PRAMAC

SÉRIE E IPROFISSIONAL

MOTOR HONDA GX270
4.600 WATTS MÁX
3.900 WATTS CONTÍNUA
GASOLINA 230V 50HZ
ARRANQUE MANUAL



PA432SH1000
E5000

€ 1.230

MOTOR HONDA GX390
6.400 WATTS MÁX
5.500 WATTS CONTÍNUA
GASOLINA 230V 50HZ
ARRANQUE MANUAL



PA432SH1000
E5000

€ 1.575

PRAMAC

MOTOR HONDA GX390
6.600 WATTS MÁX 400V
5.600 WATTS CONTÍNUA 400V
4.000 WATTS CONTÍNUA 230V
GASOLINA
400/230V 50HZ
ARRANQUE MANUAL

PA702TH1000
E8000

€ 1.825

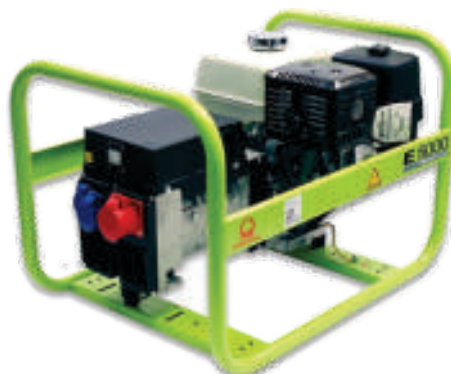

MOTOR HONDA GX270
5.000 WATTS MÁX 400V
4.300 WATTS CONTÍNUA 400V
3.500 WATTS CONTÍNUA 230V
GASOLINA
400/230V 50HZ
ARRANQUE MANUAL

PA543TH1000
E5000

€ 1.650



MOBILIDADE E ELEVAÇÃO



MESA ELEVATÓRIA

ELEVAÇÃO - 900 MM
300 OU 800 KG
MANUAL COM PEDAL
815X500

LT30 € 735

LT80 € 990

PRAMAC



STACKER

ELEVAÇÃO - 1600 MM
1 TON
MANUAL
GARFOS 1150 MM

MX 1016 € 1.580

PRAMAC



STACKER ELÉTRICO

ELEVAÇÃO - 3500 MM
1.2 TON
ELÉTRICO
COM 2 BATERIAS 12 V 85Ah
CARREGADOR DE SERIE

GX12/35 GEL

2 BATERIAS DE GEL 12V/105Ah

€ 7.479

GX12/35 € 7.087



PRAMAC



PORTA PALETES 2.2 TON

RODAS EM NYLON
1150 X 525 MM

GS BASIC 2 € 465
2 RODAS NYLON

GS BASIC S4 € 469
4 RODAS NYLON

GS GALVA S4 € 795
4 RODAS NYLON BRANCO

GS EVO INOX € 2.996
4 RODAS NYLON BRANCO



LUBRIFICAÇÃO





ACESSÓRIOS PARA LUBRIFICAÇÃO



BOMBA DE TRANSFEGA

1792.PN

MANUAL
0.5 LTS POR CICLO
50/200 KG
ÓLEO / DIESEL

€ 24,8

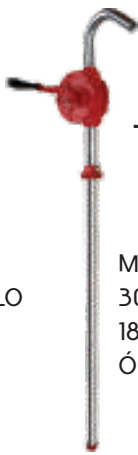

BOMBA DE TRANSFEGA

1792.PR

MANUAL
30 LTS/MIN
180/200 KG
ÓLEO / DIESEL

€ 29



BOMBA DE TRANSFEGA

1792.PRP

MANUAL
ÓLEO / DIESEL / ADBLUE®
IDEAL PARA ADBLUE®
220 L
EPDM 3/4" X 930 MM

€ 53

BOMBA DE TRANSFEGA



1770.D225N

COM PISTOLA MANUAL
40 LTS/MIN
3/4 - 12 V

€ 147

1770.D226N

COM PISTOLA MANUAL
40 LTS/MIN
3/4 - 24 V

€ 161



BOMBA TRANSFEGA GASÓLEO

80 LT/MIN
230 V
1 POLEGADA
PESO: 17.2 KG



1770.D392NS

€ 235

CONTA LITROS GASÓLEO

20-120 LT/MIN
10 BAR
1 POLEGADA
PESO: 1.8 KG



1770.D4CM

€ 110



BOMBA PNEUMÁTICA PARA ÓLEO

1776

180/220 LT
12 LT/MIN - 3:1
TUBO 940 MM

€ 220

BOMBA PNEUMÁTICA PARA ÓLEO

1779

180/220 LT
14 LT/MIN - 5:1
TUBO 940 MM

€ 226

BOMBA PNEUMÁTICA PARA MASSA

1789

180/220 LT
800 GR/MIN - 50:1
TUBO 940 MM

€ 226

BOMBA MASSA
25 KG
R=50

1787

€ 210

BOMBA MASSA
50 KG
R=50

1788

€ 210

ACESSÓRIOS PARA LUBRIFICAÇÃO



DEPÓSITOS DIESEL BONEZZI

CONTA LITROS DIGITAL
E PISTOLA DE ABASTECIMENTO

428/220-KC

220 LTS
40 LTS/MIN
BOMBA 12 V

€ 690

428/440-KC

440 LTS
40 LTS/MIN
BOMBA 12 V

€ 1.040



easylub

ENROLADOR AR / ÁGUA



1731.C4

15 MTS + 1
10X14.5 PVC
20 BAR
3/8

€ 125

CARRINHO COM BOMBA ELÉTRICA

12/24 OU 220 VOLT
IDEAL PARA:
ADBLUE OU UREIA
ÁGUA OU ANTICONGELANTE
60 LITROS
MOTOR Ip55 20/30 L/MIN
EM INOX

738/060BATT

€ 950



easylub

ENROLADOR AUTOMÁTICO PARA ÓLEO



15 MTS
138 BAR
1/2' R1

1732.O

€ 328

15 MTS
155 BAR
3/8' R1

1732.OB

€ 379

ENROLADOR AUTOMÁTICO PARA MASSA



10 MTS
400 BAR
1/4' R2

1732.GA

€ 265

15 MTS
400 BAR
1/4' R2

1732.G

€ 319

RETENÇÃO E LIMPEZA



BOMBA DE MASSA PNEUMÁTICA

1781.E

CARRINHO INCLUIDO
MEMBRANA 285 MM
COM TAMPA
TUBO 4 MTS
PISTOLA DE MASSA COM
RECORD ROTATIVO
25-30 KG
COMPRESSÃO 50:1

€ 342



MÁQ. SANGRAR TRAVÕES PNEUMÁTICA AUTOMÁTICA

5 LTS
6 BAR

1881

€ 219



ADAPTADOR UNIVERSAL

1884

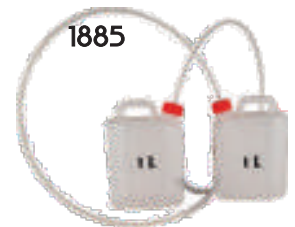

1885

**1881
COM OPCIONAIS
1884 + 1885**

€ 254



ASPIRADOR / RECUPERADOR DE ÓLEO

1839.80

VISOR DE 10 LTS
APARADOR 18 LTS
80 LITROS

€ 439



ASPIRADOR RECUPERADOR OLEO - PNEUMÁTICO

1837.80

COM VISOR 10 LTS
80 LITROS

€ 351



ASPIRADOR RECUPERADOR OLEO - PNEUMÁTICO

1832.80

APARADOR 18 LTS
80 LITROS

€ 328



ASPIRADOR OLEO - PNEUMÁTICO

1830.30

30 LITROS

€ 192



LIMPEZA OFICINA E AUTO

MÁQUINA DE LAVAR PEÇAS



720 X 550 MM
40 KG - 25 LTS
3 DEPÓSITOS
4 NIVELADORES
MANGUEIRA COM PINCEL

TBP780

€ 460

MÁQUINA DE LAVAR PEÇAS



65 LITROS
220 V

1970.E

€ 197



PISTOLA PESA AR

MOSTRADOR
DIGITAL

1863.DAS

€ 52



ESPRESSOR DE PANOS MANUAL

1951

€ 113



CONJUNTO COM CARRO PARA ÓLEO 180/220 LTS

COM PISTOLA DIGITAL

1762 € 567

COM PISTOLA MANUAL

1762.A € 485

PISTOLA DIGITAL CONTA LITROS



IDEAL PARA OLEOS
BICO AUOMÁTICO 1/2'

1767.D

€ 132.9

ACESSÓRIOS PARA LUBRIFICAÇÃO

BOMBA DE MASSA

1786.OC

MANUAL
400 GR
400 BAR MAX



€ 23,5

BOMBA DE MASSA

1786.3N

PNEUMÁTICA
400 GR
400 BAR MAX



€ 35,5



BOMBA DE MASSA

1797A

12 KG
1.5 METROS

€ 70



1797

16 KG
1.5 METROS

€ 78

BOMBA DE MASSA

1798

MANUAL
COM RODAS
16 KG
2.5 METROS



€ 81



BOMBA DE OLEO

1795A

MANUAL
12 KG
1.5 METROS

€ 56



BOMBA DE OLEO

1796

MANUAL
COM RODAS
16 KG
2.5 METROS

€ 67



ACESSÓRIOS PARA LUBRIFICAÇÃO

NEBULIZADOR
PNEUMÁTICO

1920

24 LITROS
VALV. SEG. 8 BAR

€ 186



RECUPERADOR
ÓLEO - PNEUMÁTICO

1803.80

APARADOR 18 LTS
80 LITROS

€ 224



PUVERIZADOR DE
ESPUMA PNEUMÁTICO

1942

24 LITROS
VALV. SEG. 8 BAR

€ 215



PUVERIZADOR DE ESPUMA
PNEUMÁTICO

1940

23 LITROS
INOX
VALV. SEG. 8 BAR

€ 393



SERINGA DE VALVOLINA

1795.F10

AÇO
PONTEIRA RIJA
1000 GR

€ 18,6



SERINGA DE VALVOLINA

1795.F5

AÇO
PONTEIRA RIJA
500 GR

€ 11,5



PRODUTOS PARA OFICINA

BACIAS DE RETENÇÃO

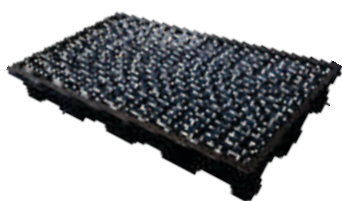

60 LITROS
1285 x 685 x 150
1BR60

€ 199

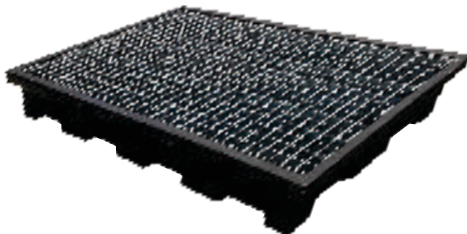

120 LITROS
1285 x 1285 x 150
1BR120

€ 469

CAIXA DE RETENÇÃO



PARA BATERIAS AUTO
780X480X600
1CBP

€ 229



**PANO MULTIUSOS
PARA DETAIL**

410
PRODYLENE

**TECIDO
NÃO TECIDO**

€ 40,4

PANO BRANCO LIMPEZA
ROLO 115 METROS
50 GR - 25X38 CM
70% FIBRA 30% AGLUTINANTE



**SUPORTE
CHÃO**

96 X 50 CM

605

€ 37



**SUPORTE
PAREDE**

37 X 37 CM

610

€ 26



**ROLO DE PAPEL
331BLU180**



PALETE - 60 ROLOS

**ROLO DE PAPEL
320180**



PALETE - 60 ROLOS



PACK 2 UNIDADES
COR AZUL
3 FOLHAS
194 MTS LINEARES
24 X 38 CM FOLHA

€ 26,8



PACK 2 UNIDADES
COR BRANCO
3 FOLHAS
194 MTS LINEARES
24 X 38 CM FOLHA

€ 26,8



ACESSÓRIOS PARA LUBRIFICAÇÃO

ABSORVENTE RÁPIDO

REUTILIZÁVEL ATÉ À SATURAÇÃO
 QUIMICAMENTE NEUTRO
 ABSORVE TODO O TIPO DE LÍQUIDOS
 RETARDANTE DE FOGO E PRODUTOS INERTES
 INDICADO PARA OFICINAS, INDÚSTRIA, HIDRÁULICA,
 GESTORES DE RESÍDUOS, MANUTENÇÃO DE
 ESTRADAS, AVIAÇÃO...



ABSORÇÃO DE ÁGUA - 110 %
 ABSORÇÃO DE ÓLEO - 70 %

SEPIOLITA



S20/40RP
 SACOS DE 20 KG

€ 13,06



316
 MASSA DE JUNTAS
 -50° ATÉ 300°
 ALTA EFICIENCIA 90 GR

cx 30 un

€ 4,25



873
 SHAMPOO NEUTRO
 LAVAGEM 20 LT

cx 1 un

€ 31



869N
 ANTI CORROSÃO
 RESINA E ZINCO
 400 ML

€ 6,10



501
 HIGIENIZADOR DE
 INTERIORES
 500 ML

€ 3,07



MASSA LAVAR
 MÃOS

851PL

5 KG
 CONCENTRADA
 PERFUMADA
 ALTAMENTE EFICAZ



€ 11,9



DETERGENTE LAVAGEM
 PAVIMENTOS

871

CAIXA 6 UNIDADES

€ 66

SPRAYS DIVERSOS

GAMA DE PRODUTOS PROFISSIONAL PARA LIMPEZA E MANUTENÇÃO DE VEÍCULOS AUTOMÓVEIS

802
SPRAY REMOÇÃO
ALCATRÃO
400 ML



cx 24 un

€ 3,16

807/2
SPRAY LIMPEZA
DE TRAVÕES
500 ML



cx 12 un

€ 2,15

812NO-SIL
COCKPIT SPRAY
SEM SILICONE
500 ML



cx 24 un

€ 3,5

852
SPRAY LIMPEZA
VIDROS
400 ML



cx 24 un

€ 2,36

813
SPRAY HIGIENIZANTE
AR CONDICIONADO
200 ML



cx 24 un

€ 5,45

830
SPRAY RLUBRIFICADOR
DE CORRENTES
400 ML



cx 12 un

€ 4,70

804
SPRAY LIMPA
CARBURADORES
400 ML



cx 12 un

€ 4,80

300
SPRAY REMOVEDOR
ANTI-FERRUGEM
400 ML



cx 24 un

€ 2,84

301
SPRAY REMOVEDOR
SUPER ANTI-FERRUGEM
400 ML



cx 24 un

€ 3,60

400 S
SPRAY ZYNCO
96 % COR ESCURA
400 ML



cx 12 un

€ 5,2

410
SPRAY SOPRADOR
LIMPEZA DE COMPONENTES
ELETRÔNICOS - 400 ML



cx 12 un

€ 4,12

810
MASSA DE
ESCAPES
170 GR



cx 12 un

€ 3,43

817
SPRAY DESMOLDANTE
ANTI-GRAINHAS
SILICONE - 400 ML



cx 24 un

€ 3

315
MASSA DE JUNTAS
50 A 300°C
90 GR



cx 30 un

€ 3,53

400 C
SPRAY ZYNCO
96 % COR CLARA
400 ML



cx 12 un

€ 5,5



METALOMECÂNICA





DISCOS

DISCO DE CORTE INOX BLUE LINE



112303 - 115x1,0x22
cx 100 un **€ 0,59**

03030 - 125x1,0x22
cx 100 un **€ 0,68**

114103 - 180x1,9x22 - 1.02
cx 50 un **€ 1,13**

113803 - 230x1,9x22 - 1.62
cx 50 un **€ 1,66**



DISCO DE CORTE FERRO

100702 - 115x3,2x22 BlueLine
cx 50 un **€ 0,62**

101802 - 125x3,2x22 BlueLine
cx 50 un **€ 0,71**

GRANDINETTI

101502 - 180x3,2x22 BlueLine
cx 50 un **€ 0,99**

102002 - 230x3,2x22 BlueLine
cx 50 un **€ 1,61**



DISCO DE REBARBAR FERRO

100801 - 115x4.8x22 BlueLine
cx 50 un **€ 0,99**

101201 - 125x6.4x22 BlueLine
cx 50 un **€ 1,22**

101801 - 180x6,4x22 BlueLine
cx 25 un **€ 1,75**

102401 - 230x6,4x22 BlueLine
cx 25 un **€ 2,77**



DISCO DE CORTE INOX PREMIUM +30

115603 - 115x1,0x22
cx 100 un **€ 0,63**

115803 - 125x1,0x22
cx 100 un **€ 0,70**

DISCO DE CORTE PREMIUM +30

114802 - 115x3,2x22 - 1.02
cx 50 un **€ 0.76**



DISCO LAMELADO INOX

GRANDINETTI



204104 - 115 - GRÃO 40 FIBRA
cx 25 un **€ 1,41**

204204 - 115 - GRÃO 60 FIBRA
cx 25 un **€ 1,41**

204304 - 115 - GRÃO 80 FIBRA
cx 25 un **€ 1,41**

L115Z100TFC - 115 - GRÃO 100 FIBRA
cx 25 un **€ 1,41**

200704 - 115 - GRÃO 120 FIBRA
cx 25 un **€ 1,41**

L125Z040TFP - 125 - GRÃO 40 CÓNICO
cx 20 un **€ 1,98**

L125Z060TPF - 125 - GRÃO 60 CÓNICO
cx 20 un **€ 1,98**

L125Z080TPF - 125 - GRÃO 80 CÓNICO
cx 20 un **€ 1,98**

L125Z100TFC - 125 - GRÃO 100 CÓNICO
cx 20 un **€ 1,98**

L125Z100TFC - 125 - GRÃO 120 CÓNICO
cx 20 un **€ 1,98**

SOLDADURA



**INVERTER
ECF-1400**

INVERTER
10-140 AMP
230 V - MMA E TIG
COM MALA,
ALICATE E CABO MASSA

S00173



298



**INVERTER
ECF-1600**

INVERTER C/ DISPLAY
10-160 AMP
230 V - MMA E TIG
COM MALA,
ALICATE E CABO MASSA

S00171



490



**INVERTER
ECF-2000**

INVERTER C/ DISPLAY
10-200 AMP
230 V - MMA E TIG
COM MALA,
ALICATE E CABO MASSA
60% 150 A

S00172



560



TOCHA TIG BINZEL 4MT
PARA ECF 1400 E ECF 1600
CONEXÃO - 25 MM

535710



195



TIG 2022 DC HF

200 A - HOT START
SLOPE DOWN
2T / 4 T
7.3 KG - 230 V
25% - 200A
60% - 120A
100% - 100A

S00151



755



TOCHA TIG SR17V
CONEXÃO - 50MM
PARA ECF-2000 E TIG 2022

535801



260

TOCHA BINZEL
ABITIG 26 V
PARA ECF-2000

535717



260



SOLDADURA



TIG 2005 AC / DC HF

200 A - HOT START
SLOPE DOWN
2T / 4 T
11.2 KG - 230 V
EM AC FUNÇÃO DE LIMPEZA
FREQUÊNCIA AJUSTÁVEL
IDEAL PARA INOX, FERRO, AÇO
TITÂNIO, ALUMÍNIO E MAGNÉSIO

PULSADO



TOCHA ABITIG 26
4 MT
PARA 2005 AC / DC HF

S00161 € 1.760

535802 € 370



SEMIAUTOMÁTICA COMPACTA MIG2400/A

COM TOCHA TE140 DE 2.2MTS
E CABO DE MASSA
PUXA FIO 2 ROLETES
FLUXÓMETRO
15-220 AMP

200 AMP

S00270 € 1.290



300 AMP

OPÇÃO MIG 3300
2 ROLETES

S00259.64 € 1.625



MIG MAG

SEMIAUTOMÁTICA COMPACTA MIG3300

COM TOCHA DE 4 MT
E CABO DE MASSA
PUXA FIO 4 ROLETES
FLUXÓMETRO
25-300 AMP - 400V

S00259.A7 € 1.850



FIO DE 0.6 A 1.2 MM
BOBINES DE 15 KG Ø300
POSIÇÕES 2X8
PESO 92 KG
PREPARADA PARA SISTEMA
DE ARREFECIMENTO

MIG MAG

SEMIAUTOMÁTICA COMPACTA
MIG 4100



SOLDADURA

TOCHA ARREFECIDA
535019 M501 3 METROS

€ 290

GRUPO ARREFECEDOR 5 LT
560010.A25 CU06H

€ 999

COM TOCHA DE 3 MT
CABO DE MASSA
PUXA FIO 4 ROLETES
MÚLTIPLA IMPEDÂNCIA
FLUXÓMETRO
35-400 AMP - 400V

400 AMP

S00271

€ 2.300



PRO MIG 420

5-400 A - 400V
40% 350A - 60% 290A - 100% 220A
COM PUXA FIO 4 ROLETES,
TOCHA 4 MTS M36,
PROLONGADOR DE 4+1.5 MTS
E FLUXÓMETRO INCLUÍDOS
MÚLTIPLAS IMPEDÂNCIAS
PESO 123 KG

COM CARRO

400 AMP

S00279.37

PREÇO
CONJUNTO € 2.580



SYNERGIC PRO MIG 490

30-400 AMP - 400V
220A A 100% - 290A A 60%
PREÇO CONJUNTO

S00288 € 4.650

SINÉRGICA

STAND-BY TEMPORIZADO
2T - 4 T - PÓS GÁS
COM PUXA FIO 4 ROLETES,
GRUPO ARREFECEDOR,
TOCHA ARREFECIDA 4 MTS M501D,
PROLONGADOR DE 5 MTS
E FLUXÓMETRO INCLUÍDOS



SYNERGIC PRO MIG 520

40-450 AMP - 400V
250A A 100% - 330A A 60%
PREÇO CONJUNTO

S00300 € 5.300



SOLDADURA



COMBO HI-MIG 2010

MIG - 30% 200A - 100% 140A
 TIG - 30% 200A - 100% 140A
 MMA - 40% 160A - 100% 120A
 BOBINE DE FIO Ø200MM - 5KG
 TIG PULSADO
 PFC (Power Factor Correction)
 NA FUNÇÃO MIG/MAG TEM O MODO
 SINÉRGICO OU PULSADO
 PARA FERRO, INOX, ALUMINIO,
 BRASAGEM E ARAME FLUXADO
 COM TOCHA M25 -4 MTS

S00218+535014

€ 2.290

S01705A.10

KIT SOLDADURA - MASCARA
 CABO DE MASSA E ALICATE MMA 25MM

€ 78

535718

TOCHA ABITIG 26
 4 MTS - EURO CONECTOR

€ 460

MIG/MAG, MMA E TIG LIFT

MIG SINÉRGICA
 TIG LIFT PULSADO

MMA
 CARRO OPCIONAL
 DUPLO PULSADO OPCIONAL

PERFEITA PARA
 ASSISTÊNCIAS
 COM PASSWORD
 PESO: 18 KG

540180

DUPLO PULSADO

€ 440



COMBO HI-MIG 3020



MIG/TIG - 40% 270A - 100% 200A
 MMA - 40% 220A - 100% 180A
 BOBINE DE FIO Ø200MM - 5KG
 TIG PULSADO
 PFC (Power Factor Correction)
 DISPLAY A CORES 4.3"
 NA FUNÇÃO MIG/MAG TEM O MODO
 SINÉRGICO OU PULSADO
 PARA FERRO, INOX, ALUMINIO,
 BRASAGEM E ARAME FLUXADO

S00384

€ 3.290

MIG SINÉRGICA
 TIG LIFT PULSADO
 MMA

PREPARADA PARA
 GRUPO ARREFECEDOR

S01704A.10

KIT SOLDADURA - MASCARA
 CABO DE MASSA E ALICATE MMA 35 MM

€ 180

535014

TOCHA M 25 4 MTS

€ 174

4 ROLETES

560102

CU56A- GRUPO
 ARREFECEDOR 5LTS

€ 1.200

535019

TOCHA ARREFECIDA
 M501 - 3 MTS

€ 330

580007
 CARRO

€ 450

540181

DUPLO PULSADO

€ 440

535718

TOCHA ABITIG 26
 4 MTS - EURO CONECTOR

€ 460





MIG/MAG, MMA E TIG LIFT

SOLDADURA

560102

CU56A- GRUPO ARREFECEDOR 5LTS

€ 1.200

535020

TOCHA ARREFECIDA M501 - 4 MTS

€ 363

535718

TOCHA ABITIG 26 4 MTS - EURO CONECTOR

€ 460

PREPARADA PARA GRUPO ARREFECEDOR COMBO HI-MIG 4020 320 A

MIG/TIG - 35% 320A - 100% 270A

MMA - 50% 270A - 100% 230A

BOBINE DE FIO Ø200MM - 5KG

TIG PULSADO

PFC (Power Factor Correction)

NA FUNÇÃO MIG/MAG TEM O MODO SINÉRGICO OU PULSADO

PARA FERRO, INOX, ALUMINIO, BRASAGEM E ARAME FLUXADO

S00385

€ 3.810

4 ROLETES

S01704A.10

580007

CARRO

€ 320

KIT SOLDADURA - MASCARA CABO DE MASSA E ALICATE MMA 35 MM

€ 180

535016

TOCHA M 36 4 MTS

€ 232

540181

DUPLO PULSADO

€ 440



INVERTER PRO MIG 566 DUPLO PULSADO - 520A

SYNERGICA, 4 ROLETES

CARRO E GRUPO ARREFECEDOR E ROOT

IDEAL PARA SERRALHARIA MÉDIA/PESADA

MIG/MAG, MMA E TIG DC (PULSADO)

DISPLAY 4.3" ALTA RESOLUÇÃO

CONEXÃO TOCHA EURO

TOCHA M501 4 MTS, CABO MASSA

VÁRIOS MODOS PRÉ CONFIGURADOS

10 A 520 AMP (320 PULSADO) - 400V

100% - 440A / 60% - 470A / 40% - 500A

COM CARRO WF 440 DIGITAL

COM KIT DE SOLDADURA E CABO MASSA 5+3.5MT

COM PROLONGADOR 5 MTS

S00315.A13+535020+

S01706A.10+530340

€ 8.900

PREÇO CONJUNTO

535718

TOCHA ABITIG 26

4 MTS - EURO CONECTOR

€ 460



MULTI-PROCESSOS E GOUGING

MULTIPROCESSOS



MAXITECH EVO 506

PROGRAMAS SYNERGICA, 4 ROLETES
IDEAL PARA SERRALHARIA PESADA
MIG/MAG, MMA E TIG DC (PULSADO)
DISPLAY 3.3" ALTA RESOLUÇÃO
CONEXÃO TOCHA EURO
INCLUI: GRUPO ARREFECEDOR 5LT
TOCHA 4 MTS, CABO DE MASSA 70MM,
CARRO F4W, PROLONGADOR 5 MT
FIO DE Ø0.8 A Ø1.6
MEMÓRIA PARA MAIS DE 200 PONTOS
ACTUALIZAÇÕES POR USB
ALUMÍNIO, INOX FERRO E FLUXADO.

99855009K

€ 6.900

MIG/MAG
TIG LIFT
MMA

GOUGING (ARC-AIR, GOIVAGEM
COM ELETRODO DE CARVÃO)



OPCIONAIS:

PULSADO / DUPLO PULSADO
04600452

€ 910



STORM VISION 4.1



LINHA PROFISSIONAL

21905151 € 980

CLASSE 1/1/1/1
DIMENSÃO DO FILTRO 133X114X9MM
GRAUS DE ESCURECIMENTO 5-8 /9-13
VARIÁVEL
PROTEÇÃO UV DIN16
RAPIDEZ DE DISPARO 1/25000 SEG
TEMPO DE OFF 0.05-1.0 SEG
SENSIBILIDADE 10 NÍVEIS
BATERIA 9 HORAS
TEMPO DE CARGA 1 HORA
EFICIENCIA DO FILTRO 99.97%
2 NIVEIS DE FLUXO DE AR

LUVAS TIG



EM PELE
TAMANHOS 9 E 10
EN 388:2016
EN 407: 2004
EN 420:2003+A1:2009
EN 12477:2001+2005

21905133

€ 11.2



2 METROS
16MM2
180 AMP
DA 25MM2



43210138K € 25

2 METROS
25MM2
300 AMP
DA 50MM2
43210170K



€ 39

3 METROS
35MM2
400 AMP
DA 50MM2
43210142K



€ 68



PLASMA DE CORTE

CARACTERÍSTICAS DE PLASMAS DA ELECTRO CF

- ARCO PILOTO PARA CORTAR METAIS PINTADOS OU REVESTIDOS. - PÓS-GÁS.
- SISTEMAS DE SEGURANÇA SOBRE A TOCHA. - CONTROLO DA PRESENÇA DE PRESSÃO DE AR COMPRIMIDO.
- TECNOLOGIA DE ULTRA CORTE DE CAPACIDADE PARA MELHORAR AS CAPACIDADES DE CORTE EM ESPESSURAS ELEVADAS.
- TECNOLOGIA INOVADORA DE CORTE FINO QUE PERMITE OBTER CORTES DE QUALIDADE SUPERIOR E REDUÇÃO DO CORTE (QUANTIDADE DE MATERIAL REMOVIDO). - TECNOLOGIA HYPER SPEED CUT, QUE AUMENTA A VELOCIDADE DE CORTE.
- TECNOLOGIA MULTI PIERCING: POSSIBILIDADE DE PERFURAÇÃO EM ESPESSURAS ELEVADAS NUM TEMPO MAIS CURTO E COM MENOR DESGASTE DOS CONSUMÍVEIS. - TECNOLOGIA EXTRA LIFE E TECNOLOGIA LOW PILOT ARC QUE AUMENTA OS DESEMPENHOS E A DURAÇÃO DOS CONSUMÍVEIS.
- TECNOLOGIA DE PONTA LONGA QUE PERMITE CORTAR PRÓXIMO DE ÂNGULOS MUITO ESTREITOS E ESPAÇOS PEQUENOS.
- PARÂMETROS E FUNÇÕES DE CORTE CONTROLADOS POR MICROPROCESSADOR. - SISTEMAS DE SEGURANÇA NA TOCHA.

PLASMA 30-16 PFC INVERTER

230V
CORTE ATÉ 12 MM
SEPARAÇÃO 16 MM
TOCHA MANUAL P25 - 4 MTS
5 BAR - 190 LTS/MIN
9.5 KG PESO

P00479 € 1.290

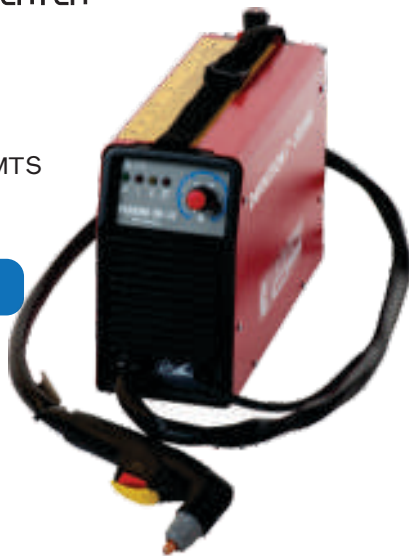

PLASMA 36 COMPRESSOR INVERTER PFC

230V
CORTE ATÉ 12MM
SEPARAÇÃO 16 MM
TOCHA MANUAL P25 4 MTS
COMPRESSOR INCORPORADO
16 KG PESO

P00481 € 1.600



PLASMA 50-24 INVERTER

400V
CORTE DE 13 MM A 20 MM
SEPARAÇÃO 25 MM
TOCHA MANUAL ECF-71 4 MTS
5 BAR - 170 LT/MIN
18 KG PESO

P00442 € 2.200



PLASMA 70-35 INVERTER

400V
CORTE DE 19 MM A 25 MM
SEPARAÇÃO 35 MM
TOCHA MANUAL ECF-71 6 MTS
5 KG - 190 LTS/MIN
22 KG PESO

P00452 € 2.616



SOLDADURA POR PONTOS

SOLDADURA POR PONTOS COM BRAÇO OSCILANTE



BSP RF

COM PEDAL PNEUMÁTICO BSM RF
 20 kVA A 50% DE POTÊNCIA
 11.5 kA MAX CORRENTE
 9.2 kA CORRENTE MAX DE SOLDADURA
 FORÇA DO ELETRODO 6 bar
 300 MM DE PROFUNDIDADE ÚTIL
 TRIFÁSICA 400V - 50HZ - 32A
 ROBUSTA, TERMOSTATO DE SEGURANÇA
 CONTROLO SCR SINCRONO
 BRAÇOS AJUSTÁVEIS EM PROFUNDIDADE
 PREPARADA PARA ARREFECIMENTO A ÁGUA
 DIAMETRO DO BRAÇO Ø45 - ABERTURA ELETRODOS 6-50

ZC1131
 BSP221RFS2

€ 3.150



CONTROLADOR S2

OPCIONAIS:

GRUPO ARREFECEDOR

XAE037 - GRUPO ARREFECEDOR
 2 LP 380V

€ 990

PAR DE BRAÇOS STANDARD ARREFECEDOR ÁGUA Ø45 MM

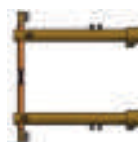

XBCC180 - CB80 PAR DE BRAÇOS Ø45X500MM
 COM ELETRODO Ø20X185

€ 489

XBCC190 - CB90 PAR DE BRAÇOS Ø45X700MM
 COM ELETRODO Ø20X185

€ 580

PAR DE BRAÇOS REFRIGERADO A ÁGUA Ø45MM COM BRAÇO INFERIOR DE TAMANHO REDUZIDO 410-700 MM

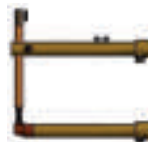

XBCC210 - CB90TTD - BSP - PAR DE BRAÇOS
 AJUSTÁVEIS Ø45X700MM

€ 760

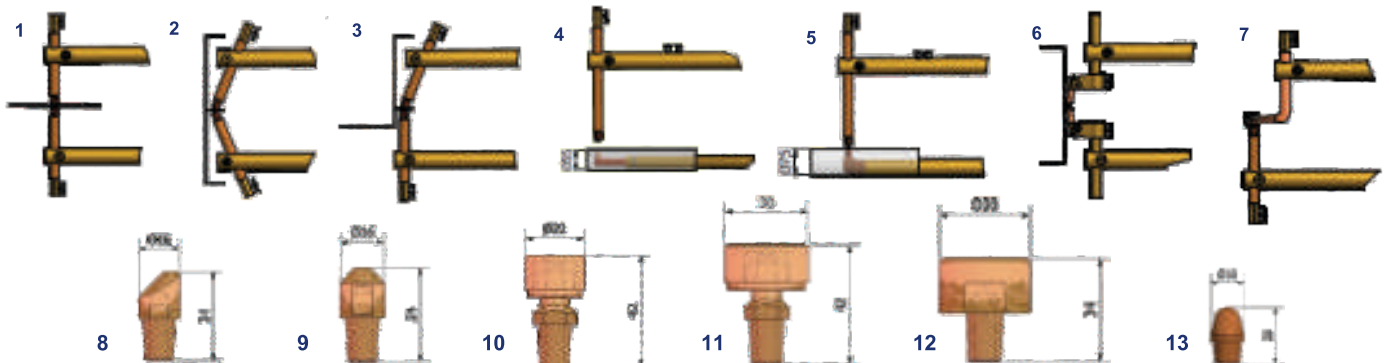

MANÓMETROS E MAÇARICOS



DEBITÓMETRO + FLUXOMETRO

25450 € 79



DEBITÓMETRO CO2

25500 € 58



MANOREDUTOR OXIGÉNIO

25000 € 58



DEBITÓMETRO CO2

25550 € 45



DEBITÓMETRO AZOTO

25400 € 58



MANOREDUTOR ACETILENO

25100 € 58



MAÇARICO CORTE

19520 € 94,5



ESTRELA DE 6 BICOS

10500/A € 13,9

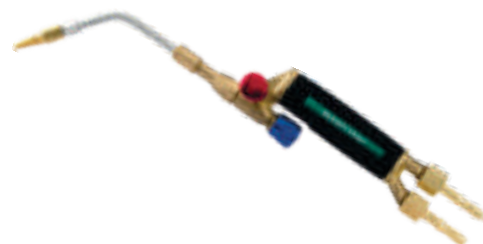

MAÇARICO SOLDAR
ESTRELA DE BICOS INCLUIDA

10400/A € 63,2



CUNHO PARA ESTANHAR
VULCANO

43221304 € 15,33



PUNHO + LANÇA
VULCANO

43221104 +
43221144 € 13,20



CAMPANULAS
VULCANO

43221224 - 45MM € 7,14

43221234 - 60 MM € 8,58



CONSUMÍVEIS DE SOLDADURA

TOCHA ARREFECIDA 4 MTS
134P4U1040

€ 149,7



TOCHA TBI BASIC 250

TOCHA TBI BASIC 360

104P3U1030 € 63,9
3 MTS

114P3U1030 € 86,1
3 MTS

104P3U1040 € 68,4
4 MTS

114P3U1040 € 92,8
4 MTS

104P3U1050 € 76,9
5 MTS

114P3U1050 € 104,2
5 MTS

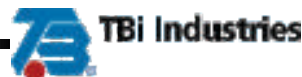

BICO COBRE M6

BICO COBRE M6

BICO COBRE M8

340P081073 € 0,35
0.8 MM L-25MM ECU

340P081069 € 0,48
0.8 MM L-28 MM

340P081262 € 0,65
0.8 MM L-30 MM

340P101073 € 0,36
1 MM L-25MM ECU

340P101069 € 0,48
1 MM L-28 MM

340P101262 € 0,65
1 MM L-30 MM

340P121073 € 0,36
1.2 MM L-25MM ECU



DIFUSOR DE GÁS

114P102004
BRANCO TOCHA 360

€ 0,95



SUPORTE CONTACTO

342P006003 € 1,25
M6 L35 TOCHA 250

342P006014 € 1,25
M6 L 28 TOCHA 360



BOCAL CILINDRICO

345P312003 € 3,4
DIAM. 15 BASIC 250

345P312010 € 4,5
DIAM. 16 BASIC 360

EQUIPAMENTOS DE PROTEÇÃO INDIVIDUAL



**LUVAS PROTEÇÃO
301**

NIVEL 4 - ESP. 1.7 MM
TAMANHO ÚNICO
EN 388 - EN 420

€ 4,5



**MASCARA DE SOLDAR
420**

REACÇÃO 0.1 MS
RETORNO 0.4 MS
DETETORES LUZ 2 CINI9C

€ 39,3



**MÁSCARA DE MÃO
419**

FIBRA DE VIDRO
VIDRO 110X55
VIDRO 12

€ 9,8



**AURICULARES DE PROTEÇÃO
CLIMAX13**

ESPUMA DE PU
DESCARTÁVEIS
SNR = 38 dB

€ 0,25



**ÓCULOS PROTECÇÃO OXICORTE
620**

CLASSE ÓPTICA 1
VIDRO 3 MM ESPESSURA
TONS DISPONÍVEIS - 4/6

€ 3,8



**VISEIRA DE PROTEÇÃO
424RN**

GRAU 5 PARA OXICORTE
CLASSE OTICA 2
320 X 190 MM
EN 169 | EN 175

€ 3,8



**MANGUITOS PROTEÇÃO
MANGUITOS 8**

CLASSE PROTECÇÃO 2 A1+A2
COURO DE VACA
AJUSTE EM VELCRO

€ 10,5



**PROTEÇÃO BOTAS OXICORTE
POLAINAS 9**

CLASSE PROTECÇÃO 2 A1+A2
COURO DE VACA
AJUSTE EM VELCRO

€ 10,3

CONSUMÍVEIS DE SOLDADURA



**MÁSCARA DE PROTEÇÃO
1710**

FFFP1
IDEAL PARA CONSTRUÇÃO, POEIRAS
ÓXIDOS, NÉVOA E FUMOS
BANDAS DE AJUSTE SINTÉTICAS
8-10 HORAS USO
CAIXA COM 20 UNIDADES

€ 0,55



**MÁSCARA DE PROTEÇÃO
1710-V**

FFFP1 - COM VÁLVULA DE EXPIRAÇÃO
IDEAL PARA CONSTRUÇÃO, POEIRAS
ÓXIDOS, NÉVOA E FUMOS
RESISTÊNCIA RESPIRATÓRIA BAIXA
8-10 HORAS USO
CAIXA COM 20 UNIDADES

**MÁSCARA PARA PINTURA
755**



MODELO 755-A1
FILTROS 755 E 756
BORRACHA TERMOPLÁSTICA

€ 12,6



**SEMI MÁSCARA FLÉXIVEL
756**

MÁSCARA EM BORRACHA NATURAL
COMPATIVEL COM FILTROS 755/756
FATOR PROTEÇÃO 50
PESO 215G

€ 13,99

**ÓCULOS DE PROTEÇÃO
569-I**



POLICARBONATO
EN 166:2001 EN 170:2002
TAMANHO ÚNICO

€ 2,10

**ÓCULOS DE PROTEÇÃO
590-I**



POLICARBONATO
EN 166:2001 EN 170:2002
TAMANHO ÚNICO

€ 1,9

**MASCARA DE PROTEÇÃO
761 A1**



NPF 50 - PESO 150GR
AJUSTÁVEL
FILTROS 760

€ 12,10



**ABAFADORES
CLIMAX 10**

HIPOALERGÉNICO
TAMANHO S, L, M
EN 352-1 CE

€ 5,9

OUTLET DE TESOURAS E PRENSAS

ACESSÓRIOS PARA METALMECÂNICA

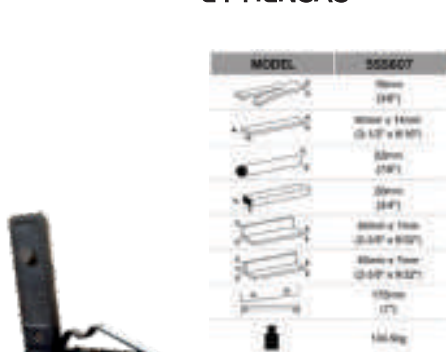

5SS607

€ 863

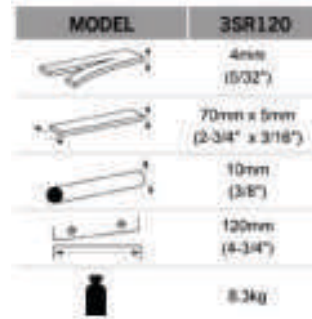

3SR120

€ 50



FI25

€ 112



FI35

€ 174



TV2676

€ 464

GUILHOTINA PARA VARÃO REDONDO Ø20
VARÃO QUADRADO 16 MM
BARRA DE 8MM



3SR120

€ 250

5SS506

€ 611

Peddinghaus



CHANFRADORA

CHANFRO ATÉ 15 MM
AJUSTE DE ÂNGULO CONTÍNUO DE 15 A 60°
IDEAL PARA CHAPAS E TUBOS
PESO 22 KG
PARA FERRO, INOX, ALUMÍNIO E METAIS NÃO FERROSOS
INCLUI CABEÇA DE FRESAGEM E 10 PASTILHAS
Ø MÍNIMO DOS TUBOS Ø160MM



SKF 025

€ 2.823

1100 WATTS - 230 V - 2850 RPM
FRESA MANDRIL ZFR 250
6 PASTILHAS SHM800

ACESSÓRIOS INCLUÍDOS



SERROTES DE DISCO



FOLHAS PARA SERROTES DE FITA - VÁRIOS TAMANHOS E VÁRIOS TIPOS DE DENTE - CONSULTE-NOS!



SERROTE DE DISCO

SERRA CIRCULAR MANUAL DE ESQUADRIA DUPLA
DISCO DE LÂMINA 250 MM.
CORTE DE ESQUADRIA BIDIRECIONAL (DE 0° A 45° À ESQUERDA E À DIREITA).
TORNO DE BLOQUEIO RÁPIDO COM FIXAÇÃO ANTI-REBARBAS.

€ 1.990

250 TECHNICS 380 V
2 VELOCIDADES DE CORTE

€ 1.890

250 TECHNICS 220 V
1 VELOCIDADE DE CORTE

TABELA DE CORTE

	○	□	▭	●
0°	75	65	90 x 50	40
+45°	65	60	80 x 50	35
-45°	60	60	80 x 50	35



SERROTE DE DISCO

SERRA CIRCULAR MANUAL DE ESQUADRIA DUPLA
DISCO DE LÂMINA 315 MM.
CORTE DE ESQUADRIA BIDIRECIONAL (DE 0° A 45° À ESQUERDA E À DIREITA).
TORNO DE BLOQUEIO RÁPIDO COM FIXAÇÃO ANTI-REBARBAS.

€ 3.230

SUPERCUTS315
380 V

TABELA DE CORTE

	○	□	▭	●
0°	95	80	100 x 70	80
+45°	80	75	80 x 70	70
-45°	80	75	80 x 70	70

SERROTES DE FITA

DESCIDA ASSISTIDA POR CILINDRO HIDRÁULICO
 380 V - DUAS VELOCIDADES
 INTERRUPTOR NO PUNHO
 FITA DE SERRA BIMETÁLICA 2085X20X0,9
 ESCALA MILIMÉTRICA
 0 A 60° À DIREITA
 BOMBA DE CIRCULAÇÃO DE LIQUIDO REFRIGERANTE

TABELA DE CORTE

	0°	45°	60°
	180	120	50
	180	110	50
	200x150	120x110	50x70

SERROTE DE FITA



ZIP 22 HB 380V
 AAT40000-3

€ 2.480



DESCIDA ASSISTIDA POR CILINDRO HIDRÁULICO
 380 V - DUAS VELOCIDADES
 INTERRUPTOR NO PUNHO
 FITA DE SERRA BIMETÁLICA 2450x27x0,9
 ESCALA MILIMÉTRICA
 0 A 60° À DIREITA
 BOMBA DE CIRCULAÇÃO DE LIQUIDO REFRIGERANTE

TABELA DE CORTE

	45°	0°	45°	60°
	120	225	140	60
	120	200	140	60
	110x140	240x140	135x150	60x85

ZIP 31 DA 380v

€ 3.990

SERROTE DE FITA



	0°	45°	60°
	225	140	60
	200	140	60
	240x140	135x150	60x85

ZIP 30 DA 380v

€ 3.290

AAZ10000-3



DESCIDA ASSISTIDA POR CILINDRO HIDRÁULICO
 380 V - DUAS VELOCIDADES
 INTERRUPTOR NO PUNHO
 FITA DE SERRA BIMETÁLICA 2750x27x0,9
 ESCALA MILIMÉTRICA
 0 A 60° À DIREITA
 BOMBA DE CIRCULAÇÃO DE LIQUIDO REFRIGERANTE

TABELA DE CORTE

	45°	0°	45°	60°
	160	255	200	110
	160	250	190	110
	190x100	300x220	190x170	110x130

SERROTE DE FITA



ZIP 32 DA 380V

€ 5.180

Código: AAV70000-3

SERROTES DE FITA

TRANSPORTADOR DE ROLOS

€ 1.400



Até 250 KG
COMPRIMENTO 2 MT
PARA SUPERTRAD 301
PARA LINHA 380



SERROTE DE FITA AUTOMÁTICO

DESCIDA ASSISTIDA POR CILINDRO HIDRÁULICO
380 V - DUAS VELOCIDADES
INTERRUPTOR NO PUNHO
FITA DE SERRA BIMETÁLICA M42 3310x27x0,9 MM
ESCALA MILIMÉTRICA



340 mm

SUPERTRAD 380
MULTIMODE AAS80000-3

TABELA DE CORTE

€ 12.190



45°	0°	45°	60°
220	300	260	180
180	260	250	170
200x160	330x260	270x200	170x170

SERROTE DE FITA AUTOMÁTICO

DESCIDA ASSISTIDA POR CILINDRO HIDRÁULICO
VELOCIDADE DA LÂMINA INFINITAMENTE VARIÁVEL
ATRAVÉS DE INVERTER DE 20 A 105 M/MIN
CICLO COMPLETO DE CORTE SEM OPERADOR
380 V - DUAS VELOCIDADES
INTERRUPTOR NO PUNHO
SERRA BIMETÁLICA M42
3310x27x0,9 MM
ESCALA MILIMÉTRICA
TOUCH SCREEN
AUTO-DIAGNÓSTICO



340 mm

SUPERTRAD 380
SO EASY AAV30000-3

€ 15.750



45°	0°	45°	60°
220	300	260	180
180	260	250	170
200x160	330x260	270x200	170x170



SERROTE DE FITA AUTOMÁTICO

THOMAS SUPER TRAD 370 AO CN EVOLUTION AAT10000-3

MÁQUINA DE SERRA DE FITA HORIZONTAL POTENTE
IDEAL PARA USO INTENSIVO REGULAR EM METAIS MAIS DUROS,
COMO FERRO E AÇO. AUTOMÁTICA.
CORTE DE ESQUADRIA SIMPLES 60° À DIREITA.
VELOCIDADE INFINITAMENTE VARIÁVEL DA LÂMINA
ATRAVÉS DO INVERSOR DE 20 A 105 M / MIN
CONTROLADOR TOUCH SCREEN COM CONTADOR
DE PEÇAS E HORAS DE TRABALHO.
EXIBIÇÃO DA VELOCIDADE DE ROTAÇÃO
DA LÂMINA (COM OPÇÃO INVERTER)
INTERFACE APP PARA TELEMÓVEL
FOLHA BIMETÁLICA M42 3240x27x0.91



€ 29.060

TABELA DE CORTE

	0°	45°	60°	
	300	270	170	355 mm
	260	260	150	
	350x260	270x200	170x150	



THOMAS SAR 480 SA GDS

MÁQUINA DE CORTE DE ALTA PERFORMANCE
HIDRÁULICO DE SUBIDA E DESCIDA
VELOCIDADE DE CORTE VARIÁVEL DE 20 A 105 M/MIN
LÂMINA BI METÁLICA M42 3810X28X0.9.
CORTE DE ESQUADRIA SIMPLES DE 0 60° À ESQUERDA
E 0 A 45° À DIREITA.
TENSÃO MECÂNICA DA LÂMINA
BOMBA ELÉCTRICA DE REFRIGERAÇÃO
BATENTE DE MEDIÇÃO
PARAGEM AUTOMÁTICA DO MOTOR NO FINAL DO CORTE
ABERTURA E FECHO AUTOMÁTICOS (OPCIONAL)



€ 14.470

	60°	45°	0°	45°	
	200	300	330	310	485 mm
	200	280	330	280	
	200x200	290x250	480x130	280x250	

SERROTES DE FITA

SERROTE DE FITA AUTOMÁTICO

SAR 610 SA DIGIT
AAM70000-3

€ 29.060

ESTRUTURA REFORÇADA EM AÇO, TOUCH SCREEN
HIDRÁULICO DE SUBIDA E DESCIDA
REGULADOR HIDRÁULICO PARA VELOCIDADE DE DESCIDA
VELOCIDADE DE CORTE VARIÁVEL DE 20 A 105 M/MIN
TECNOLOGIA INVERTER, CONTADOR DE PEÇAS
AJUSTE DA ALTURA DE CORTE, AUTO DIAGNÓSTICO
LAMINA BI METÁLICA M42
TENSÃO DA FOLHA COM MANÓMETRO
BOMBA ELÉCTRICA DE REFRIGERAÇÃO



5650x34x1,1



TABELA DE CORTE

	60°	45°	0°	45°	60°
	340	500	500	500	340
	320	450	500	450	320
	340x275	500x300	610x500	500x300	340x275



STH 1

	0°	45°	60°
	122	95	63
	122	95	63
	122x122	95x95	63x63

KW mt/min kg
1440x13x0,65 1,3 30/80 21 Kg



STH 2

	0°	45°	60°
	150	90	65
	140	90	65
	150x140	100x90	65x70

KW mt/min kg
1735x13x0,65 1,8-2,0 30/63 27 Kg



COM PEDESTAL
BASE INCLUÍDA

STH 3

	0°	45°	60°
	150	90	65
	140	90	65
	150x140	100x90	65x70

KW mt/min kg
1735x20x0,9 4,5 30/80 64 Kg

OPTIONAL
AAU60000-1

€ 650

OPTIONAL
AAU70000-1



€ 990

AA220000-1

€ 1.600



ENGENHOS PARA TODA A VIDA

ENGENHOS MAGNÉTICOS



TSA 30

AVANÇO MECÂNICO AUTOMÁTICO
 TRANSMISSÃO DE ENGRENAGEM
 MESA MÓVEL - CABEÇA FIXA
 AVANÇAR: 0.10-0..20 CONE CM3
 POTENCIA: 1.5/1.9 HP
 8 VELOCIDADES
 65 A 3060 RPM
 655x400x2100MM - 260 kG
 REFRIGERAÇÃO: OPCIONAL

TSA.30 € 7.360



TCE 50

AVANÇO MECÂNICO AUTOMÁTICO
 EMBRAIAGEM ELECTROMAGNÉTICA
 TRANSMISSÃO DE ENGRENAGEM
 MESA MÓVEL - CABEÇA FIXA
 AVANÇAR: 0.10-0..20-0.30-0.40
 POTENCIA: 4 HP
 9 VELOCIDADES
 54 A 3060 RPM - CONE CM4
 REFRIGERAÇÃO INCLUÍDA

TCE.50 € 15.590

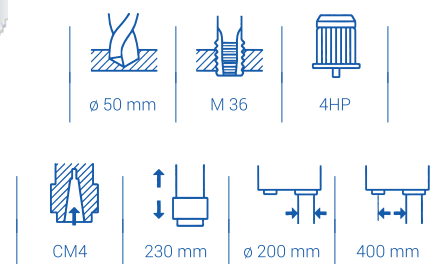

Drills / Units / CNC



TSA 40

AVANÇO MECÂNICO AUTOMÁTICO
 EMBRAIAGEM MECÂNICA
 TRANSMISSÃO DE ENGRENAGEM
 MESA MÓVEL - CABEÇA FIXA
 AVANÇAR: 0.10-0.18-0.24
 POTENCIA: 2 HP - CONE CM4
 8 VELOCIDADES
 93 A 1420 RPM
 755x480x2265MM - 435 kG
 REFRIGERAÇÃO INCLUÍDA

TSA.40 € 9.590

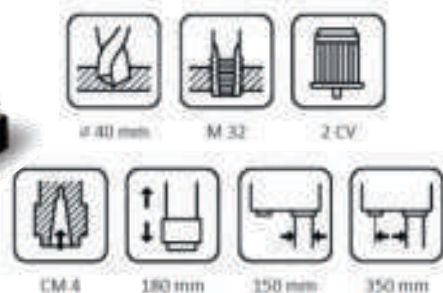

GP 32

AVANÇO MECÂNICO AUTOMÁTICO
 TRANSMISSÃO DE ENGRENAGEM
 MESA MÓVEL - CABEÇA FIXA
 AVANÇAR: 0.10-0.20-0.30 CONE Cm3
 POTÊNCIA: 2/3 HP
 8 VELOCIDADES
 65 A 3060 RPM
 655X400X2100 MM- 260 KG
 REFRIGERAÇÃO INCLUÍDA

GP.32 € 6.890

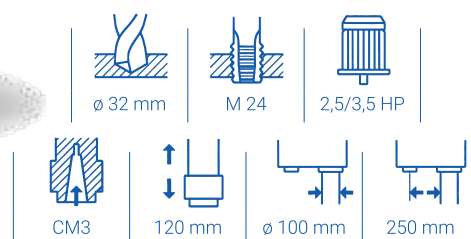

ENGENHOS DE FURAR MAGNÉTICOS

BDSMASCHINEN
MADE IN GERMANY



ProfiPLUS



MAB 825

€ 3.040

1800 WATT - 230 V - ROSCA ATÉ M30
FURA ATÉ 110MM COM BROCA MAX Ø100 HSS/TCT
FURA ATÉ Ø32 COM BROCA HELICOIDAL
ESCAREAMENTO ATÉ Ø50
255MM CURSO SUBIDA DESCIDA DE CABEÇOTE
25 KG - CONE Mt3 - MANDRIL 32MM WELDON 1 1/4'
COM BUCHA WELDON 19MM 3/4' MANUAL
4 VELOCIDADES DE ENGRENAGEM
LUBRIFICAÇÃO INTERNA PERMANENTE
EMBLEAGEM DE SEGURANÇA
ROTAÇÃO NOS DOIS SENTIDOS
CONTROLO DE DESGASTE DAS ESCOVAS
PROTEÇÃO CONTRA AQUECIMENTO

ACESSÓRIOS INCLUÍDOS



BDS
MASCHINEN



ProfiPLUS



MAB 1300

€ 5.558

BDSMASCHINEN
MADE IN GERMANY

2300 WATT - 230 V - ROSCA ATÉ M42
FURA ATÉ 110MM COM BROCA MAX Ø130 HSS/TCT
FURA ATÉ Ø45 COM BROCA HELICOIDAL
ESCAREAMENTO ATÉ Ø80
310MM CURSO SUBIDA DESCIDA DE CABEÇOTE
51 KG - CONE MT4 - MANDRIL 32MM WELDON 1 1/4'
4 VELOCIDADES DE ENGRENAGEM
LUBRIFICAÇÃO INTERNA PERMANENTE
EMBLEAGEM DE SEGURANÇA
ROTAÇÃO NOS DOIS SENTIDOS
CONTROLO DE DESGASTE DAS ESCOVAS
PROTEÇÃO CONTRA AQUECIMENTO

ACESSÓRIOS INCLUÍDOS





ENGENHOS DE FURAR MAGNÉTICOS



ENGENHO AUTOMÁTICO

1050 WATT - 230 V - COM INDICADOR MAGNÉTICO
 FURA ATÉ 55MM COM BROCA MAX Ø35HSS/TCT
 150MM CURSO SUBIDA DESCIDA DE CABEÇOTE
 15 KG - 1 VELOCIDADE
 COM BUCHA WELDON 19MM 3/4' KEYLESS
 LUBRIFICAÇÃO INTERNA PERMANENTE
 PERFURAÇÃO AUTOMÁTICA
 REVERSÃO E OFF AUTOMÁTICOS
 DEPÓSITO PARA LIQUIDO DE ARREFECIMENTO
 1 VELOCIDADE DE ENGRENAGEM



ACESSÓRIOS INCLUÍDOS



AUTOMAB 350

€ 1.490



ENGENHO COMPLETAMENTE AUTOMÁTICO



1150 WATT - 230 V - COM INDICADOR MAGNÉTICO
 FURA ATÉ 55MM COM BROCA MAX Ø45HSS/TCT
 150MM CURSO SUBIDA DESCIDA DE CABEÇOTE
 16 KG - 1 VELOCIDADE - CONE MT2
 COM BUCHA WELDON 19MM 3/4' KEYLESS
 LUBRIFICAÇÃO INTERNA PERMANENTE
 PERFURAÇÃO AUTOMÁTICA
 REVERSÃO E OFF AUTOMÁTICOS
 DEPÓSITO PARA LIQUIDO DE ARREFECIMENTO
 2 VELOCIDADES DE ENGRENAGEM



ACESSÓRIOS INCLUÍDOS



AUTOMAB 450

€ 1.948

ENGENHOS MAGNÉTICOS

BDSMASCHINEN
MADE IN GERMANY

ENGENHO DE BASE MAGNÉTICA

ProfiBASIC



900 WATT - 230 V
FURA ATÉ 55MM COM BROCA MAX Ø32HSS/TCT
COM BROCA HELICOIDAL ATÉ Ø13
160MM CURSO SUBIDA DESCIDA DE CABEÇOTE
12 KG - 1 VELOCIDADE
COM BUCHA WELDON 19MM 3/4' KEYLESS
LUBRIFICAÇÃO INTERNA PERMANENTE
DEPÓSITO PARA LIQUIDO DE ARREFECIMENTO



MABASIC 200

€ 863

ACESSÓRIOS INCLUÍDOS



BDSMASCHINEN
MADE IN GERMANY

ENGENHO DE BASE MAGNÉTICA

ProfiBASIC



1050 WATT - 230 V
FURA ATÉ 55MM COM BROCA MAX Ø32HSS/TCT
COM BROCA HELICOIDAL ATÉ Ø16
160MM CURSO SUBIDA DESCIDA DE CABEÇOTE
12 KG - 2 VELOCIDADES - 430/760 RPM
COM BUCHA WELDON 19MM 3/4' KEYLESS
LUBRIFICAÇÃO INTERNA PERMANENTE
DEPÓSITO PARA LIQUIDO DE ARREFECIMENTO



MABASIC 200

€ 1.130

ACESSÓRIOS INCLUÍDOS



BROCAS

HSS-Co 8 Core drill short

- > 30 mm Cutting depth
- > 19 mm Weldon shank (3/4")



Ø mm	Order no.	€/u	Ø mm	Order no.	€/u
12	KBK-CO 012	24,30 €	36	KBK-CO 036	72,30 €
13	KBK-CO 013	25,30 €	37	KBK-CO 037	73,50 €
14	KBK-CO 014	23,50 €	38	KBK-CO 038	74,50 €
15	KBK-CO 015	27,30 €	39	KBK-CO 039	76,30 €
16	KBK-CO 016	28,30 €	40	KBK-CO 040	79,30 €
17	KBK-CO 017	29,00 €	41	KBK-CO 041	83,30 €
17,5	KBK-CO 175	29,80 €	42	KBK-CO 042	87,00 €
18	KBK-CO 018	26,80 €	43	KBK-CO 043	89,80 €
19	KBK-CO 019	30,50 €	44	KBK-CO 044	95,00 €
19,5	KBK-CO 195	31,00 €	45	KBK-CO 045	98,30 €
20	KBK-CO 020	32,50 €	46	KBK-CO 046	100,80 €
21	KBK-CO 021	34,00 €	47	KBK-CO 047	103,80 €
22	KBK-CO 022	33,50 €	48	KBK-CO 048	105,30 €
23	KBK-CO 023	36,80 €	49	KBK-CO 049	108,30 €
24	KBK-CO 024	38,00 €	50	KBK-CO 050	112,30 €
25	KBK-CO 025	40,50 €	51	KBK-CO 051	119,30 €
26	KBK-CO 026	39,80 €	52	KBK-CO 052	125,00 €
27	KBK-CO 027	43,00 €	53	KBK-CO 053	139,50 €
28	KBK-CO 028	44,00 €	54	KBK-CO 054	141,30 €
29	KBK-CO 029	45,00 €	55	KBK-CO 055	142,50 €
30	KBK-CO 030	48,50 €	56	KBK-CO 056	143,50 €
31	KBK-CO 031	50,00 €	57	KBK-CO 057	144,50 €
32	KBK-CO 032	51,00 €	58	KBK-CO 058	145,00 €
33	KBK-CO 033	53,30 €	59	KBK-CO 059	146,30 €
34	KBK-CO 034	61,80 €	60	KBK-CO 060	146,80 €
35	KBK-CO 035	68,50 €			

HSS-Co 8 Core drill short

- > 30 mm Cutting depth
- > 32 mm Weldon shank (1 1/4")



Ø mm	Order no.	€/u	Ø mm	Order no.	€/u
61	KBK-CO 061	147,80 €	84	KBK-CO 084	199,80 €
62	KBK-CO 062	148,50 €	85	KBK-CO 085	201,80 €
63	KBK-CO 063	149,80 €	86	KBK-CO 086	205,30 €
64	KBK-CO 064	150,50 €	87	KBK-CO 087	208,30 €
65	KBK-CO 065	151,50 €	88	KBK-CO 088	212,30 €
66	KBK-CO 066	152,50 €	89	KBK-CO 089	215,50 €
67	KBK-CO 067	153,50 €	90	KBK-CO 090	217,00 €
68	KBK-CO 068	153,80 €	91	KBK-CO 091	220,30 €
69	KBK-CO 069	155,50 €	92	KBK-CO 092	223,50 €
70	KBK-CO 070	158,00 €	93	KBK-CO 093	226,00 €
71	KBK-CO 071	161,50 €	94	KBK-CO 094	228,50 €
72	KBK-CO 072	165,50 €	95	KBK-CO 095	231,00 €
73	KBK-CO 073	168,50 €	96	KBK-CO 096	233,80 €
74	KBK-CO 074	170,50 €	97	KBK-CO 097	236,50 €
75	KBK-CO 075	173,80 €	98	KBK-CO 098	239,50 €
76	KBK-CO 076	177,00 €	99	KBK-CO 099	242,50 €
77	KBK-CO 077	180,50 €	100	KBK-CO 100	247,30 €
78	KBK-CO 078	183,00 €	105	KBK-CO 105	255,30 €
79	KBK-CO 079	185,80 €	110	KBK-CO 110	267,30 €
80	KBK-CO 080	189,00 €	115	KBK-CO 115	275,00 €
81	KBK-CO 081	191,00 €	120	KBK-CO 120	282,80 €
82	KBK-CO 082	194,00 €	125	KBK-CO 125	291,00 €
83	KBK-CO 083	196,80 €	130	KBK-CO 130	297,00 €

Ejector pin for KBK-CO, Ø 12-60 mm	
Order no.	€/u
ZAK 075	5,30 €
Ejector pin for KBK-CO, Ø 61-130 mm	
Order no.	€/u
ZAK 090	6,30 €



PROFISSIONAL
1-10X0.5 MM
19 PCS



01016401

€ 11,99

INDUSTRIAL
1-10X0.5 MM
19 PCS



01068401

€ 32,3

COBALTO 8%
1-10X0.5 MM
19 PCS



01135401

€ 69

22-29-35-44-51-64
6 PCS
ELECTRICISTA



21080201K

€ 61



610 pcs Ø 1-13 x 0,5 mm

Ø	pcs	Ø	pcs
1	30	7,5	5
1,5	50	8	10
2	50	8,5	5
2,5	50	9	5
3	100	9,5	5
3,5	50	10	10
4	100	10,5	5
4,5	30	11	5
5	30	11,5	5
5,5	10	12	5
6	20	12,5	5
6,5	10	13	5
7	10		

01016510

€ 289

ENGENHOS DIVERSOS



COLUNA ALTA

MOTOR 0.5 HP
ALIMENTAÇÃO 380V
BUCHA 16 MM
COLUNA D. 73 MM
VELOCIDADE - 180-2740 RPM
ENCAVADOR MT2
ALTURA 1620 MM
PESO 57 KG

DP34016F € 380

MEIA COLUNA

MOTOR 0.5 HP
ALIMENTAÇÃO 220V
BUCHA 16 MM
COLUNA D. 73 MM
VELOCIDADE - 180-2740 RPM
ENCAVADOR MT2
ALTURA 1080 MM
PESO 52 KG

DP34016B € 320



COLUNA ALTA

MOTOR 1.5 HP
ALIMENTAÇÃO 380V
BUCHA 25 MM
COLUNA D. 92 MM
VELOCIDADE - 120-3480 RPM
ENCAVADOR MT2
ALTURA 1640 MM
PESO 144 KG

DP51025F

€ 830



MODELO ZX40PC ENGENHO SEM MESA DE FRESAGEM E SEM DESCIDA AUTOMÁTICA

ZS40PS

€ 3.100



MESA DE FRESAR

ZX7025A

€ 455

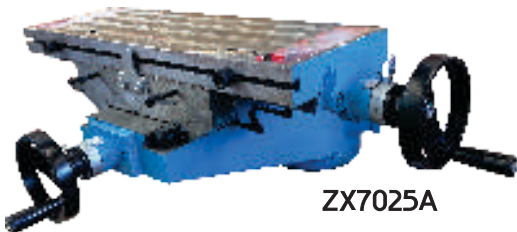

MESA MARCA BEERGMAN
MEDIDA DA MESA - 640X205
DESLOCAMENTO LONGITUDINAL 370 MM
DESLOCAMENTO TRANSVERSAL 150 MM
DIMENSÕES BASE (MM) 238X320
PESO (KGS) 60

ENGENHO COM MESA E REGRIGERAÇÃO

MEDIDA MESA FRESAR 585X190
MOTOR (HP) 1
Nº VELOCIDADES FURAÇÃO 6-95~1600
CAPACIDADE FURO 40 MM
Ø COLUNA 115 MM
DISTÂNCIA PONTO BASE 1245 MM
ALTURA (MM) 1810
PESO (KGS) 375
COM DESCIDA E RECUO AUTOMÁTICO

ZX40BPC

€ 3.490





ACESSÓRIOS PARA METALOMECÂNICA



TORNOS DE BANCADA



M/90 - 100 MM € 100

FZA MONDIAL

M/91 - 125 MM € 121

M/92 - 150 MM € 171

M/93 - 175 MM € 276

Cod.	Larghezza ganasce Largeur des mâchoires Jaws width Backenbreite Anchura de boca	Apertura Ouverture Opening Spannweite Apertura	kg
M/90	100	125	7,0
M/91	125	150	11,0
M/92	150	200	17,0
M/93	175	220	26,0



SEM VIBRAÇÃO - PROTECÇÃO TÉRMICA
ATÉ DEZ ANOS DE GARANTIA

S-125 € 200

S-200 M € 315

S-150 € 210

S-200 T € 342



Art.		Hp	W	RPM	MOLA	PESO NETTO	PESO LORDO Bancale	DIMENSIONI cm	
S-125*	SERIE SPECIAL	0,35	1~	260	2800	125X16X20	7,1	8,1	32X22X26
S-150*		0,50	1~	375	2800	150X20X20	9,3	10,3	35x23x29
S-200M		0,90	1~	675	2800	200x25x16/20	17,6	18,6	45x30x34
S-200T		1,00	3~	750	2800	200x25x16/20	17,6	18,6	45x30x34

ACESSÓRIOS PARA METALOMECÂNICA



VESPA

VSA/C24 - 5MT TUBO ABRASIVO Ø 25
 PORTA BICO - PORTA BORRACHA
 BICO DE CARBONETO EM TUNGSTÊNIO Ø 4 x 40

206.024 - 24 LITROS

€ 1.890

VSA/C80 (10 MTS TUBO) OU VSA/C200 (20 MTS TUBO)
 ABRASIVO Ø 40 - PORTA BICO - PORTA BORRACHA
 BICO DE CARBONETO EM TUNGSTÊNIO Ø 7 x 75 OU Ø 8 x 75

206.080 - 80 LITROS

€ 3.380

206.200 - 200 LITROS

€ 4.116



PANDA



DECAPAGEM DE BAIXA PRESSÃO - 24 LITROS
 IDEAL PARA RESTAUROS
 MANGUEIRA DE ABRASIVO Ø 25, 5 METROS COM PORTA-MANGUEIRA
 PORTA-BICO COM PORCA DE ANEL E BICO DE TUNGSTÊNIO Ø 4 X 40.
 1,5 A 12 BAR - FUNCIONA COM DIVERSOS TIPOS DE ABRASIVO:
 MICROESFERAS DE VIDRO, BICARBONATO DE SÓDIO PARA REMOÇÃO
 DE TINTAS E LIMPEZA, ABRASIVOS VEGETAIS (CASCA DE NOZ
 MOÍDA, SABUGO), AREIA DE SÍLICA (NÃO PERMITIDA EM EDIFÍCIOS
 PÚBLICOS) E GRÃOS DE METAL

205-102 PANDA/C 24

€ 3.350

CAPACETE PROTEÇÃO VRC 4



300010

€ 190



PROTECÇÃO DO OPERADOR



300040

€ 570

CAPACETE C/FATO
 VESPA VACS 952

CAPACETE C/FATO
 VESPA VACS 951

300030

€ 540



PUNCIÓNADORAS MULTI



PUNCIÓNADORA UNIVERSAL



MAIS PRODUTIVIDADE COM DISTÂNCIA AJUSTÁVEL DO CURSO DO PISTÃO
SISTEMA DE LUBRIFICAÇÃO CENTRAL
CINCO ESTAÇÕES DE TRABALHO INDIVIDUAIS NA MÁQUINA
PUNÇÃO E MATRIZ DE Ø22 MM E FERRAMENTAS PERFURADORAS PADRÃO
CONJUNTO DE LÂMINAS DE CORTE DE BARRAS REDONDAS E QUADRADAS
ONJUNTO DE LÂMINAS DE CORTE ANGULAR
TESOURA DE CORTE DE CHAPA
CONJUNTO DE LÂMINAS U-NOTCHING
60 TON

HKM 60

€ 11.500

INCLUI 6 PUNÇÃO + MATRIZES REDONDAS
EM MEDIDAS A ESCOLHER ATÉ 22 MM



**PUNCIÓNADORA UNIVERSAL DUPLO PISTON
2 POSTOS DE TRABALHO**

MAIS PRODUTIVIDADE COM DISTÂNCIA AJUSTÁVEL DO CURSO DO PISTÃO
SISTEMA DE LUBRIFICAÇÃO CENTRAL
CINCO ESTAÇÕES DE TRABALHO INDIVIDUAIS NA MÁQUINA
PUNÇÃO E MATRIZ DE Ø22 MM E FERRAMENTAS PERFURADORAS PADRÃO
CONJUNTO DE LÂMINAS DE CORTE DE BARRAS REDONDAS E QUADRADAS
CONJUNTO DE LÂMINAS DE CORTE ANGULAR
TESOURA DE CORTE DE CHAPA
CONJUNTO DE LÂMINAS U-NOTCHING
85 TON

HKM 85

€ 24.900

INCLUI 6 PUNÇÃO + MATRIZES REDONDAS
EM MEDIDAS A ESCOLHER ATÉ 22 MM



TORNOS MECÂNICOS

BUCHA 3 GRAMPOS 250 MM
LUNETTA FIXA
LUNETTA MÓVEL
PONTO ROTATIVO
TORRETA RÁPIDA TIPO B
PEDAL DE EMERGÊNCIA
FURO ÁRVORE 62 MM

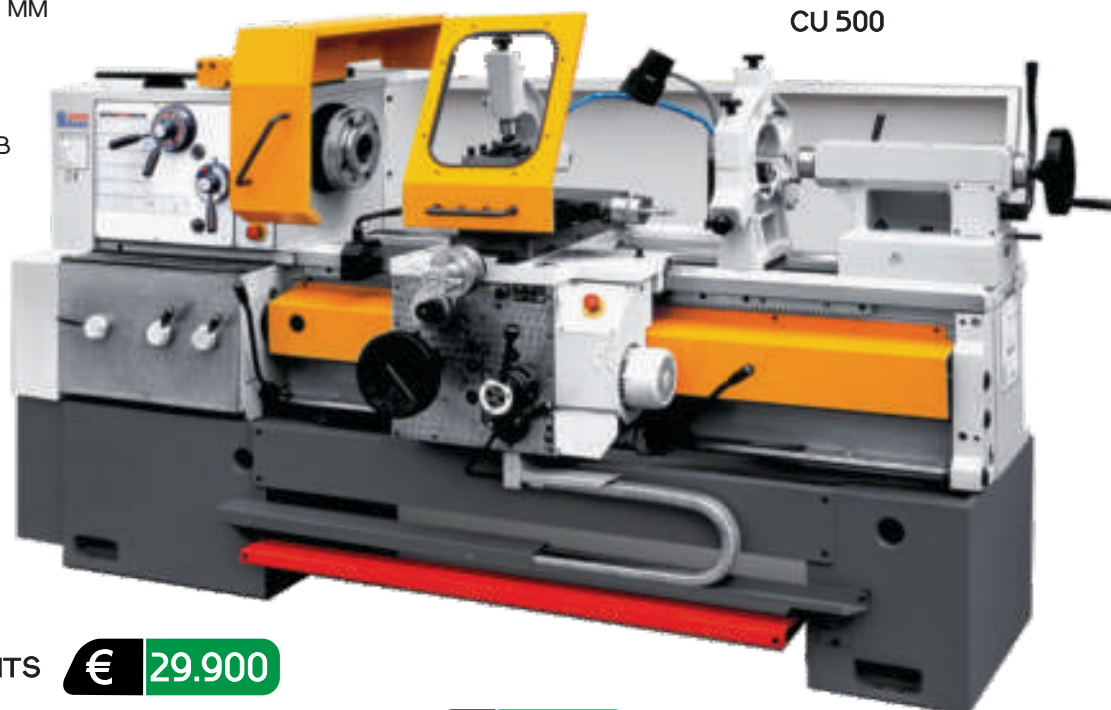

CU 500

CU 500 - 1.5 MTS € 29.900

CU 500 - 2 MTS € 30.490



CU 580

CU 580 M - 1.5 MTS € 31.500

CU 580 M - 2 MTS € 32.500

BUCHA 3 GRAMPOS 250 MM, LUNETTA FIXA
LUNETTA MÓVEL, PONTO ROTATIVO
TORRETA RÁPIDA TIPO B, PEDAL DE EMERGÊNCIA
FURO ÁRVORE 72 MM

CU 580 M - 3 MTS € 36.400

TORNOS MECÂNICOS

CU 630

3 GRAMPOS 315 MM, LUNETAS FIXA
LUNETAS MÓVEL, PONTO ROTATIVO
TORRETA RÁPIDA TIPO C
PEDAL DE EMERGÊNCIA
FURO ÁRVORE 103 MM



CU 630 - 3 MTS

€ 38.900

Helper
MAQUINARIA / MACHINERY

Helper
MAQUINARIA / MACHINERY



Ø MAX EXTERNO 460 MM
Ø MAX COM CARRO 274 MM
DISTÂNCIA ENTRE PONTOS 1500 MM
LARGURA DA BANCADA 300 MM
CAMLOCK D1-8
SPINDLE CM6 - 12 VELOC. (25-2000 RPM)
CONTRA PONTO CM4

T460x1500

€ 21.990

INCLUI: BUCHA DE 3 GARRAS Ø250, BUCHA 4 GARRAS Ø320, DIGITAL 2 EIXOS, CONE REDUTOR CM6 A CM4, INDICADOR DE ROSCAS, TORRETA DE TROCA RÁPIDA, LUNETAS FIXAS, LUNETAS MÓVEIS, SISTEMA DE REFRIGERAÇÃO 2 PONTOS FIXOS, CALÇOS DE NIVELAMENTO, LÂMPADA, CAIXA DE FERRAMENTA, CERTIFICADO CE

MANDRILADORA E FRESADORA



MANDRILADORA PORTÁTIL MULTIFUNÇÕES
SUPERCOMBINATA EASY



TRABALHO EM Ø 32 A Ø 250
EQUIPADA COM MOTOR DE 1800 W
2 VELOCIDADES - 120 E 400 RPM
TODA A LINHA DOS EQUIPAMENTOS ELSA
SÃO COMPATÍVEIS COM QUALQUER MÁQUINA
DE SOLDAR MIG/MAG DE LIGAÇÃO EURO

SC140/1-E € 15.600

HELLER

FRESADORA VERTICAL DE TORRETA FTV 3



DIGITAL FAGOR X,Y,Z
MESA 1370 X 254 COM 3 RANHURAS 16MM
PESO MAX NA MESA: 340 KG
EIXO X - 840 MM
EIXO Y - 380 MM
EIXO Z - 325 MM MOTORIZADO
VARIADOR DE VELOCIDADES 60-4200 RPM
POTENCIA 3.75 kW
PINÇA PNEUMÁTICA - CONE ISO40
GUIAS TEMPERADAS
LUBRIFICAÇÃO AUTOMÁTICA
GRUPO DE REFRIGERAÇÃO
ROTAÇÃO DO CABEÇOTE

FTV 3

€ 21.000

Otimizamos a sua produção ao máximo



FomGroup

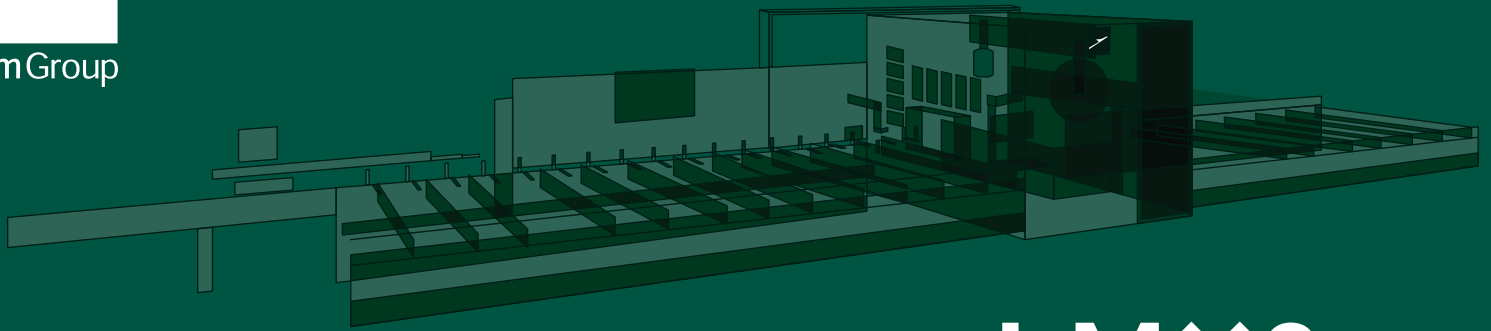

LMX2
650

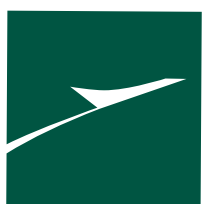

FomIndustrie
Aluminium Working Machinery





INCLUI SOFTWARE DE CORTE DE MEDIDAS ESPECIAIS, MEDIDOR DE ALTURA DE PERFIL E SISTEMACORTE PASSO A PASSO

MÁQUINAS PARA ALUMÍNIO

SERRA DE DUAS CABEÇAS PARA CORTE DE ALUMINIO
BLITZ ALVA 500



SERROTE DE DUAS CABEÇAS COM LÂMINAS DE CARBONETO DE TUNGSTÊNIO Ø 500 MM COM MOVIMENTO MOTORIZADO DO CABEÇOTE MÓVEL E CONTROLO ELECTRO-PNEUMÁTICO DA INCLINAÇÃO DO CABEÇOTE.
DISPONÍVEL VERSÕES DE 4 - 5 E 6 METROS

XZ-10784 - 4 METROS € 27.990



€ SOB CONSULTA

BLITZ65

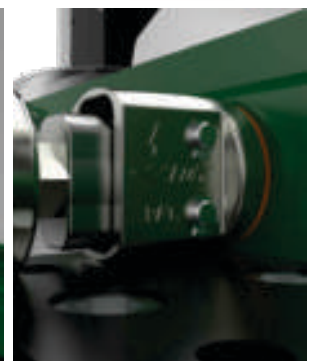
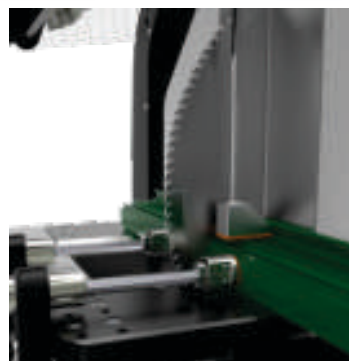
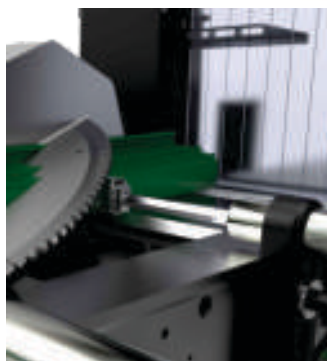

MÁQUINAS PARA ALUMÍNIO



**PANTÓGRAFO ELECTROPNEUMÁTICO
P/ ALUMÍNIO E PVC**

CALCO

- ACOPLAMENTO DE FERRAMENTA ER 16
- 2 MORSAS HORIZONTAIS COM VÁLVULAS DE SEGURANÇA
- SISTEMA DE LUBRIFICAÇÃO DE LÂMINA POR PULVERIZAÇÃO
- MARCADOR PNEUMÁTICO COM SELETOR DE DIÂMETRO DUPLO DE Ø 5 E Ø 8 MM
- MOTOR TRIFÁSICO DE 0,75 KW 230/400 V - 50 HZ
- FILTRO DE AR, BROCA DE FRESA: Ø 8 MM - 8 MM TANG
- PINÇA ER 16 PARA BROCA DE FRESAGEM: Ø 8 MM
- 2 PLACAS GABARITOS

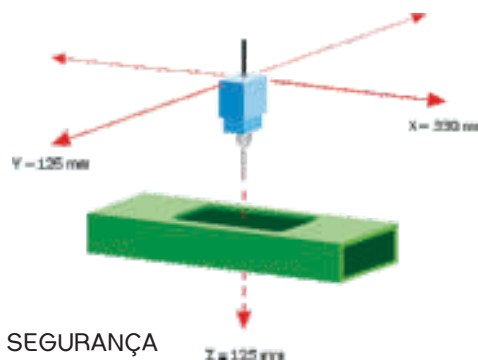

XX11145

€ 2.900



EMALHETADEIRA PNEUMÁTICA JET

- ÂNGULO DE FRESAGEM DE TOPO DE 90°
- VELOCIDADE DA UNIDADE DA FERRAMENTA DE FRESAGEM 2800 RPM
- TAMANHO MÁX. DA FERRAMENTA DE FRESAGEM Ø 130 MM
- SISTEMA DE BALANCEAMENTO DA UNIDADE DE FERRAMENTA DE FRESAGEM
- ARMAZÉM DE CORTADORES COM 3 CAIXAS
- SISTEMA DE LUBRIFICAÇÃO DE LÂMINA POR PULVERIZAÇÃO
- PERCURSO CARRO: X MAX = 244 MM
- PROFUNDIDADE DE FRESAGEM: Y MAX = 44 MM
- ALTURA MÁXIMA DA UNIDADE DE FRESAGEM: Z = 125 MM
- ALTURA DO TAMPO 852 MM
- PREPARADO PARA EXTRACÇÃO DE LIMALHAS E GASES
- TRAVA DE ABERTURA DE SEGURANÇA
- PRESSÃO DE TRABALHO DUPLA SERVOCONTROLADA EM BAIXA PRESSÃO
- INCLUI: LUVA DE CORTE PARA UNIDADES DE FRESAGEM
- MORSAS HORIZONTAIS E VERTICAIS

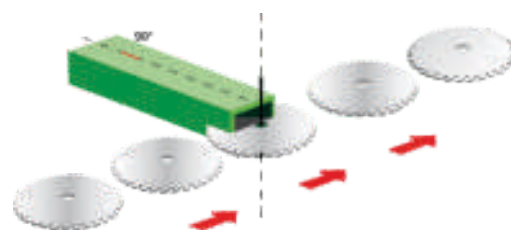

XX11068

€ 2.800

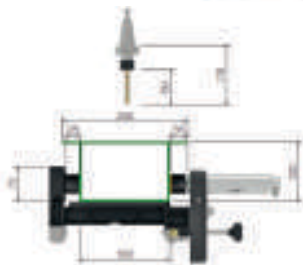

INCLUI:

- 4 MORSAS PNEUMÁTICAS DE POSICIONAMENTO MANUAL - PR204832
- CARROSSEL DE 5 POSIÇÕES COM MUDANÇA DE FERRAMENTA AUTOMÁTICA - PR204851
- MESA COM POSICIONADOR MANUAL DE ÂNGULOS INTERMÉDIOS - PR28965
- MODULO 2D PARA FSTCAM4 - Zp714617
- KIT FERRAMENTAS DE ALUMÍNIO TIPO 1 - PR27602

Xx100329

€ 49.700

VÁRIOS OPCIONAIS DE OTIMIZAÇÃO DISPONÍVEIS
 TROCA AUTOMÁTICA DE FERRAMENTA
 BOMBA DE ÁGUA DE LUBRIFICAÇÃO
 ROTAÇÃO AJUSTÁVEL DA MESA PARA
 ÂNGULOS INTERMÉDIOS



CENTRO DE MAQUINAÇÃO FMC - 470

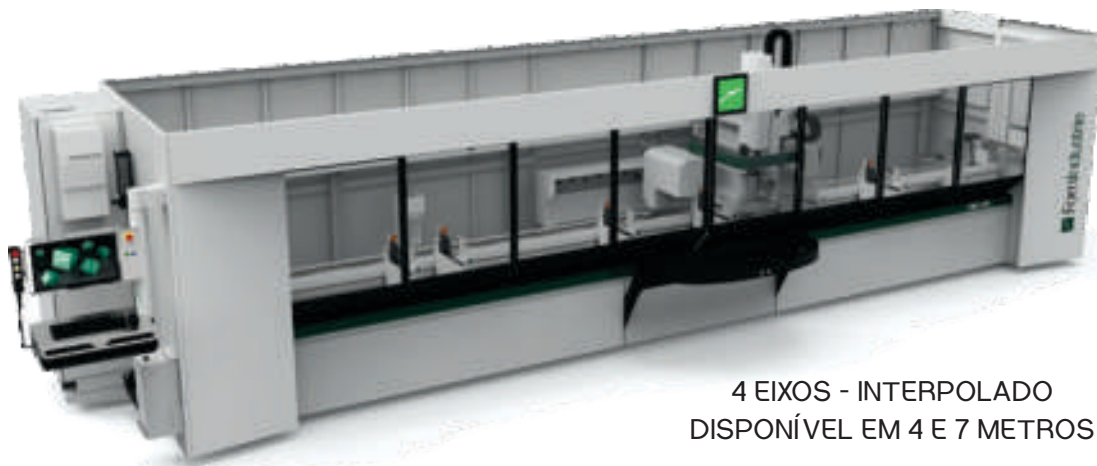
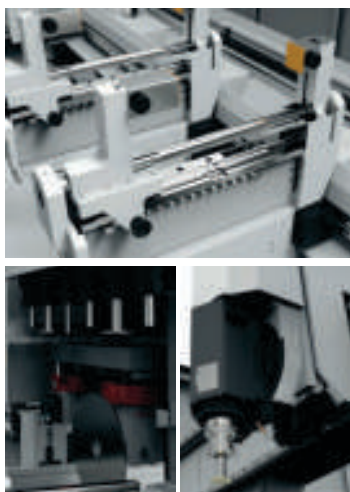

4 EIXOS - INTERPOLADO
DISPONÍVEL EM 4 E 7 METROS

SPINDLE DE 7 KW REFRIGERADO A ÁGUA
 20000 RPM MAX
 4 EIXOS DE MAQUINAÇÃO
 DIREÇÃO DO LUBRIFICANTE AUTOMÁTICA - XFLOW
 2 ZONAS DE TRABALHO
 CARROSSEL DE 9 POSIÇÕES + 8 OPCIONAIS

2 BATENTES PNEUMÁTICOS AUTOMÁTICOS
 MEDIDOR DE COMPRIMENTO DE PERFIL AUTOMÁTICO
 ATÉ 8 MORSAS - 4 POR ÁREA DE TRABALHO
 CHASSIS ROBUSTO PATENTEADO
 CONSOLA DE CONTROLO AJUSTÁVEL
 COMANDO DE CONTROLO PORTÁTIL
 LEDS INDICADORES DE TRABALHO

PREÇO SOB CONSULTA

MÁQUINAS PARA ALUMÍNIO



SPRING 45 E

REV. ✓
17/01/2022

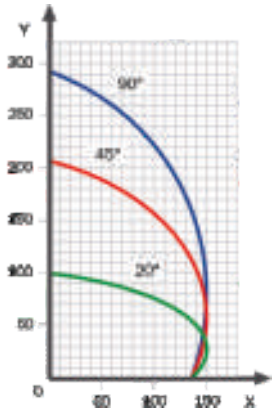
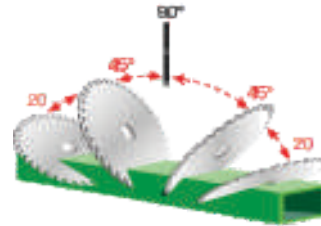

MÁQUINA DE CORTE DE CABEÇOTE SIMPLES DE Ø 450 MM COM AVANÇO DO DISCO DE TRÁS PARA FRENTE MOVIMENTO FRONTAL COM INCLINAÇÃO PNEUMÁTICA DE 20° A 90° ESQUERDA E DIREITA COM PROTECÇÃO FRONTAL

Xz10677

€ **8.400**



SPEEDY WORK

MESA DE ROLOS COM POSICIONAMENTO MANUAL CAPACIDADE DE CARGA KG. 3 POR METRO BATENTE DE ACERTO MANUAL DISPONÍVEL NAS VERSÕES DE 3 E 4,2 METROS

XK201566 € **855** 3 MTS

XK201567 € **970** 4 MTS



ASSOMAK

MESA DE ROLOS COM POSICIONAMENTO AUTOMÁTICO CAPACIDADE DE CARGA KG. 3 POR METRO BATENTE DE ACERTO PNEUMÁTICO DISPONÍVEL NAS VERSÕES DE 3 - 4,2 E 6 METROS

XK100160 € **1.720** 3 MTS

XK100168 € **1.935** 4.2 MTS

XK100170 € **2.430** 6 MTS



MÁQUINAS PARA ALUMÍNIO

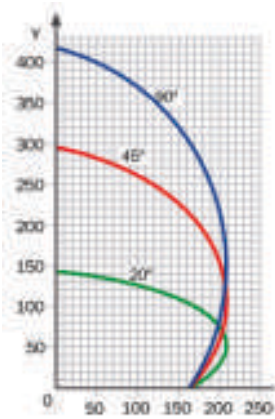

REV. ✓
17/01/2022

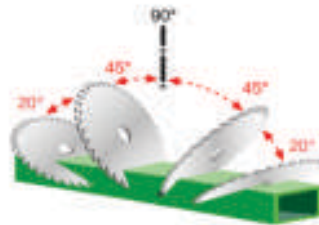

SPRING 55



MÁQUINA DE CORTE DE DE LÂMINA FRONTAL DE Ø 550 MM
CONTROLE ELETROPNEUMÁTICO DA INCLINAÇÃO DA CABEÇA
DE 20° A 90° ESQUERDA E DIREITA
SISTEMA DE LUBRIFICAÇÃO DE LÂMINA

XZ10304

€ 15.050



DISPONÍVEL NAS VERSÕES PNEUMÁTICA E MANUAL

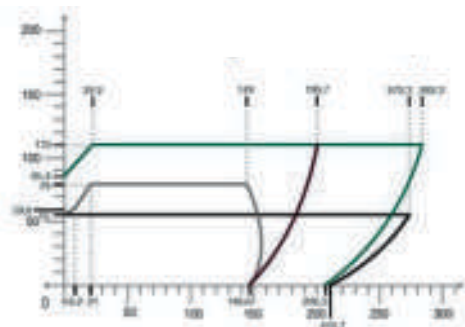

SIKA PLUS MANUAL

400 V - 2.2 KW



LÂMINA DE CORTE DE TUNGSTÊNIO Ø 400 MM
KIT DE PROTEÇÃO DE ÁREA DE CORTE INTEGRAL
2 TORNOS PNEUMÁTICOS HORIZONTAIS
LUBRIFICAÇÃO DE FERRAMENTA
PREPARADO PARA EXTRACÇÃO DE LIMALHAS E FUMOS
ÂNGULOS INTERMÉDIOS COM BATENTE MECÂNICO
ÂNGULO DE CORTE LD A 45° E LE A 45° NO EIXO VERTICAL

XZ100228

€ 4.400

MÁQUINAS PARA ALUMINIO E PVC

PINÇA DE 8MM

4 APERTOS PNEUMÁTICOS

3 COPIADORES DE 3 DIAMETROS: 5/8/10MM

5 BATENTES DE REGULAÇÃO

3 CHAPAS COPIADORAS STANDARD

LUBRIFICAÇÃO PNEUMÁTICA

FILTRO DE AR

PISTOLA DE AR

Mepal Italia

EGO3000

COPY ROUTER

€ 14.990



PANTÓGRAFO AUTOMÁTICO
COM MESA ROTATIVA

CENTRO DE FRESAGEM MANUAL A 3 EIXOS C/ LUBRIFICAÇÃO PNEUMÁTICA E 3 COPIADORES PNEUMÁTICOS. DOTADO DE MESA PNEUMÁTICA GIRATÓRIA -90°/0°/+90° COM ESCALA PARA A REGULAÇÃO DOS GRAUS INTERMÉDIOS. SISTEMA FÁCIL E RÁPIDO NO POSICIONAMENTO DOS COPIADORES. EQUIPADO COM UM SPINDLE C/VELOCIDADE VARIÁVEL QUE PODE IR DE 2800 A 12000 RPM, COM MOTOR TRIFÁSICO 1,1 kW. CAPACIDADE DE TRABALHO A 0° É DE 3000X250X200MM. MOVIMENTO EIXO X EM GUIAS LINEARES. MÁQUINA INDICADA PARA TRABALHAR ALUMINIO, PVC, AÇO INOX E FERRO.

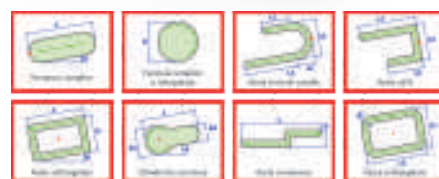

profteQ
made in Italy evolution on pvc windows

profteQ
made in Italy evolution on pvc windows

SOLDADOR AUTOMÁTICO 2 CABEÇAS



SOLDADURA A 90° E ÂNGULOS VARIÁVEIS (DE 45° A 180° NA CABEÇA MÓVEL DIREITA)

CICLO DE TRABALHO COM PLC

AJUSTE DE TEMPO DE FUSÃO DE ACORDO COM PERFIS EXISTENTES NO MERCADO

AQUECIMENTO DA PLACA UNIFORME POR SERPENTINA

DESLOCAÇÃO DA CABEÇA EM GUIAS TEMPERADAS E CROMADAS

ROLAMENTOS CILÍNDRICO DE ESFERAS

POSICIONAMENTO DE PRECISÃO

COMANDOS NOS DOIS PAINÉIS - SISTEMA DE TROCA RÁPIDA DO TEFLON

LINK 45

€ 24.800

profteQ
made in Italy evolution on pvc windows



LINHA PROMOVER

FRT5/CORNERLAB20

profteQ
made in Italy evolution on pvc windows

€ SOB CONSULTA

LINHA AUTOMÁTICA COM SOLDADURA DE 2 CABEÇAS E GRUPO DE LIMPEZA PARA UMA PRODUÇÃO ESTIMADA DE 120 QUADROS POR CADA 8 HORAS DE TRABALHO COM APENAS UM OPERADOR.

MÁQUINAS PARA PVC



**MAQUINA LIMPEZA CANTOS
INCLUI SUPORTE PERFIS KIT03BR
MANGA CORTE AH06A001 E AH00A003**

UN4FA

2 CABEÇAS DE LIMPEZA DE TROCA RÁPIDA
CICLO DE TRABALHO SEMI-ÁUTOMÁTICO
PONTO 0 NO EXTERIOR DO PERFIL
PREPARADO PARA PERFIL COM FOLHA ACRÍLICA

€ 9.250



APARAFUSADORA COM ALIMENTAÇÃO AUTOMÁTICA

BLOQUEIO DE PERFIL E APARAFUSAMENTO COM PEDAL
CARREGAMENTO AUTOMÁTICO DE PARAFUSOS
POSSIBILIDADE DE UTILIZAR VÁRIAS MEDIDAS DE PARAFUSOS
REFORÇOS DE 0.5 A 2.5 MM DE ESPESSURA
AJUSTE DE FORÇA DE APERTO
PREGUIÇAS DE CARREGAMENTO INCLUIDAS
BASE INCLUIDA

AF1

€ 9.450



SERRA SEMI AUTOMÁTICA - COM ESPERAS DIREITA E ESQUERDA INCLUIDAS (KIT16SX E KIT16DX)

SERRA PARA CORTAR BITES PVC
COM ESPERAS DE 1650 MM E 3000 MM



STD16

€ 10.200

ORLADORAS

ORLADORA

E 350 PM

€ 12.850



PRÉ-FRESAGEM

COLAGEM COM COLA POLIURETANO (OPCIONAL)

3 ESPAÇOS LIVRES PARA UNIDADES DE ACABAMENTO

VELOCIDADE DE ALIMENTAÇÃO DE 9MT/MIN

50 MM DE ALTURA DO PAINEL

3 MM DE ESPESSURA DE ORLA EM BOBINE

5 MM DE ESPESSURA DE ORLA EM TIRAS

110 MM DE COMPRIMENTO MÍNIMO DO PAINEL

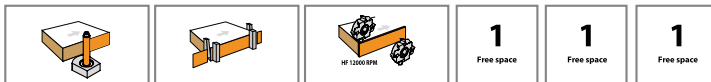

PAINEL TOUCH



ORLADORA CASADEI



ORLADORA COM TUPIAS DE ENTRADA

E 550 PM

€ 18.780

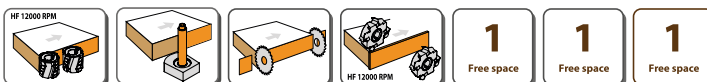

ORLADORA COM TUPIAS DE ENTRADA E GRUPO ARREDONDADOR

E 550 PMCR

€ 25.690

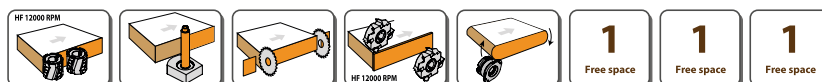

COMPRIMENTO - PM - 3.2 MT
- PMCR 3.7 MT

VELOCIDADE DE ALIMENTAÇÃO - 9 M / MIN
ESPESSURA DO PAINEL MÍN. 8 - MÁX. 50 MM

COMPRIMENTO MÍNIMO PAINEL - 110 MM
LARGURA MÍNIMA - 70MM
DIÂMETRO MÁXIMO DO ROLO - 800 MM
1315W DE AQUECIMENTO - 6 CARTUXOS
POTENCIA TOTAL 5KW APROX.

OPCIONAIS DISPONÍVEIS:

LORASB - GRUPO RASPADOR DE BORDO € 1.570

LORSCL - GRUPO RASPADOR DE COLA € 608

LOSPA3 - GRUPO LIMPEZA COM ESCOVA € 608



ESQUADREJADORAS



ESQUADREJADORA PROFESSIONAL



CARRO DESLIZANTE 3200X395 MM
DIMENSÃO DA MESA DE FERRO FUNDIDO 548X896 MM
CORTE PARALELO DA MESA LATERAL 952X830 MM
BARRA DE CORTE PARALELA 50 MM
DISCO Ø400 MM
CORTE MAX 90° 125 MM
CORTE MAX 45° 90 MM
POTÊNCIA DO MOTOR 7.5HP
VELOCIDADE DO DISCO 3000/4000/5000
AJUSTE DE CORTE PARALELO MANUAL
AJUSTE DE INCLINAÇÃO DO DISCO MOTORIZADO
AJUSTE DE SUBIDA E DESCIDA DO DISCO MOTORIZADO

D-400 A2

€ 12.800



O MODELO MAIS AVANÇADO DA SERIE D PROFESSIONAL.
REUNE AS MAIORES NOVIDADES DE TECNOLOGIA DE ALTA GAMA, TENDO UM RESULTADO EXCELENTE NA SUA PRODUÇÃO.
COM A SUBIDA, DESCIDA E INCLINAÇÕES AUTOMÁTICAS, ESTE MODELO TEM TAMBÉM O POSICIONAMENTO DA PARALELA AUTOMÁTICO QUE TRADUZ O CORTE COM ALTA PRECISÃO, CÓMODO E RÁPIDO.

ESQUADREJADORA PROFESSIONAL



CARRO DESLIZANTE 3200X395 MM
DIMENSÃO DA MESA DE FERRO FUNDIDO 548X896 MM
CORTE PARALELO DA MESA LATERAL 952X830 MM
BARRA DE CORTE PARALELA 50 MM
DISCO Ø400 MM
CORTE MAX 90° 125 MM
CORTE MAX 45° 90 MM
POTÊNCIA DO MOTOR 7.5HP
VELOCIDADE DO DISCO 3000/4000/5000
AJUSTE DE CORTE PARALELO MOTORIZADO
AJUSTE DE INCLINAÇÃO DO DISCO MOTORIZADO
AJUSTE DE SUBIDA E DESCIDA DO DISCO MOTORIZADO

OPCIONAL:

MEDIDOR DIGITAL DE
ÂNGULOS DE ESQUADRIA
E INCLINAÇÃO

D-400 A3N

€ 24.900

ASPIRAÇÃO PARA APARAS

ASPIRADOR DE ACOPLAMENTO A ESQUADREJADORAS



POTÊNCIA MOTOR 1.5 HP
 ASPIRAÇÃO 1.300 M3/H
 Ø VENTILADOR 330 MM (METAL)
 Ø SACOS 1 - 500X500 MM
 Ø FILTROS 1 - 500X600
 Ø TOMA DE ASPIRAÇÃO - 120 MM
 NÍVEL SONORO - 85db
 1.600x563x750 MM
 PESO 60 KG

DE-1300

€ 765



POTÊNCIA MOTOR 3 HP
 ASPIRAÇÃO 2.500 M3/H
 Ø VENTILADOR 300 MM (METAL)
 Ø SACOS 1 - 500X850 MM
 Ø FILTROS 1 - 500X850 MM
 Ø TOMA DE ASPIRAÇÃO - 2X100 MM
 NÍVEL SONORO - 85db
 850X560X1.860 MM
 PESO 50 KG

DE-203/1

€ 450

1107026 - MONOFÁSICO

DE-203/3

€ 450

1107028 - TRIFÁSICO



POTÊNCIA MOTOR 3 HP
 ASPIRAÇÃO 3.600 M3/H
 Ø VENTILADOR 300 MM (METAL)
 Ø SACOS 1 - 500X850 MM
 Ø FILTROS 1 - 500X850 MM
 Ø TOMA DE ASPIRAÇÃO - 3X100 MM
 NÍVEL SONORO - 85db
 1.460x720x2.160 MM
 PESO 60 KG

DE-300/1

€ 690

1107022 - MONOFÁSICO

DE-300/3

€ 690

1107014 - TRIFÁSICO



ASPIRAÇÃO PARA APARAS

POTÊNCIA MOTOR 5.5 HP
ASPIRAÇÃO 4.600 M3/H
Ø VENTILADOR 355 MM (METAL)
Ø SACOS 3 - 510X1.200 MM
Ø FILTROS 3 - 510X1.200 MM
Ø TOMA DE ASPIRAÇÃO - 4X100 MM
NÍVEL SONORO - 80db
2.150X600X2.300 MM
PESO 140 KG

DE-550/3

€ 1.090
TRIFÁSICO



POTÊNCIA MOTOR 7.5 HP
ASPIRAÇÃO 5.800 M3/H
Ø VENTILADOR 345 MM (METAL)
Ø SACOS 4 - 5510X1200 MM
Ø FILTROS 4 - 500X850 MM
Ø TOMA DE ASPIRAÇÃO - 3X100 MM
NÍVEL SONORO - 80db
2.700X600X2.300 MM
PESO 160 KG

DE-750/3

€ 1.375
TRIFÁSICO



RENNER

Kompressoren 

 **Fom Industrie**
Aluminium Working Machinery



MEMODERIVA®
MÁQUINAS & EQUIPAMENTOS INDUSTRIAIS

Rua das flores, Carreira d'Água
2400-016 - Leiria - 244 819 060
geral@memoderiva.pt



www.ecofap.pt



www.memoderiva.pt

Revendedor Autorizado

Preços apresentados sem iva.
Os preços e as características técnicas especificadas neste folheto podem ser alteradas sem aviso prévio. Ressalvam-se eventuais erros tipográficos ou de impressão.