

CATÁLOGO

2025/2026



PETER®

PROFESSIONAL EQUIPMENT





PETER®

PROFESSIONAL EQUIPMENT

ÍNDICE



ELEVADORES ELECTRO-HIDRÁULICOS

Pág. 3



MÁQUINAS PARA PNEUS

Pág. 20



MÁQUINAS PARA CALIBRAR RODAS

Pág. 26



MÁQUINAS PARA ALINHAR DIREÇÕES

Pág. 31



FERRAMENTAS

Pág. 34



PRENSAS HIDRÁULICAS

Pág. 36



PORTA-PALETES

Pág. 38



DEPÓSITOS

Pág. 40



SOLDADURA

Pág. 43



MOVIMENTAÇÃO E ELEVAÇÃO DE VIDROS

Pág. 53



ASPIRADORES

Pág. 58



PETER[®]
PROFESSIONAL EQUIPMENT

ELEVADORES ELECTRO-HIDRÁULICOS





ELEVADORES ELECTRO-HIDRÁULICOS

ELEVADOR 1 COLUNA ELECTRO-HIDRÁULICO - 3 TON

Ref: PS091/092

Elevador móvel de 1 coluna. Prático e seguro! Sistema de segurança com trancas electromagnéticas. Motor em alumínio resistente ao sobreaquecimento. Braços de elevação oscilantes de fácil operação e caixa de controlo em ABS.



3 Toneladas



Tempo de elevação:
50 seg.



Alt. Máx. de elevação:
1900mm



Alt. Mín. de elevação:
90mm



220V / 380V



962 kg



2,2 KW

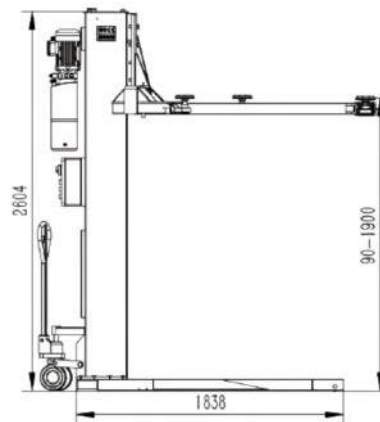
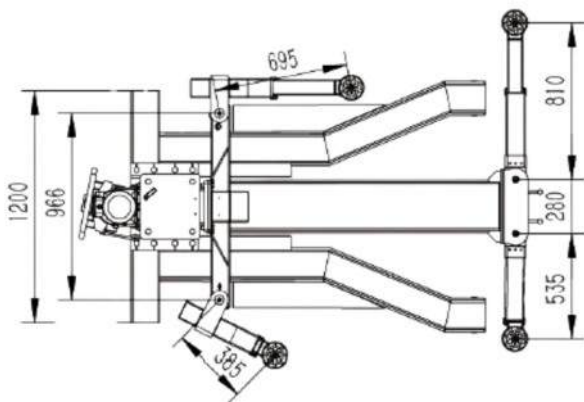

PS092 Monofásico

4.280 €

PS091 Trifásico

4.280 €



PETER[®]
PROFESSIONAL EQUIPMENT

ELEVADORES ELECTRO-HIDRÁULICOS

ELEVADOR 2 COLUMNAS ELECTRO-HIDRÁULICO - 4 TON

Ref: PS103

Robustez e segurança! Elevador com cilindros duplos acionados por corrente hidráulica, sistema de segurança de trancas manuais e travão externo para fácil manutenção. Proteção reforçada dos cabos nas colunas.



4 Toneladas

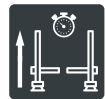

Tempo de elevação
55 seg.



Alt. Máx. de
elevação: 2000mm



Alt. Mín. de
elevação: 110mm



Espaço entre
colunas: 2880mm



220V
(380V disponível)



578 kg



2,2 KW

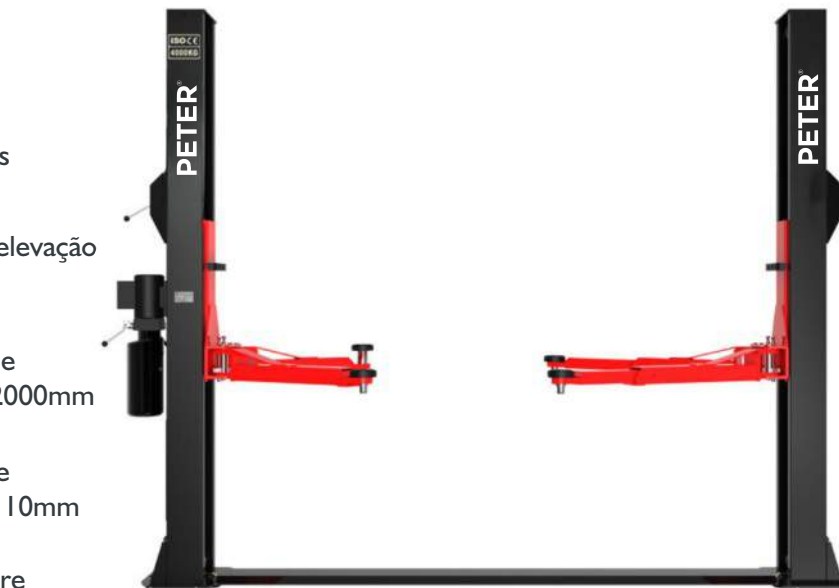

PS232 - KIT
suporte de
rodas

800 €

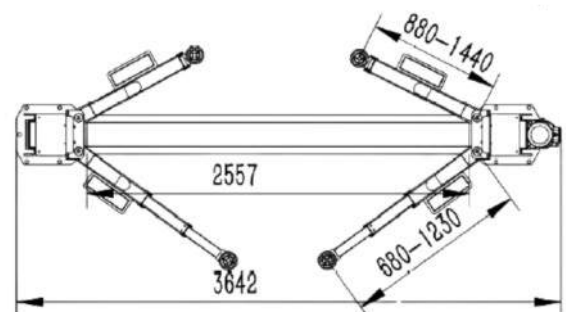
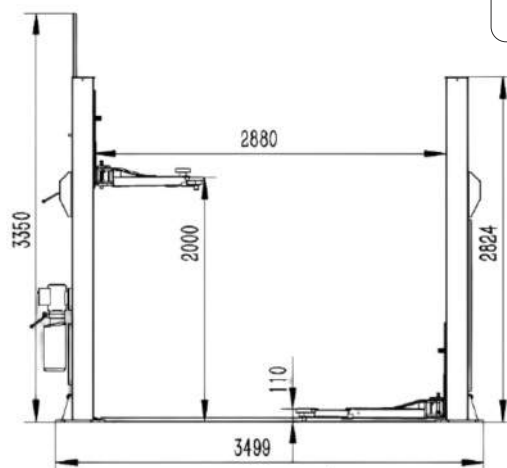

2.095 €



ELEVADORES ELECTRO-HIDRÁULICOS

ELEVADOR 2 COLUMNAS ELECTRO-HIDRÁULICO - 4 TON

Ref: PS101/102

Elevador de 2 columnas electro-hidráulico com capacidade de 4 toneladas. Base reforçada em H. Sistema de segurança com trancas electromagnéticas. Braços assimétricos de 3 estágios. Braços de elevação oscilantes de fácil operação. Inclui 4 peças de 70mm para adaptação de altura. Caixa de controlo robusta.



4 Toneladas



Tempo de elevação:
50 seg.



Alt. Máx. de
elevação: 2010mm



Alt. Mín. de
elevação: 115mm



Espaço entre
columnas: 2880mm



400V ou 220V



630 kg



2,2 KW

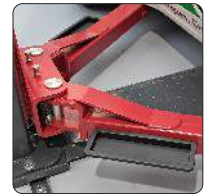

PS232 - KIT
suporte de
rodas

800 €

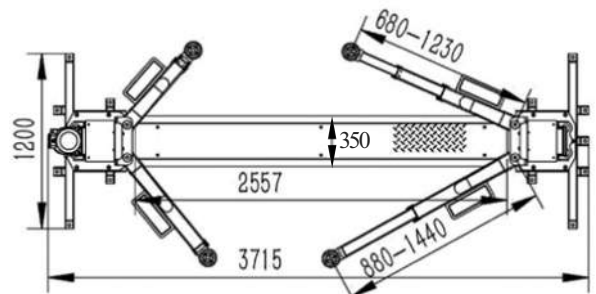
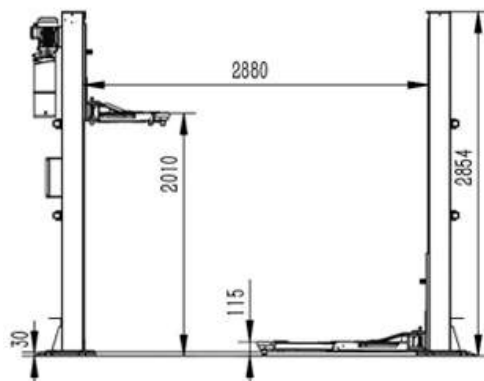

PS101 Trifásico

2.650 €

PS102 Monofásico

2.690 €



PETER[®]
PROFESSIONAL EQUIPMENT

ELEVADORES ELECTRO-HIDRÁULICOS

ELEVADOR 2 COLUMNAS ELECTRO-HIDRÁULICO - 4.5 TON

Ref: PS104

Elevador com base reforçada em H, sistema de segurança com trancas electromagnéticas. Braços assimétricos de 3 estágios. Braços de elevação oscilantes de fácil operação. Inclui 4 peças de 70mm para adaptação de altura.

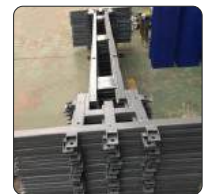

4,5 Toneladas



Tempo de elevação:
55 seg.



Alt. Máx. de
elevação: 2010mm



Alt. Mín. de
elevação: 115mm



Espaço entre
colunas: 2880mm



380V



610 kg



2,2 KW

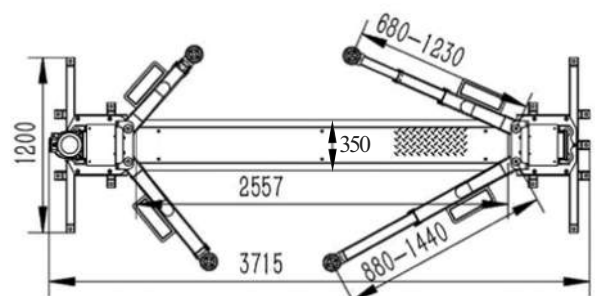
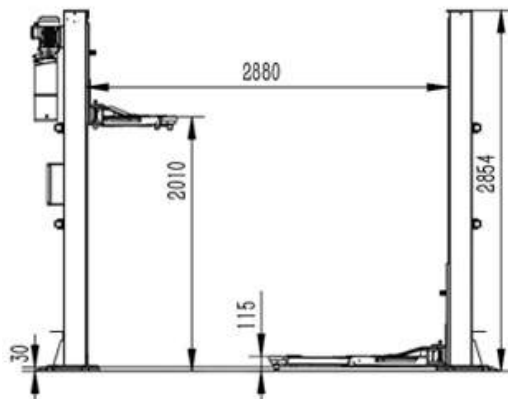

3.490 €



ELEVADORES ELECTRO-HIDRÁULICOS

ELEVADOR 2 COLUMNAS ELECTRO-HIDRÁULICO - 5 TON

Ref: PS105

Elevador de 2 columnas electro-hidráulico con capacidad de 5 toneladas. Base reforçada em H. Sistema de segurança com trancas electromagnéticas. Braços assimétricos de 3 estágios. Braços de elevação oscilantes de fácil operação. Motor em alumínio sem sobreaquecimento. Inclui 3 conjuntos para adaptação de altura a diferentes veículos.



5 Toneladas



Tempo de elevação:
60 seg.



Alt. Máx. de
elevação: 1917mm



Alt. Mín. de
elevação: 117mm



Espaço entre
colunas: 3300mm



380V



900 kg



2,2 KW

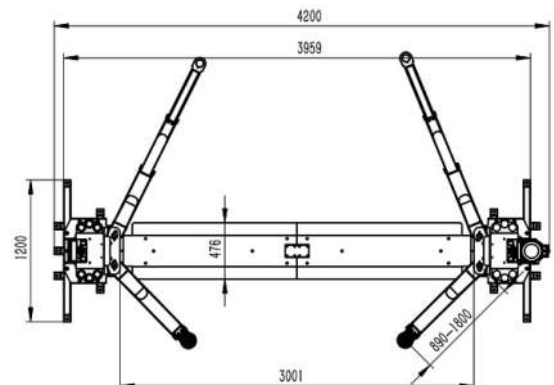
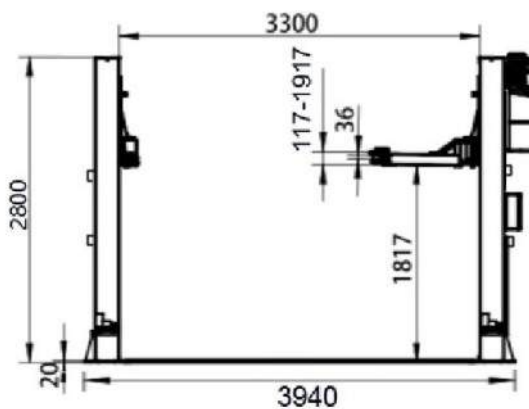
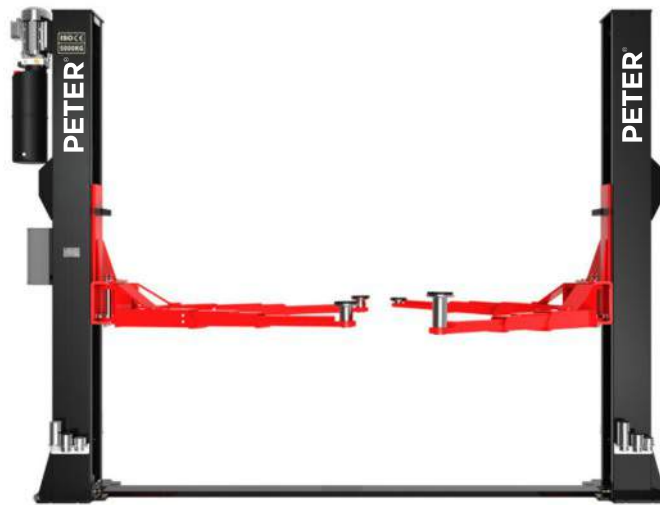

4.400 €



PETER[®]
PROFESSIONAL EQUIPMENT

ELEVADORES ELECTRO-HIDRÁULICOS

ELEVADOR 2 COLUMNAS PARA LAVAGENS - 4 TON

Ref: PS108

Elevador de 2 colunas projetado especialmente para lavagens.
Completamente galvanizado, segurança máxima e motor independente.



4 Toneladas



Tempo de elevação:
50 seg.



Alt. Máx. de
elevação: 2000mm



Alt. Mín. de
elevação: 90mm



Espaço entre
colunas: 2560mm



380V ou 220V



650 kg



2,2 KW

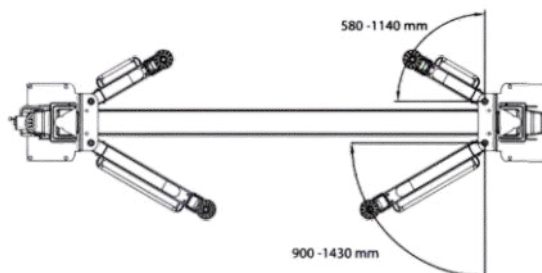
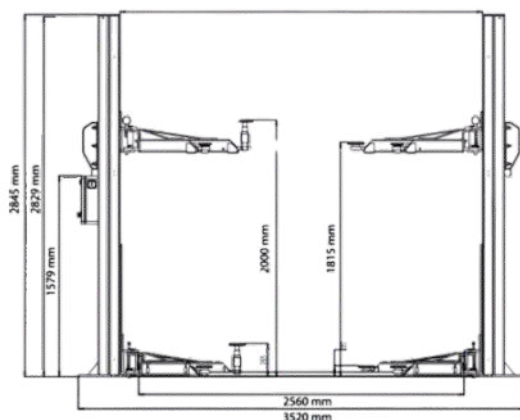
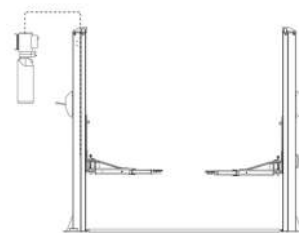

5.350 €



ELEVADORES ELECTRO-HIDRÁULICOS

ELEVADOR 2 COLUMNAS SEM BASE - 4.5 TON

Ref: PS106

Elevador de 2 columnas sem base com sistema de segurança de trancas electromagnéticas. Barra de segurança. braços de elevação oscilantes de 3 estágios. Caixa de controlo ABS. Interruptor de 2 limites padrão.

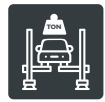

4,5 Toneladas



Tempo de elevação:
55 seg.



Alt. Máx. de
elevação: 2000mm



Alt. Mín. de
elevação: 90mm



Espaço entre
colunas: 2880mm



380V



650 kg



2,2 KW

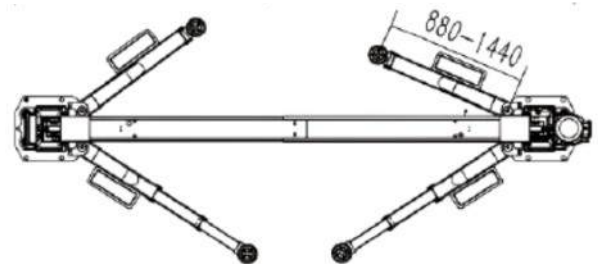
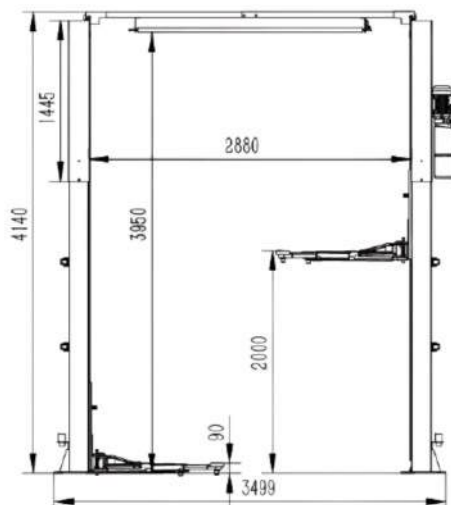
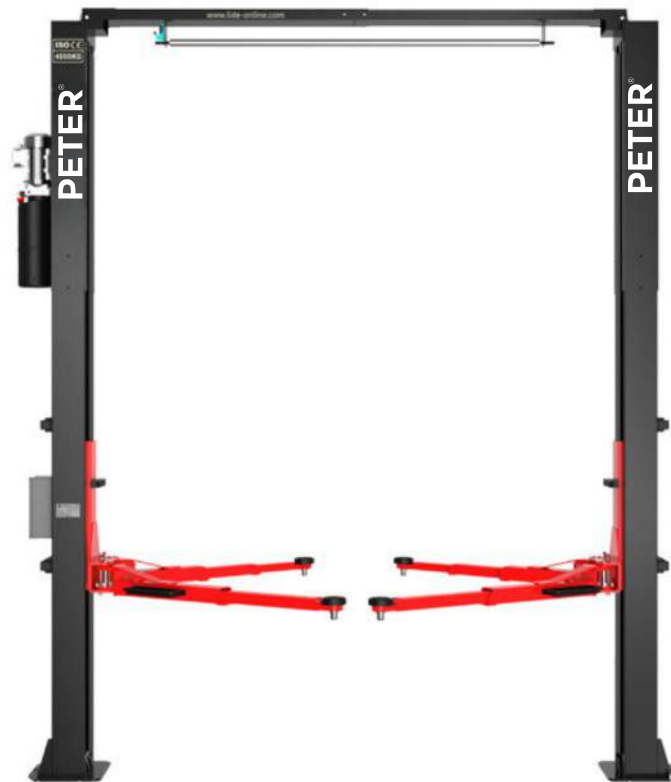

3.540 €



PETER®
PROFESSIONAL EQUIPMENT

ELEVADORES ELECTRO-HIDRÁULICOS

ELEVADOR 2 COLUMNAS SEM BASE - 6.3 TON

Ref: *PS107*

Elevador de duas colunas sem base com sistema de segurança com trancas manuais. Braços assimétricos de 3 estágios. Braços de elevação oscilantes de fácil operação. Inclui 4 peças de 70mm para adaptação de altura.



6,3 Toneladas



Tempo de elevação:
60 seg.



Alt. Máx. de
elevação: 1900mm



Alt. Mín. de
elevação: 116mm



Espaço entre
colunas: 3300mm



380V



1100 kg



3,0 KW

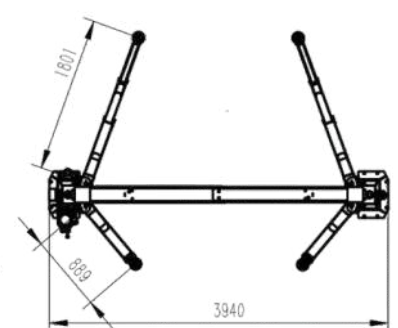
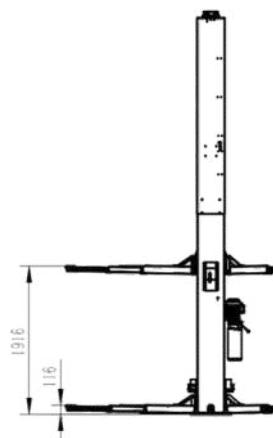
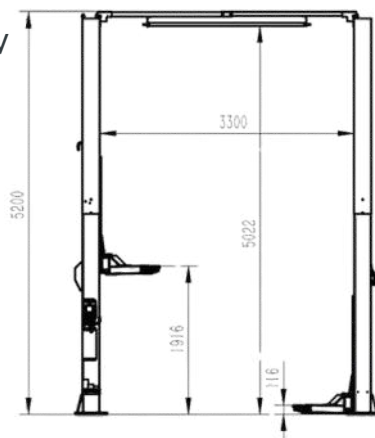

5.490 €



ELEVADORES ELECTRO-HIDRÁULICOS

ELEVADOR 2 COLUMNAS SEM BASE PARA V.E. - 4.5 TON

Ref: PS109

Elevador de 2 columnas electro-hidráulico com capacidade de 4,5 toneladas.
Projectado especialmente para veículos eléctricos.



4.5 Toneladas



Tempo de elevação:
50 seg.



Alt. Máx. de
elevação: 1895mm



Alt. Mín. de
elevação: 100mm



Espaço entre
colunas: 3000mm



380V ou 220V



700 kg



3 KW

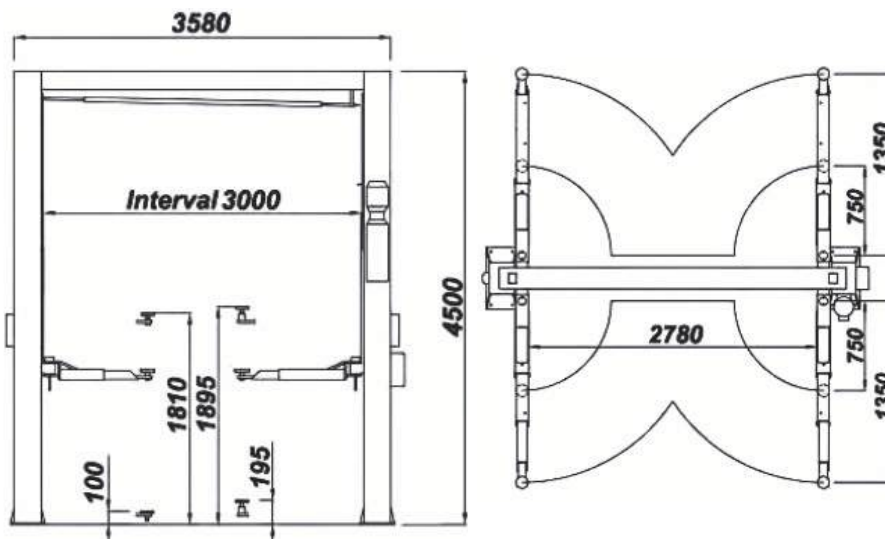

5.450 €



PETER[®]
PROFESSIONAL EQUIPMENT

ELEVADORES ELECTRO-HIDRÁULICOS

ELEVADOR 4 COLUMNAS ALINHAMENTO DE DIREÇÃO - 4 TON

Ref: PS151

Elevador de 4 columnas especial para alinhamento de direcção.
Possuí 2 macacos hidráulicos de 2 Ton cada, sistema de 4 rodas livres. Sistema de segurança electromagnético e manual. Incluí controlador remoto com fio.
Macacos hidráulicos incluídos.



4 Toneladas



Tempo de elevação:
60 seg. + 8seg.



Alt. Máx. de elevação:
1830mm + 450mm



Espaço entre columnas: 2705mm



380V



1745 kg

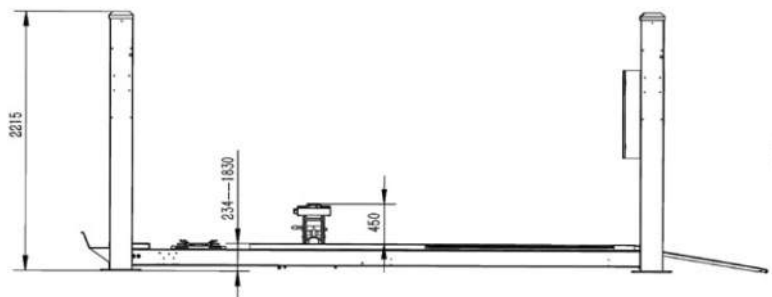
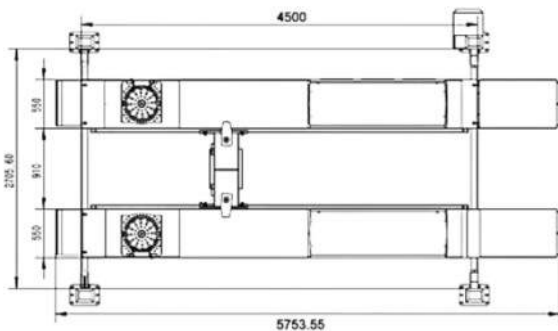

6.290 €



ELEVADORES ELECTRO-HIDRÁULICOS

ELEVADOR 4 COLUMNAS ALINHAMENTO DE DIREÇÃO - 6 TON

Ref: PS152

Elevador de 4 colunas especial para alinhamento de direção. Possui 2 macacos pneumáticos de 2 Ton cada. Sistema de segurança electromagnético e manual. Inclui controlador remoto com fio. Macacos pneumáticos incluídos.

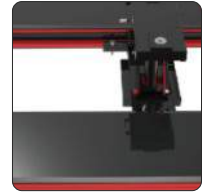

6 Toneladas



Tempo de elevação:
60 seg.



Alt. Máx. de elevação:
1800mm + 529mm

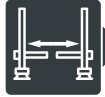

Espaço entre colunas:
3415mm



380V



2636 kg

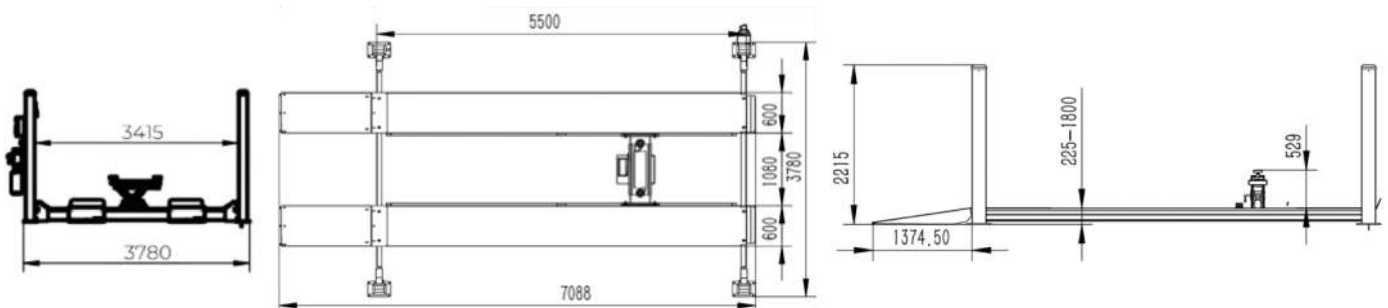

8.990 €



PETER[®]
PROFESSIONAL EQUIPMENT

ELEVADORES ELECTRO-HIDRÁULICOS

ELEVADOR TESOURA DE BAIXO PERFIL - 3 TON

Ref: PS201-3/PS201

Elevador em tesoura de baixo perfil de meia altura para serviços rápidos. Instalação acima do solo. Elevador com mobilidade. Motor em alumínio sem sobreaquecimento. Sistema de segurança de tranças electromagnéticas. «Sistema lifting arm» (eixo de união das 2 tesouras que garantem a sincronização das plataformas.)



3 Toneladas



Tempo de elevação:
40 seg.



Alt. Máx. de elevação:
1000mm



Alt. Mín. de elevação:
105mm



380V ou 220V



600 kg

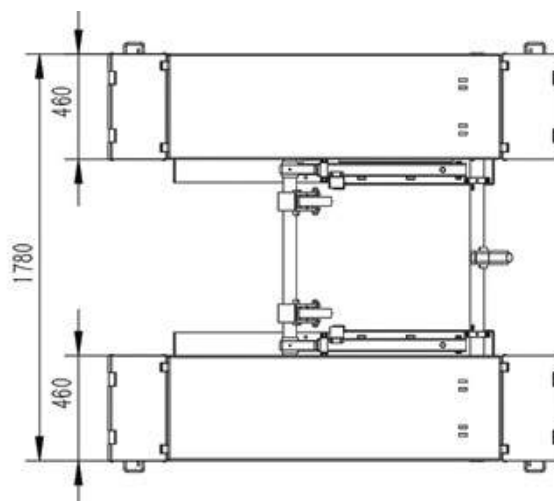
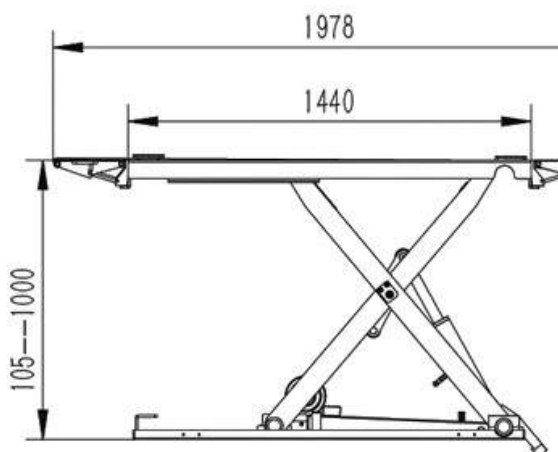

Trifásico: PS201-3

Monofásico: PS201

2.490 €

2.610 €



ELEVADORES ELECTRO-HIDRÁULICOS

ELEVADOR TESOURA BAIXO PERFIL - 3.5 TON

Ref: PS202/PS202-1

Elevador de tesoura de baixo perfil para encastrar com rampas ao pavimento. Motor em alumínio sem sobreaquecimento. Sistema de bloqueio pneumático. 4 cilindros hidráulicos duráveis de alto desempenho. 2 pistons hidráulicos duplos. Sistema de controlo de sincronização fácil. Válvulas hidráulicas especiais.



3,5 Toneladas



Tempo de elevação:
55 seg.



Alt. Máx. de elevação:
1900mm



Alt. Mín. de elevação:
100mm



380V ou 220V



920 kg

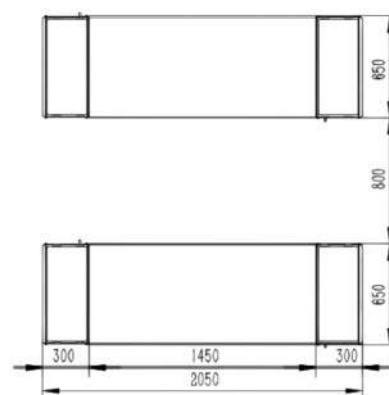
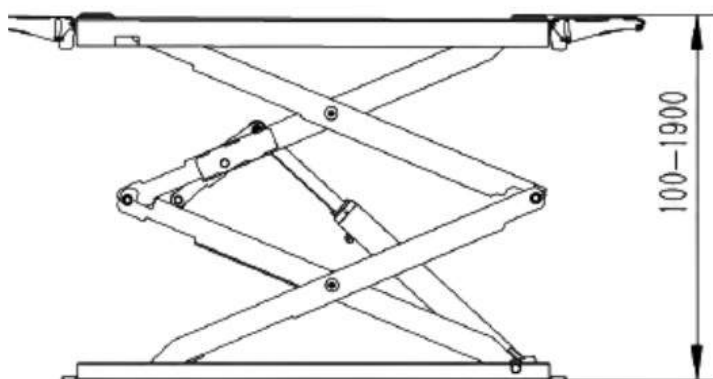

Trifásico: PS202

Monofásico: PS202-1

4.550 €

4.670 €



PETER[®]
PROFESSIONAL EQUIPMENT

ELEVADORES ELECTRO-HIDRÁULICOS

ELEVADOR TESOURA BAIXO PERFIL ALINHAMENTO DE DIREÇÃO - 5.5 TON

Ref: PS203

Elevador de tesoura de baixo perfil com instalação acima do solo ou embutida. Tem incluído macaco central com duplo cilindro e motor em alumínio sem sobreaquecimento. Monitorização do equilíbrio das plataformas (paragem automática). Sistema de segurança pneumático. Plataforma de 750mm (também disponível em 580mm). Traz incluída a caixa de controlo.

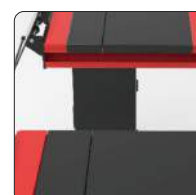

5,5 Toneladas



Tempo de elevação:
70 seg.



ALT. MÁX.
Alt. Máx. de
elevação: 2100mm



ALT. MÍN.
Alt. Mín. de
elevação: 300mm



380V



3250 kg

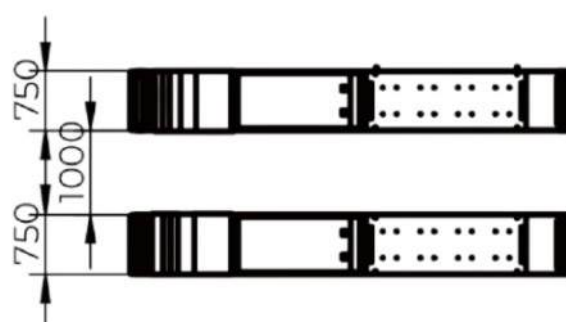
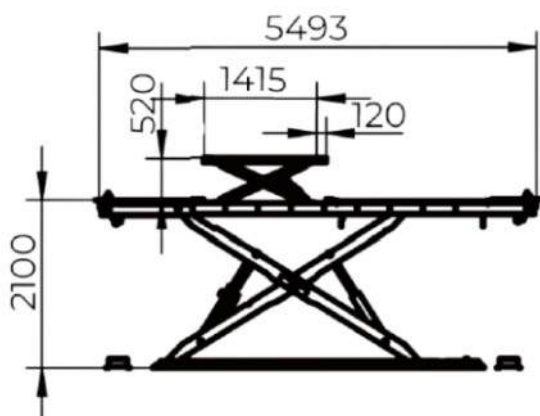

Opcional:
Rampa de 1,8m

860 €

12.500 €



ELEVADORES ELECTRO-HIDRÁULICOS

ELEVADOR PARA MOTOS - 1 TON

Ref: PS221

Elevador eletro-pneumático para motos. Com bloqueio de roda pneumático e calço ajustável para diferentes posições. A placa traseira removível facilita a troca da roda traseira, enquanto o inovador sistema de trava de segurança automática garante estabilidade. Equipado com rampa antiderrapante. Plataforma de 2227,5 mm de comprimento e 890 mm de largura, com um comprimento total de 2878 mm.



1 Tonelada



Tempo de elevação:
20-30 seg.



Alt. Máx. de elevação:
1200mm



Alt. Mín. de elevação: 170mm



1,5 KW



220V



300 kg

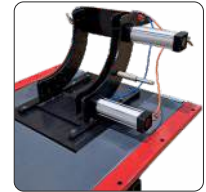

Calço de roda dianteiro amovível e ajustável



Placa posterior amovível



Caixa de controle independente

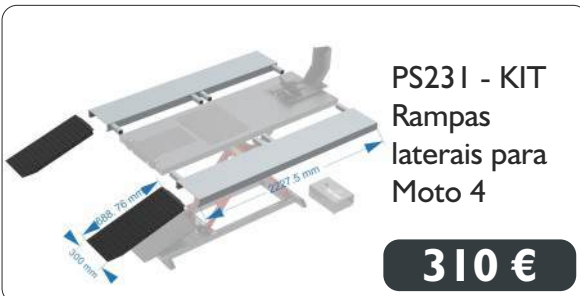

PS231 - KIT Rampas laterais para Moto 4

310 €

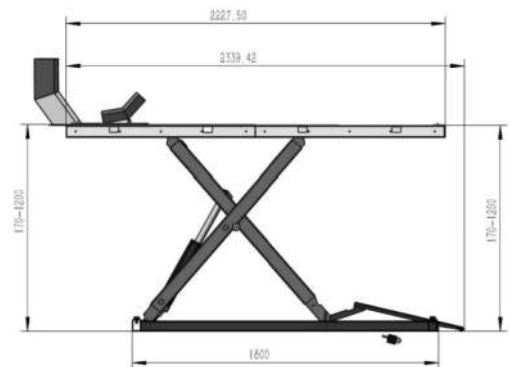
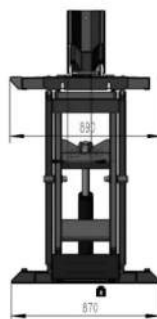

2.170 €



PETER[®]

PROFESSIONAL EQUIPMENT

MÁQUINAS PARA PNEUS





MÁQUINAS PARA PNEUS

MÁQUINA DE DESMONTAR PNEUS AUTOMÁTICA

Ref: PS321



- Máquina com torre pneumática basculante.
- Eixo hexagonal robusto Ø41 mm.
- Bloqueio pneumático simultâneo dos braços horizontal e vertical, com posicionamento automático da cabeça.
- Cabeça com peças plásticas intercambiáveis para proteção da jante.
- Coluna de alta rigidez, estável em todas as posições de trabalho.
- Mesa giratória com rotação nos dois sentidos, acionada por motor elétrico.
- Pedaleira removível para facilitar a manutenção.
- Kit de proteção incluído para sapata, cabeça e mandíbulas.
- Sistema insuflador com canhão de ar / bazuca, para enchimento rápido de pneus.
- Inclui filtro de lubrificação e regulador de pressão.



12-24" Bloqueio exterior



10-22" Bloqueio interior



Diâmetro máximo:
1040mm



Largura da jante:
3-15"



Força do detalonador:
2700kg



Pressão de Trabalho
8 - 10 BAR



380V - 50HZ - 3PH



1 KW



293 kg

Braço auxiliar
DP30 incluído



Facilita a montagem e remoção de pneus de baixo perfil/Runflat. Disco de elevação de pneus. Rolo de posição intermediária.

Pinças autocentradas



Insuflador com canhão de ar



Detalonador



Cabeça em aço com peças de proteção em plástico para evitar danos nas jantes.



Opcional



PS313 - Adaptador para Motociclos/ATV pode diminuir até 5" no tamanho do raio da jante

175 €

Acessórios incluídos



2060 €



PETER®

PROFESSIONAL EQUIPMENT

MÁQUINAS PARA PNEUS

MÁQUINA DE DESMONTAR PNEUS AUTOMÁTICA LEVERLESS Ref: PS324

- Eixo hexagonal Ø41 mm robusto.
- Bloqueio pneumático simultâneo dos braços horizontal e vertical com posicionamento automático da cabeça.
- Cabeça sem alavanca que levanta o talão sem esforço, minimizando o stress no pneu; opção de cabeça tradicional disponível.
- Coluna basculante pneumática com elevada rigidez torsional em todas as posições de trabalho.
- Mesa giratória com rotação nos dois sentidos, acionada por motor elétrico.
- Pedaleira removível para facilitar a manutenção.
- Kit de proteção incluído para sapata do detalonador, cabeça e mandíbulas de aperto.
- Unidade de leitura de pressão com botão de libertação.
- Inclui filtro de lubrificação e regulador de pressão.
- Sistema insuflador com canhão de ar / bazuca, para enchimento rápido de pneus.



12-28"
Bloqueio exterior



10-24" Bloqueio interior



Diâmetro máximo:
1150mm



Largura da jante:
3-15"



Força do detalonador:
2700kg



Pressão de Trabalho
8 - 10 BAR



380V - 50HZ - 3PH



1 KW



336 kg



Braço de apoio auxiliar
esquerdo DP30 incluído:



Facilita a montagem e
remoção de pneus de
baixo perfil e Runflat.
Disco de elevação de
pneus.

Braço de apoio auxiliar
direito PX30 incluído



Facilita a montagem e
remoção de pneus de
baixo perfil e Runflat.
Disco de elevação de
pneus. Rolo de posição
intermediária.

Pinças autocentradas
10" a 28"

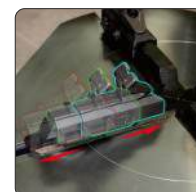

Insuflador com
canhão de ar



Detalonador



Opcional



PS313 - Adaptador
para Motociclos/ATV
pode diminuir até 5"
no tamanho do raio
da jante

175 €

Acessórios incluídos



3.180 €



MÁQUINAS PARA PNEUS

MÁQUINA DE DESMONTAR PNEUS SEMI-AUTOMÁTICA

Ref: PS323



- Braço horizontal oscilante com eixo hexagonal Ø36 mm.
- Bloqueio mecânico e ajuste vertical do braço de montagem.
- Cabeça com inserções plásticas substituíveis para proteção da jante.
- Mandril autocentrante com quatro garras e dois cilindros pneumáticos para fixação segura em todo o tipo de jantes.
- Cilindros de fixação potentes para uma pressão uniforme.
- Mesa giratória com rotação nos dois sentidos, acionada por motor elétrico.
- Pedaleira removível para facilitar a manutenção.
- Pistola de enchimento com manómetro e botão de libertação de pressão.
- Inclui kit de proteção para sapata do detalonador, cabeça e mandíbulas.
- Completa com filtro de lubrificação e regulador de pressão.

Braço horizontal com veio hexagonal de 36mm



Punho de bloqueio do veio hexagonal

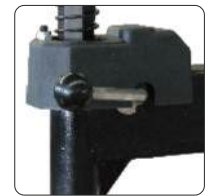

Detalonador



Acessórios incluídos:



- 12-24" Bloqueio exterior
- 10-22" Bloqueio interior
- Diâmetro máximo: 960mm
- Largura da jante: 3-15"
- Força do detalonador: 2700kg
- Pressão de Trabalho 8 - 10 BAR
- 380V - 50HZ - 3PH
- 0.75 KW
- 160 kg



Opcional



PS313 - Adaptador para Motociclos/ATV pode diminuir até 5" no tamanho do raio da jante

175 €

980 €



PETER®
PROFESSIONAL EQUIPMENT

MÁQUINAS PARA PNEUS

MÁQUINA DE DESMONTAR PNEUS SEMI-AUTOMÁTICA ESPECIAL CARROS Ref: PS322



- Braço horizontal oscilante com eixo hexagonal Ø41 mm.
- Torre vertical cilíndrica com elevada rigidez à torção.
- Bloqueio mecânico e ajuste vertical do braço de montagem.
- Cabeça com inserções plásticas substituíveis para proteger a jante.
- Mandril autocentrante de quatro garras com duplo cilindro pneumático para fixação segura.
- Cilindros potentes para uma pressão de fixação uniforme.
- Mesa giratória com rotação em ambos os sentidos, acionada por motor elétrico.
- Pedaleira removível para facilitar a manutenção.
- Unidade de enchimento montada na coluna, com tubo, manómetro e botão de libertação de pressão.
- Kit de proteção incluído para a sapata do detalonador, cabeça de desmontagem e mandíbulas.
- Inclui filtro de lubrificação e regulador de pressão.



12-24" Bloqueio exterior



10-22"
Bloqueio interior



Diâmetro máximo:
1040mm



Largura da jante:
3-15"



Força do detalonador:
2700kg



Pressão de Trabalho
8 - 10 BAR



380V - 50HZ - 3PH



0.75 KW



190 kg

PX10 - Braço
ajudante incluído



O braço PX10 auxilia na desmontagem de pneus de flanco rígido. Esta funcionalidade reduz significativamente o esforço da alavanca e minimiza o risco de danos no talão.

Opcional



PS313 - Adaptador para Motociclos/ATV pode diminuir até 5" no tamanho do raio da jante

175 €

Acessórios incluídos



Pinças
autocentradas

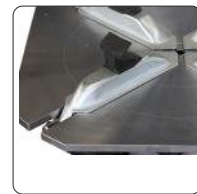

Pedaleira
Removível



Detalonador



Cabeça em aço com
peças de
proteção em plástico
para evitar danos nas
jantes.



1.390 €



MÁQUINAS PARA PNEUS

MÁQUINA DE DESMONTAR PNEUS VEÍCULOS PESADOS SEMI-AUTOMÁTICA ELECTRO-HIDRÁULICA Ref: PS328



- Máquina de desmontar pneus automática, para jantes de furgões, camiões e autocarros com pneu tubeless, drop-centre ou aro cilíndrico com anel.
- Funcionamento eletro-hidráulico para maior binário e força de fixação.
- Consola móvel e comandos simples permitem operação segura e com boa visibilidade.
- Deslizante hidráulico para posicionamento, desmontagem, montagem e detalonagem.
- Grupo hidráulico integrado na máquina para poupar espaço.
- Função stand by reduz o ruído e o consumo de energia.
- Disco de detalonagem móvel montado em casquilhos autolubrificantes.
- Mandril de fixação com rotação em ambos os sentidos.
- Inclui manómetro para controlo da pressão hidráulica.
- Pinças em nylon para proteger as jantes.

Pinças autocentradas



Caixa de controlo 24V + Unidade de controlo móvel



12-26" Bloqueio Exterior



Diâmetro máximo:
1600mm



Peso Máx. da Roda
500kg



Largura máxima
da jante: 780mm



Força do detalonador:
2700kg



Pressão de Trabalho
130 BAR



380V - 50HZ - 3PH



1.5 KW



500 kg



Acessórios incluídos



4.600 €



PETER®

PROFESSIONAL EQUIPMENT

MÁQUINAS PARA PNEUS

MÁQUINA DE DESMONTAR PNEUS VEÍCULOS PESADOS SEMI-AUTOMÁTICA ELECTRO-HIDRÁULICA Ref: PS329



- Motor elétrico robusto e acionamento hidráulico com elevado binário e excelente força de fixação.
- Consola móvel com comandos simples, permitindo ao operador acompanhar o processo com segurança.
- Mandril hidráulico autocentrante universal, com fixação interior ou pelo furo central, para jantes de 14" a 56".
- Carro hidráulico deslizante para posicionamento, desmontagem, montagem e destacagem do pneu.
- Movimento simultâneo do mandril e do braço de ferramentas reduz o tempo de operação.
- Rotação da ferramenta controlada manualmente.
- Mandril com rotação bidirecional e duas velocidades.
- Manómetro integrado para controlo da pressão hidráulica.
- Pinças em nylon para proteger as jantes.

Mandril de extensão



Mandíbulas das pinças



Mandril de fixação autocentrante com controlo hidráulico



Caixa de controlo de 24V



14-46" Bloqueio exterior
56" com adaptador incluído



Diâmetro máximo:
2300mm



Peso Máx. da Roda
1500kg



Largura da jante:
1065mm



Força do detalonador:
2700kg



Pressão de Trabalho
130 BAR



380V - 50HZ - 3PH



1.5 KW



770 kg



Acessórios incluídos



7.600 €

PETER[®]
PROFESSIONAL EQUIPMENT

MÁQUINAS PARA CALIBRAR RODAS





PETER®
PROFESSIONAL EQUIPMENT

MÁQUINAS PARA CALIBRAR RODAS

MÁQUINA DE CALIBRAR RODAS AUTOMÁTICA PARA MOTAS/CARROS Ref: PS301



- Máquina de calibrar rodas automática eletrónica.
- Painel de controlo táctil integrado, de alta visibilidade.
- Introdução automática da distância e diâmetro da roda.
- Arranque automático ao baixar a proteção.
- Travagem automática após a medição.
- Travão de pé para manter a roda parada na colocação dos pesos.
- Fixação rápida da roda com porca de aperto rápido.
- Programas de autocalibração e autodiagnóstico.
- Medição em polegadas ou milímetros.
- Indicação do desequilíbrio em gramas ou onças.
- Programas Alu e programas específicos para motos.
- Modo de otimização para combinar pneu e jante.



Proteção da roda



Projektor LED



Eixo de equilíbrio



Medidor



Ponteiro Laser



Diâmetro máximo:
1000mm



Diâmetro máx. jante:
10"-28"



Peso máx. da Roda:
70kg



Largura máxima da roda:
1.5"-20"



Vel. de rotação:
200 R.P.M.



Precisão de equilíbrio:
+/- 1 grama



220V
50HZ - 1 Fase



0.25 KW



88 kg



O equilibrador inclui modo de equilíbrio dinâmico, equilíbrio estático, 3 equilíbrios ALU e função opt personalizada.



Opcional **PS311**:
Falange universal
5 pernos

410 €



Opcional **PS312**:
Adaptador para motos
com parafuso de fixação

399 €

Acessórios incluídos:



1.080 €



MÁQUINAS PARA CALIBRAR RODAS

MÁQUINA DE CALIBRAR RODAS AUTOMÁTICA PARA MOTAS/CARROS Ref: PS302

- Máquina de calibrar rodas automática eletrónica.
- Painel de controlo com ecrã gráfico LCD retroiluminado e teclas resistentes.
- Introdução automática da distância e diâmetro da roda.
- Arranque automático ao baixar a proteção.
- Travagem automática após a medição.
- Fixação rápida com porca de aperto rápido.
- Programas de autocalibração e autodiagnóstico.
- Medição em polegadas ou milímetros.
- Indicação do desequilíbrio em gramas ou onças.
- Programas Alu e programas específicos para mota.
- Modo de otimização jante/pneu.
- Programa de pesos ocultos.
- Medição automática da largura da jante por sonar.



Medidor



Botões Intuitivos



Ponteiro Laser



Rastreamento Automático



Motor Digital



Eixo de equilíbrio



Medição da jante por Sonar



Diâmetro máximo: 1000mm



Diâmetro máx. jante: 10"-24"



Peso máx. da Roda: 70kg



Largura máxima da roda: 1.5"-16"



Vel. de rotação: 200 R.P.M.



Precisão de equilíbrio: O equilibrador inclui modo de equilíbrio dinâmico, equilíbrio estático, 7 equilíbrios ALU e função opt personalizada.



220V
50HZ - 1 Fase



0.25 KW



90 kg



Opcional **PS311**:
Falange universal
5 pernos

410 €



Opcional **PS312**:
Adaptador para motos
com parafuso de fixação

399 €

Acessórios incluídos:



2.150 €



PETER®
PROFESSIONAL EQUIPMENT

MÁQUINAS PARA CALIBRAR RODAS

MÁQUINA DE CALIBRAR RODAS SUPER AUTOMÁTICA

Ref: PS303



- Máquina de calibrar rodas super automática com funções avançadas de medição e marcação
- Localização, bloqueio e travagem do ponto de fixação bidirecional automáticos.
- Medição automática da largura da jante por sonar.
- Medição automática da largura e distância da jante, sem necessidade de calibração de fábrica.
- Localização ângulo de desequilíbrio com margem de erro inferior a ± 1 gr, com marcador laser.
- Possibilidade de alternar o ponto de aplicação dos pesos e o indicador laser entre as posições das 12h e 6h.
- Iluminação LED circular para melhor visibilidade durante a medição e colocação dos pesos.



Projektor LED

 Diâmetro máximo:
1000mm

 Diâmetro máx.
jante: 10"-32"

 Peso máx. da
Roda: 70kg

 Largura máxima
da roda: 1.5"-25"

 Vel. de rotação:
150 R.P.M.

 Precisão de equilíbrio:
+/- 1 grama

 220V - 50HZ - 1 Fase

 0.25 KW

 115 kg



Ponteiro Laser



Eixo de equilíbrio



Medidor



Medição da jante por Sonar



Opcional **PS311**:
Falange universal
5 pernos

410 €



Opcional **PS312**:
Adaptador para motos
com parafuso de fixação

399 €



O equilibrador inclui todos os modos de medição, incluindo equilíbrio dinâmico, 3 equilíbrios estáticos, 7 equilíbrios ALU e 2 funções ocultas de divisão de contrapesos.

Acessórios incluídos:



2.900 €



MÁQUINAS PARA CALIBRAR RODAS

MÁQUINA DE CALIBRAR RODAS AUTOMÁTICA PARA PESADOS Ref: PS309



- Máquina de calibrar rodas automática para camiões, autocarros e tractores.
- Introdução manual da distância e diâmetro da roda.
- 3 funções ALU e programa de balanceamento estático.
- Travão de pedal para posicionamento preciso dos pesos.
- Seleção de unidades: polegadas/milímetros, gramas/onças.
- Escolha do valor mínimo de desequilíbrio: 5g ou 50g.
- Programas de autocalibração e diagnóstico.
- Plataforma elevatória pneumática para montagem fácil de pneus de grandes dimensões.
- Estrutura reforçada com suporte metálico para maior estabilidade.



Painel de controlo

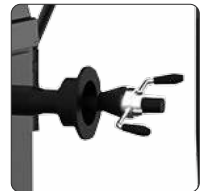

Veio de equilíbrio



Plataforma elevatória



Diâmetro máximo:
1200mm



Diâmetro máx. jante:
10"-26"



Peso máx. da Roda
150kg



Largura máxima da roda:
1.5"-20"



Vel. de rotação:
200 R.P.M.



Precisão de equilíbrio:
+/- 10 gramas



220V - 50HZ - 1 Fase



0.55 KW



210 kg

Acessórios incluídos:



O equilibrador inclui todos os modos de medição, incluindo equilíbrio dinâmico, equilíbrio estático, 3 equilíbrios ALU e função opt personalizada.

2.800 €



PETER[®]
PROFESSIONAL EQUIPMENT

MÁQUINAS PARA ALINHAR DIREÇÕES





MÁQUINAS PARA ALINHAR DIREÇÕES

MÁQUINA DE ALINHAR DIREÇÕES 3D AUTOMÁTICA

Ref: PS341

 **Convergência (Toe)**
Precisão: $\pm 1'$
Alcance: $\pm 24^\circ$

 **245 kg**

 **Câmbor**
Precisão: $\pm 1'$
Alcance: $\pm 10^\circ$

 **Cáster**
Precisão: $\pm 2'$
Alcance: $\pm 20^\circ$

 **Inclinação do eixo de direção**
Precisão: $\pm 2'$
Alcance: $\pm 20^\circ$

 **Desfasamento do eixo**
Precisão: $\pm 1'$
Alcance: $\pm 10^\circ$

 **Alinhamento do eixo traseiro**
Precisão: $\pm 1'$
Alcance: $\pm 10^\circ$



Grampos

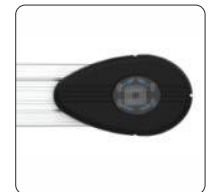

Câmara



Cobertura



Ecrã LCD 32"

- Rastreamento automático de alvos com ecrã único
- Poste e feixe de seguimento automático
- Mini PC e ecrã de 32"
- 4 braçadeiras de roda 10"~22"
- 4 placas de tarja e 2 placas de viragem
- 1 suporte do volante e 1 depressor de travões
- 2 blocos de cunha de borracha

 Câmara HD industrial

 CPU poderoso

 Mini placa de alvo

 Base de dados com mais de 20.000 modelos de automóveis Com actualizações constantes

 Função de adaptabilidade ambiental específica e flash de luz para câmaras

 Aplicável a veículos com grande distância entre eixos

 Câmara substituível

 Múltiplas formas de compensação ou compensação livre

 Não necessita de calibração durante a instalação

 Função de autodiagnóstico e correção

 Função de gestão da eficiência de trabalho

 Sistema operativo Windows

 Registro do estado de operação

 Função dupla de exibição de dados

 Medição completa dos dados do chassis incluindo a distância entre eixos, largura, desalinhamento do eixo, etc

 220V - 50HZ - 1 Fase

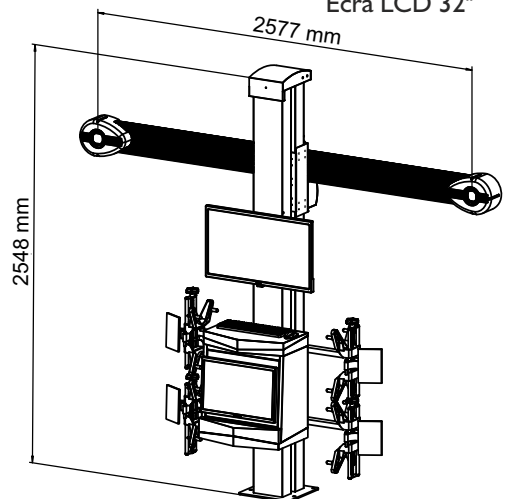

10.900 €

PETER[®]
PROFESSIONAL EQUIPMENT

FERRAMENTAS





CARRO DE FERRAMENTAS 172 PEÇAS E 7 GAVETAS

Ref: PS701

Composto por **172 peças - 7 gavetas**

Módulos de espuma

Fechadura de segurança

Armário em plástico antiderrapante

Medidas: 459x676x1010mm

Módulo de chaves de caixa com 108 peças

Módulo de chaves combinadas de 6 a 22mm

Jogo de chaves anel 6x7mm a 20x22mm, 27x27mm e 30x32mm

Martelo, maço, alicate extensível, fita métrica, alicate de pressão, alicate de corte, alicate de pontas e 2 alicates de freios.

Jogo de chaves de fenda 3.0x75mm, 3.5x75mm, 4.0x100, 5.5x100, 6.5x150, 8.0x175mm

Jogo de chaves Philips 0x75mm, 1x100mm, 2x38mm, 2x100mm, 2x125mm, 3x150mm, 4x200mm

Jogo de chaves Torx 10x75mm, 15x75mm, 20x100mm, 25x100mm, 27x100mm, 30x125mm, 40x150mm

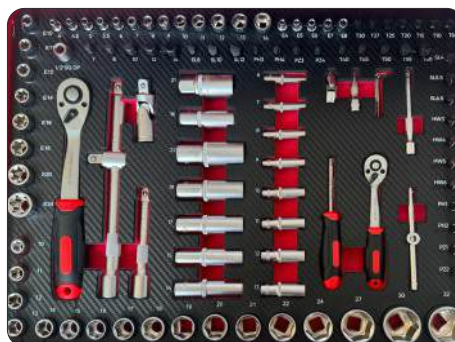
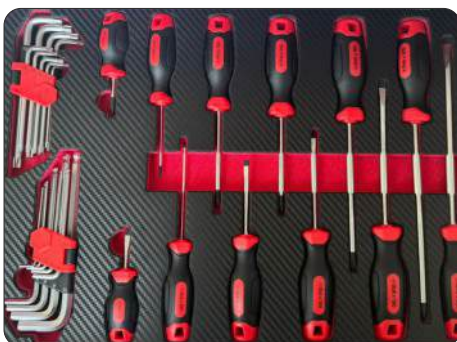

380 €



PETER[®]
PROFESSIONAL EQUIPMENT

PRENSAS HIDRÁULICAS

PETER
PROFESSIONAL EQUIPMENT





PRENSAS HIDRÁULICAS

PRENSA HIDRÁULICA COM PISTÃO MÓVEL

Ref: PS702/PS703

Prensa hidráulica com Pistão Móvel
Válvula de segurança de sobrecarga
Retorno automático do cilindro
Manómetro de pressão
Pistão de aço tratado
Válvula limitadora



Referência	Capacidade	Velocidades	Preço
PS702	25 TON	1	€1.090
PS703	35 TON		€1.210

PRENSA HIDRÁULICA COM PISTÃO MÓVEL

Ref: PS704/PS705

Prensa hidráulica com Pistão Móvel
Válvula de segurança de sobrecarga
Retorno automático do cilindro
Manómetro de pressão
Pistão de aço tratado
Válvula limitadora



Referência	Capacidade	Elevador de Mesa	Velocidades	Preço
PS704	35 TON			€1.499
PS705	50 TON	Sim	2	€2.460



PETER[®]
PROFESSIONAL EQUIPMENT

PORTA-PALETES





PORTA-PALETES 2.5 TON

Ref: PS711



Carga máxima:
2500kg



Altura máx. de elevação:
200mm



Altura da forquilha rebaixada:
85mm



Medidas da forquilha:
1150x540mm



Nível de ruído:
<70 dB



Peso:
57kg



4 rodas poliuretano à frente
1 roda poliuretano dupla atrás

2006/42/CE Diretiva
relativa à segurança
Normas:
ISO 12100:2010
ISO 3691-5:2015/A1:2020

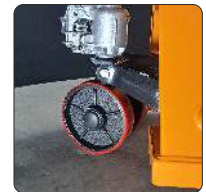

355 €

PORTA-PALETES 2.5 TON

Ref: PS712



Carga máxima:
2500kg



Altura máx. de elevação:
200mm



Altura da forquilha rebaixada:
85mm



Medidas da forquilha:
1150x540mm



Nível de ruído:
<70 dB



Peso:
52kg



Conforms to EN ISO3691-5
Based on Directive 2006/42/EC

ISO 9001
ISO 14001
ISO 45001



2 rodas poliuretano 80x70mm
Roda central em poliuretano

370 €

PETER[®]

PROFESSIONAL EQUIPMENT

SOLDADURA





PETER®

PROFESSIONAL EQUIPMENT

SOLDADURA

INVERTER MMA ARC250

Ref: PS601

Inverter de soldadura para elérodos revestidos

- LED display
- Térmico de proteção
- Faixa de ajuste: 20-250A
- Compatível com elérodos: 6013 e 7018 de 1.6 a 5mm
- Incluí cabo de massa de 1,2m e alicate de 1.8 m



220V - 1 fase



250A



346x142x248mm



Ciclo de trabalho:
250A - 30%
137A - 100%



5,9 kg



Acessórios
incluídos:



225 €

INVERTER TIG PULSADO 3 I5P COM COLD & CLEAN TIG

Ref: PS621

TIG inverter com sistema IGBT

- TIG com Alta Frequência - HF
- MMA
- LED Display
- Faixa de ajuste: 20-250A
- Incluí cabo de massa de 3m e tocha TIG de 4m



220V - 1 fase



Ciclo de trabalho TIG:
250A - 40%
158A - 100%



496x212x
380mm



Ciclo de trabalho MMA:
180A - 40%
114A - 100%



250A



17,3 kg



Acessórios
incluídos:



725 €



INVERTER TIG PULSADO 3 I5P COM COLD & CLEAN TIG

Ref: PS622

TIG inverter com sistema IGBT

- TIG com Alta Frequência - HF
- MMA
- LED Display
- Faixa de ajuste: 20-280A
- Incluí cabo de massa de 3m e tocha TIG de 4m

V 380V - 3 fases

Ciclo de trabalho TIG:
280A - 40%
177A - 100%

496x212x380mm

Ciclo de trabalho MMA:
220A - 40%
139A - 100%

280A

17,3 kg



Acessórios incluídos:



725 €

INVERTER TIG PULSADO 400P COM COLD & CLEAN TIG

Ref: PS623

TIG inverter com sistema IGBT

- TIG com Alta Frequência - HF
- MMA
- LED Display
- Faixa de ajuste: 20-400A
- Incluí cabo de massa de 3m e tocha TIG de 4m

V 380V - 3 fases

Ciclo de trabalho TIG:
400A - 40%
253A - 100%

530x335x465mm

Ciclo de trabalho MMA:
320A - 40%
202A - 100%

400A

23,9 kg



Acessórios incluídos:



1050 €



PETER®

PROFESSIONAL EQUIPMENT

SOLDADURA

INVERTER TIG PULSADO 200P - AC/DC

Ref: PS624

TIG inverter com sistema IGBT

- Pulsado AC/DC
- MMA
- LCD Display
- Faixa de ajuste: 10-200A
- Proteção de tensão e térmica
- Inclui cabo de massa de 3m e tocha TIG de 4m



220V - 1 fase



Ciclo de trabalho TIG:

200A - 30%

110A - 100%



496x212x
380mm



Ciclo de trabalho MMA:

160A - 30%

88A - 100%



200A



16,8 kg



Acessórios
incluídos:



914 €

INVERTER TIG PULSADO 315P - AC/DC

Ref: PS625

TIG inverter com sistema IGBT

- Pulsado AC/DC
- MMA
- LCD Display
- Faixa de ajuste: 10-315A
- Proteção de tensão e térmica
- Inclui cabo de massa de 3m e tocha TIG de 4m



380V - 3 fases



Ciclo de trabalho TIG:

315A - 40%

199A - 100%



490x260x
380mm



Ciclo de trabalho MMA:

315A - 40%

199A - 100%



315A



32,7 kg



Acessórios
incluídos:



2110 €



MULTIPROCESSOS SYNERGIC MIG 160

Ref: PS641

Inverter multiprocessos com tecnologia IGBT

- MIG/MMA/TIG Lift
- Pulsado e duplo pulsado
- Para bobines de 1kg / 5kg de 0.8 ou 1mm
- LED Display
- Faixa de ajuste: 20-160A
- Incluí cabo de massa de 3m e tocha MIG de 3m

V 220V - 1 fase

Ciclo de trabalho MIG:
160A - 40%
101A - 100%

440x180x297mm

Ciclo de trabalho MMA:
160A - 40%
101A - 100%

160A

10,7 kg



Acessórios incluídos:



369 €

MULTIPROCESSOS SYNERGIC CMIG 270 COM CORTE PLASMA

Ref: PS642

Inverter multiprocessos com tecnologia IGBT

- MIG/MMA/TIG Lift/CUT
- Pulsado e duplo pulsado
- Para bobines de 5kg de 0.8 ou 1 mm
- LED Display
- Faixa de ajuste: 20-270A
- Sinérgica

V 220V - 1 fase

Ciclo de trabalho MIG:
160A - 30%
88A - 100%

440x180x297mm

Ciclo de trabalho MMA:
160A - 30%
88A - 100%

270A

Ciclo de trabalho CUT:
40A - 30%
22A - 100%



Acessórios incluídos:



11,9 kg

572 €



PETER[®]
PROFESSIONAL EQUIPMENT

SOLDADURA

MULTIPROCESSOS SYNERGIC MIG-350P DUPLO PULSADO

Ref: PS643

Inverter multiprocessos com tecnologia IGBT
MIG/MMA/TIG Lift

- Proteção térmica
- Controlo totalmente digital
- LCD Display
- Faixa de ajuste da corrente de soldagem: 60-350A

V 380V - 3 fases

946x470x755mm

350A

Ciclo de trabalho MIG:
350A - 40%
221A - 100%

Ciclo de trabalho MMA:
320A - 40%
202A - 100%

41,3 kg



Acessórios incluídos:



1460 €

MULTIPROCESSOS SYNERGIC MIG 500P PARA ALUMÍNIO

Ref: PS644

Inverter multiprocessos com tecnologia IGBT
4 roletes com sistema de arrefecimento a água

- MIG pulsado e duplo pulsado
- Sistema de controlo DSP - 100 posições de memória
- Input - 25 KVA
- Faixa de ajuste: 25-500A
- Fio - 0.8 / 1.0 / 1.2 / 1.6 para bobines de 15 kg
- Incluí carro, cabo de massa de 3m e tocha MIG de 3m

V 380V - 3 fases

725x335x810mm

500A

Ciclo de trabalho MIG:
500A - 60%
387A - 100%

Ciclo de trabalho MMA:
500A - 60%
387A - 100%

80,4 kg



Acessórios incluídos:



5890 €



PLASMA DE CORTE CUT 45 COM COMPRESSOR DE AR

Ref: PS661

Inverter Plasma com compressor de ar incluído

- MMA e Corte até 12mm
- Ecrã LED
- Sem arco piloto, início com contacto
- Incluí tocha 4 mts
- Faixa de ajuste MMA: 20-140A
- Faixa de ajuste CUT: 20-35A

V ▶ 220V - 1 fase

400x220x360mm

KG ▶ 17,9 kg

Ciclo de trabalho CUT:
35A - 30%
19A - 100%

Ciclo de trabalho MMA:
140A - 30%
77A - 100%



Acessórios incluídos:



490 €

PLASMA DE CORTE CUT 50

Ref: PS662

Cortador de plasma

- Ecrã LED e tocha de 4 mts
- 2T/4T - Arranque sem contacto
- Ignição LF/HF arco e arco piloto
- Faixa de ajuste: 20-40A
- Capacidade de corte: até 15mm

V ▶ 220V - 1 fase

410x162x305mm

Ciclo de trabalho CUT:
40A - 30%
22A - 100%

KG ▶ 8,9 kg



Acessórios incluídos:



490 €



PETER[®]
PROFESSIONAL EQUIPMENT

SOLDADURA

PLASMA DE CORTE SYSTEM ENERGY MIER 500H - DSP COMPLETE

Ref: PS645

- Inverter multiprocessos com tecnologia IGBT
- Carro de 4 roletes arrefecido a água
- Cortador de plasma MIG (GMAW)/MMA (SMAW)/TIG Lift
- Inverter MMA e Corte Pulsado e duplo pulso
- Ecrã LED e tocha de 5mts
- 2T/4T Arranque sem contacto
- Sistema de controlo DSP - 100 posições de melo
- Ignição HF arc e arco piloto
- Capacidade de corte: até 50mm
- Faixa de ajuste: 25-500A
- Fio - 0,8 / 1.0 / 1.2 / 1.6
- Inclui cabo de massa de 3m e tocha MIG de 3m



Acessórios incluídos:



	38 kg		380V - 3 fases		Ciclo de trabalho
	720x405x1420mm		500A - 60%		387A - 100%
	480x185x1500A		Ciclo de trabalho MMA:		500A - 40%
	1500A		Ciclo de trabalho MMA:		387A - 60%
	37,6 kg		Ciclo de trabalho CUT:		387A - 100%
					100A - 40%
					77A - 100%



780 €

PLASMA DE CORTE CUT 100

Ref: PS664

- Cortador de plasma industrial para trabalhos pesados
- Adequado para corte manual e automático
- Ecrã LED e tocha de 5 mts
- Ignição de arco HF sem contacto
- Arco de arranque elevado
- Capacidade de corte: até 40mm



Acessórios incluídos:



	380V - 3 fases		Ciclo de trabalho CUT:
	550x280x465mm		100A - 60%
	37,6 kg		77A - 100%



1100 €



PLASMA DE CORTE CUT 120

Ref: PS665

Cortador de plasma industrial para trabalhos pesados

- Adequado para corte manual e automático
- Ecrã LED e tocha 5 mts
- Ignição de arco HF sem contacto
- Arco de arranque elevado
- Sem arco piloto
- Capacidade de corte: 45mm



Acessórios incluídos:



380V - 3 fases



Ciclo de trabalho CUT:

120A - 60%
93A - 100%



690x335x
575mm



44.5 kg



1490 €

PLASMA DE CORTE CUT 200

Ref: PS666

Cortador de plasma industrial para trabalhos pesados

- Adequado para corte manual e automático
- Ecrã LED e tocha 5 mts
- Ignição de arco HF sem contacto
- Arco de arranque elevado
- Sem arco piloto
- Capacidade de corte: 55mm



Acessórios incluídos:



380V - 3 fases



Ciclo de trabalho CUT:

200A - 60%
155A - 100%



700x355x
635mm



75,7 kg



2900 €



PETER[®]
PROFESSIONAL EQUIPMENT

SOLDADURA

TOCHAS DE SOLDAR MIG



Referência	Cabo conector	Comprimento	Corrente máx. de operação	Preço
PS6901	12mm ²	3 m	150 A	€37
PS6902	12mm ²	4 m	150 A	€45



Referência	Cabo conector	Comprimento	Corrente máx. de Operação	Preço
PS6903	18mm ²	3 m	250 A	€60
PS6904	18mm ²	4 m	250 A	€67
PS6905	18mm ²	5m	250 A	€76



Referência	Cabo conector	Comprimento	Corrente máx. de operação	Preço
PS6906	35mm ²	3 m	360 A	€86
PS6907	35mm ²	4 m	360 A	€98
PS6908	35mm ²	5m	360 A	€116



Referência	Arrefecida a água	Comprimento	Preço
PS6909	Sim	4 m	€149

TOCHAS CORTE PLASMA



Referência	Espessura máx. de corte	Comp.	Corrente máx. de operação	Preço
PS6910	18 mm	4 m	60 A	€75



Referência	Espessura máx. de corte	Comp.	Corrente máx. de operação	Preço
PS6920	25 mm	4 m	80 A	€120



Referência	Espessura máx. de corte	Comp.	Corrente máx. de operação	Preço
PS6930	55 mm	5 m	200 A	€380



Referência	Espessura máx. de corte	Comp.	Corrente máx. de operação	Preço
PS6940	12 mm	4 m	40 A	€59

PETER[®]

PROFESSIONAL EQUIPMENT

MOVIMENTAÇÃO E ELEVAÇÃO DE VIDROS

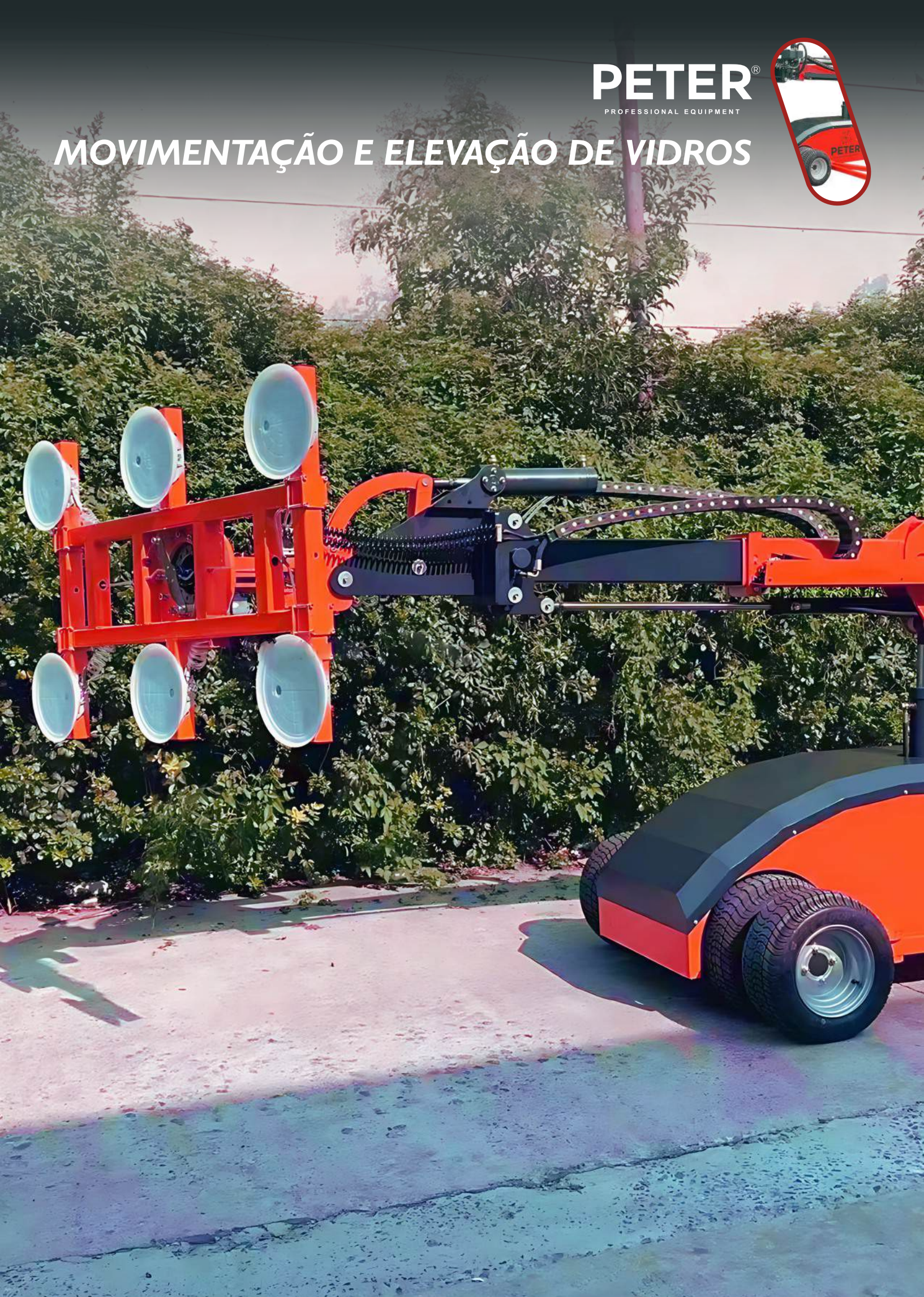



PETER[®]
PROFESSIONAL EQUIPMENT

MOVIMENTAÇÃO E ELEVAÇÃO DE VIDROS

CARRO DE MANUSEAMENTO DE VIDROS

Ref: PS900800

- Carga Máxima: 800kg
- Altura de trabalho: 5000mm
- Ajuste de velocidade: Contínuo
- Bateria: 2x12V / 120ah
- Tipo de travão: Electromagnético
- Peso da máquina: 2080kg
- N° Rodas / Tamanho:
Dianteiras: 2 (Opção: 2+2) / Ø466x195mm
Traseiras: 2 / Ø400x100mm
- Tração: Dianteira
- N° de ventosas / Tamanho: 8 / Ø300mm
- FULL AUTO**
Faixa de rotação 360°
Alcance Giratório 90°
- Motor de tração: 24V / 2500W
- Corrente de carga: 24V / 18A
- Tamanho: 3180x1100x1780mm

O carro de manuseamento de vidros PS900 da marca PETER foi desenvolvido para responder às exigências crescentes da indústria de caixilharias e janelas. Este equipamento foi concebido para oferecer fiabilidade, eficiência e precisão para a montagem de janelas de grande dimensão e elevado peso.

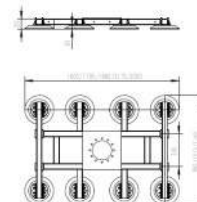
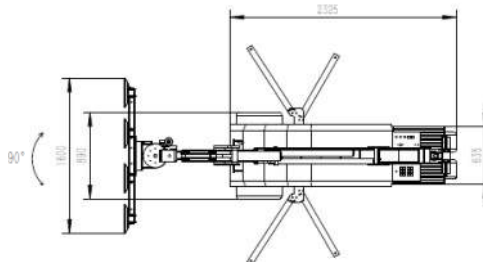
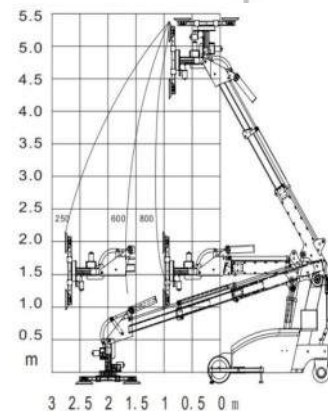
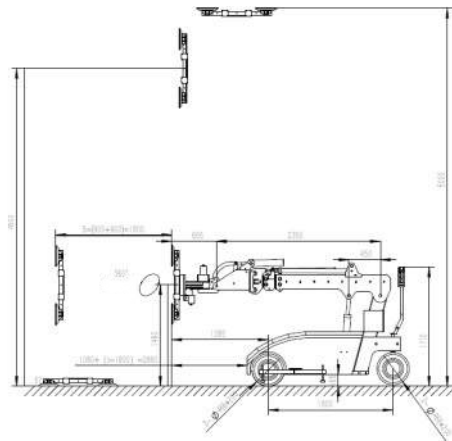

38800 €



PETER[®]
PROFESSIONAL EQUIPMENT

MOVIMENTAÇÃO E ELEVAÇÃO DE VIDROS

ELEVADOR A VÁCUO COM 8 VENTOSAS

Ref: PS500800

O PS500 é uma solução avançada e eficiente concebida para o manuseio, carga e descarga de vidros, vidraças e chapas. Este equipamento versátil é ideal para trabalhar com todo o tipo de superfícies lisas, garantindo segurança, precisão e praticidade em cada operação. desenvolvido para responder às exigências crescentes da indústria de caixilharias e janelas.

 N° de ventosas / Tamanho:
8 / Ø300mm

 Peso da máquina:
100kg

 Rotação:
Manual de 360°

 Tamanho:
1900x1580x200mm

 Inclinação:
Manual de 90°

 Barra de extensão:
500mm

 Corrente de carga:
AC 220V/110V

 Sistema de controlo:
Painel de controlo integrado
Controlo remoto com fios



 Tipo:
DC 12 elétrico

 Carga Máxima:
800kg

4550 €

ELEVADOR A VÁCUO COM 6 VENTOSAS

Ref: PS500600

 Carga Máxima:
600kg

 Tipo:
DC 12 elétrico

 N° de ventosas / Tamanho:
6 / Ø300mm

 Peso da máquina:
90kg

 Rotação:
Manual de 360°

 Tamanho:
2370x1030x200mm

 Inclinação:
Manual de 90°

 Barra de extensão:
500mm

 Corrente de carga:
AC 220V/110V

 Sistema de controlo:
Painel de controlo integrado
Controlo remoto com fios



4100 €



MOVIMENTAÇÃO E ELEVAÇÃO DE VIDROS

ELEVADOR A VÁCUO COM 4 VENTOSAS

Ref: PS500400



Carga Máxima:
400kg



Nº de ventosas / Tamanho:
4 / Ø300mm



Rotação:
Manual de 360°



Sistema de controlo:
Painel de controlo integrado
Controlo remoto com fios



Tipo:
DC 12 elétrico



Tamanho:
870x770x200mm



Peso da máquina:
70kg



Inclinação:
Manual de 90°



Barra de extensão:
500mm



Corrente de carga:
AC 220V/110V



3700 €



PETER[®]
PROFESSIONAL EQUIPMENT

ASPIRADORES





ASPIRADOR WET & DRY - 30 LITROS

Ref: PS401

Função Wet & Dry
Função soprador
Diâmetro do depósito 320mm
Motor arrefecido a ar
Mangueira Flexível: Comprimento 1,5m / Ø Interno 40mm
Comprimento do cabo de alimentação: 4 metros



Potência: 220V-1800W
1 Motor



Depósito de aspiração: 30L



Taxa de fluxo de ar: 53L/S

Acessórios incluídos:

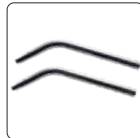

150 €

ASPIRADOR WET & DRY - 70 LITROS

Ref: PS402

Função Wet & Dry
Diâmetro do depósito 420mm
Depósito inclinável para escoar água
Motor arrefecido a ar
Mangueira Flexível: Comprimento 1,5m / Ø Interno 40mm
Comprimento do cabo de alimentação: 4,5 metros



Potência: 220V-2000W
2 Motores



Depósito de aspiração: 70L



Taxa de fluxo de ar: 50L/S

Acessórios incluídos:

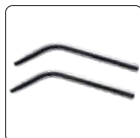

399 €



PETER[®]
PROFESSIONAL EQUIPMENT

ASPIRADORES

ASPIRADOR WET & DRY - 80 LITROS

Ref: PS403

Função Wet & Dry

Diâmetro do depósito 420mm

Depósito inclinável para escoar água

Motor arrefecido a ar

Mangueira Flexível: Comprimento 1,5m / Ø Interno 40mm

Comprimento do cabo de alimentação: 4,5 metros



Potência: 220V-3000W
3 Motores



Depósito de aspiração: 80L



Taxa de fluxo de ar: 108L/S

Acessórios incluídos:



499 €

MÁQUINA DE LAVAR ESTOFOS - 80 LITROS

Ref: PS404

Função Wet & Dry

Diâmetro do depósito 420mm

Motor arrefecido a ar

Mangueira Flexível: Comprimento 1,5m / Ø Interno 40mm



Potência: 220V-2400W
2 Motores



Depósito de aspiração: 80L



Taxa de fluxo de ar: 50L/S

Acessórios incluídos:

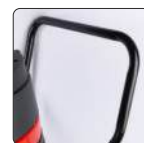
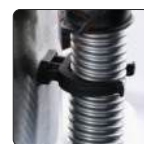

675 €



ASPIRADORES

ESCOVA REDONDA + BOCAL PARA FRESTAS

Ref: PS4270804



- Ø45mm Interno
- Ø50mm Externo
- 240mm comp. Bocal Frestas
- 120mm comp. Escova Redonda

7 €

ESCOVA SÓLIDOS

Ref: PS4270805



- Escova Sólidos
- Ø38mm Interno
- Ø43mm Externo
- 400 mm comprimento

13 €

ESCOVA LÍQUIDOS

Ref: PS4270806



- Escova Líquidos
- Ø38mm Interno
- Ø43mm Externo
- 420 mm comprimento

13 €

JOGO TUBOS

METÁLICOS Ref: PS4270802



- Comprimento: 600mm cada tubo
- Ø37mm Interno
- Ø38mm Externo

17 €

MANGUEIRA FLEXÍVEL

Ref: PS42303



- Para aspiradores PS401
- Comprimento: 1500mm
- Ø40mm Interno
- Ø43mm Externo

13 €

FILTRO COM ARO EM

PLÁSTICO Ref: PS4270803



- Para aspiradores PS402 e PS403

19 €

SACO DE RECOLHA

Ref: PS42302



- 550mm comprimento
- 240mm largura
- Polyester
- Para aspirador PS401

9,90 €

FILTRO DE ASPIRADOR

Ref: PS42301



- Ø160mm
- 160mm de comprimento
- Para aspirador PS401

11,90 €



PETER[®]
PROFESSIONAL EQUIPMENT

NOTAS

A large rectangular area with a red border, containing 20 horizontal dashed lines for writing notes.



PETER®

PROFESSIONAL EQUIPMENT

Preços apresentados sem IVA.
Os preços e as características técnicas especificadas neste
folheto podem ser alteradas sem aviso prévio.
Ressalvam-se eventuais erros tipográficos ou de impressão.

